

Investigation of Dye-Sensitized Solar Cell

Performance with Single Chirality

Semiconducting Carbon Nanotubes

by

Victoria Davis

A Thesis Submitted in Partial Fulfilment of the Requirements for the
Degree of Master of Science in the Materials Science Program in the
Faculty of Science

University of Ontario Institute of Technology

March 2015

© Victoria Davis, 2015

Abstract

This study investigates the performance of dye-sensitized solar cells (DSSCs) assembled with single-walled carbon nanotubes (SWNTs) of a single chirality.

Single-chirality CNTs allow for the adjustment of the Schottky barrier height at the TiO₂/CNT/FTO interface and increases electron diffusion in the photoanode. Furthermore, chirality separated CNTs are expected to absorb less light than mixed chirality CNTs, resulting in better light absorption in the dye and promotion of electron injection into the TiO₂.

Areas of investigation in this study include: DSSC performance comparison between CNT/TiO₂ composites and CNT films, as well as comparison between different chirality-specific and mixed chirality photoanodes. Carbon-based counter-electrode material was also investigated using mixed and chirality-specific films.

Due to their absorption spectra, chiralities (6,5) and (7,3) were chosen and separated by size-exclusion gel chromatography. Characterization of the CNTs and composites included UV-vis-NIR spectroscopy, photoluminescence, XPS and XRD analysis. DSSC characterization includes I-V curves (performed in dark and light) and quantum efficiency. DSSCs demonstrated an improved performance with photoanodes composed of chirality-specific CNT films.

Acknowledgements

First and foremost I would like to offer my sincerest gratitude to my supervisor, Dr. Franco Gaspari, whose encouragement, expertise, and patience has added considerably to my graduate experience. Your guidance and support during my research has been highly valued. Simone Quaranta spent countless hours teaching me how to prepare DSSCs, and listened to me talk (and panic) about my research. He gave me a lot of support and friendship inside and outside of the lab and for that I am truly grateful.

There are many people at UOIT who helped make this project a success. I would like to extend my gratitude to Dr. Liliana Trevani who was always available to provide assistance and answer my many questions. I am sincerely thankful for the advice she gave, as well as generously allowing me to use her equipment and lab space. I would like to thank Dr. Brad Easton for our discussions and for providing resources to help me succeed. I would also like to thank Genevieve Barnes for her generosity. There were many times I needed labware and she was always very kind in lending me equipment. For the SEM and help with Raman spectroscopy, I'd like to thank Ranga Santhanam. I'd also like to thank Dr. Dario Bonetta for allowing me to use his ultracentrifuge.

There are also many from outside of UOIT who were very accommodating and helped me with much needed characterization. I'd like to thank Davit Yeghikyan from UofT for aiding me in the use of their profilometer, as well as Dr. Alex Adronov and Nicole Rice at McMaster University for introducing me to their photoluminescence spectrometer. I would also like to thank the staff at Politecnico di Torino and the Université de Picardie Jules Verne in Amiens for their assistance in characterizing the composites. Additionally, I am extremely grateful to Dr.

Alessandro Latini from La Sapienza Università di Roma for the time and effort he put into the characterization of my DSSCs. He went above and beyond to aid in the completion of this work.

Finally I'd like to thank my parents for all of the support, patience, and encouragement they have given me, as I've pursued my academic goals. Without you, this would not have been possible.

Table of Contents

Abstract	ii
Acknowledgments	iii
Table of Contents	v
List of Tables	ix
List of Figures	x
List of Abbreviations and Physical Constants	xv
1 Introduction	1
1.1 Motivation	1
1.2 Basics of Photovoltaics	3
1.3 The Dye-Sensitized Solar Cell	5
1.3.1 DSSC Structure and Mechanics	5
1.3.2 The Photoanode	8
1.4 Carbon Nanotubes (CNTs)	12
1.4.1 Summary of Common CNT Growth Methods	13
1.4.2 Structure and Electronic Properties of SWCNTs	20
1.4.3 Review of Chirality Separation Methods	23
1.5 Thesis Objective	36
2 Characterization Methods	37
2.1 Optical Spectroscopy Techniques	37
2.1.1 UV-vis-NIR Spectroscopy	38

2.1.2	Photoluminescence Excitation (PLE) Spectroscopy	40
2.1.3	Infrared (IR) Spectroscopy	42
2.1.4	Raman Spectroscopy	43
2.2	Surface Characterization Techniques	47
2.2.1	Scanning Electron Microscopy (SEM)	48
2.1.5	X-Ray Photoelectron Spectroscopy	49
2.1.6	Energy-Dispersive X-Ray Spectroscopy	51
2.3	Other Materials Characterization Techniques	52
2.3.1	Thermogravimetric Analysis (TGA)	52
2.3.2	X-Ray Diffraction	53
2.3.3	Brunauer-Emmett-Teller Analysis (BET)	55
2.4	Photovoltaic Characterization	57
2.4.1	Quantum Efficiency (IPCE)	57
2.4.2	Current-Voltage Measurements (I-V Measurements)	58
3	Experimental	62
3.1	Carbon Nanotube Growth and Preparation	62
3.1.1	Chemical Vapour Deposition of Carbon Nanotubes	62
3.1.2	Preparation of Carbon Nanotubes Grown by Chemical Vapour Deposition (CVD) and High-Pressure Carbon Monoxide (HiPCO)	64
3.1.3	Preparation of an Aqueous Suspension of CNTs	65
3.2	Separation by Chirality: Size-Exclusion Gel Chromatography	66

3.2.1	General Procedure	66
3.2.2	Modified Procedure: Obtain a Single Chirality in a Single Pass	68
3.3	Hydrothermally Synthesized TiO ₂ and TiO ₂ /SWNT Composite	69
3.4	Dye-Sensitized Solar Cell Fabrication and Assembly	70
3.4.1	Cleaning and Treatment of FTO Glasses	70
3.4.2	Preparation of the Photoanode	72
3.4.3	Preparation of Cathode	78
3.4.4	Final Assembly of DSSCs	79
3.5	Characterization Methods	80
3.5.1	Optical Spectroscopy Techniques	80
3.5.2	Surface Characterization	82
3.5.3	Other Materials Characterization Techniques	83
3.5.4	Photovoltaic Analysis	84
4	Carbon Nanotube Preparation and Separation Results	86
4.1	Carbon Nanotubes Grown by Chemical Vapour Deposition And High-Pressure Carbon Monoxide	86
4.1.1	Characterization of CNTs Grown by Chemical Vapour Deposition	86
4.1.2	Characterization of CNTs Grown by High-Pressure Carbon Monoxide	93
4.2	Carbon Nanotube Purification and Separation	97

4.2.1	Separation of Carbon Nanotubes Grown by CVD	98
4.2.2	Separation of Carbon Nanotubes Grown by HiPCO	99
5	Characterization of TiO₂ Composites and SWNT Thin Films	105
5.1	TiO ₂ and CNT/TiO ₂ Composite	105
5.2	SWNT Thin Films	114
6	Dye-Sensitized Solar Cell Performance	117
6.1	Performance of Cells with TiO ₂ , TiO ₂ /SWNT Composite, and SWNT Thin Film	117
6.2	Performance of Cells with Chirality Separated SWNTs	123
6.3	Cathode Performance of SWNT Films (Mixed and Single Chirality)	124
7	Conclusion and Future Work	139
	References	141
	Appendix	150

List of Tables

Table 5-1: Sheet Resistance measurements of chirality-specific films	115
Table 6-1: DSSC performance parameters of devices made with photoanodes containing TiO ₂ /CNT composite, separate CNT and TiO ₂ films, and TiO ₂ alone	117
Table 6-2: DSSC performance parameters of devices composed of chirality specific SWNT films in the photoanode	124
Table 6-3: Surface area of TiO ₂ films and estimated Schottky barrier heights at the FTO/TiO ₂ interfaces influenced by varying chirality films	125
Table 6-4: DSSC performance parameters of devices with the cathode composed of platinum, mixed chirality carbon nanotubes, and (6,5) carbon nanotubes respectively	132

List of Figures

- Figure 1-1:** Record Efficiencies of Different Types of Photovoltaic Cells. From NREL (http://www.nrel.gov/ncpv/images/efficiency_chart.jpg) 2
- Figure 1-2:** a) Energy band diagram of a p-n junction at thermal equilibrium ($V = 0$) b) Energy band diagram of a p-n junction under illumination ($V > 0$) 4
- Figure 1-3:** UV-vis absorption spectrum of N719 in acetonitrile and tert-butanol. Inset is the molecular structure of the N719 dye. (Reproduced with permission from ref [19]) 6
- Figure 1-4:** Schematic of Dye-Sensitized Structure and Mechanics (Reproduced with permission from ref [15]) 7
- Figure 1-5:** Crystal structures of anatase (a), rutile (b), and brookite (c) (Reproduced with permission from ref [20]) 10
- Figure 1-6:** CNT-TiO₂ morphologies: (a) A random mixture of TiO₂ nanoparticles and CNTs, (b) TiO₂ coated CNTs, and (c) CNTs wrapped around TiO₂ nanoparticles. (d) and (e) illustrates how single-walled CNTs may have better inter-phase contact with TiO₂ particles than tubes with multi-walls. (Reproduced with permission from ref [21]) 11
- Figure 1-7:** CNT Growth Mechanisms: Tip Growth (top) and Root Growth (bottom) (Reproduced from ref [26]) 12
- Figure 1-8:** Schematic of Arc-Discharge Setup (Reproduced with permission from ref [29]) 14
- Figure 1-9:** Schematic of Laser Ablation Setup. (Reproduced with from ref [33]) 15
- Figure 1-10:** Schematic of a Basic CVD Setup (Reproduced with permission from ref [26]) 17
- Figure 1-11:** Schematic of a RF-DC Plasma CVD System. (Reproduced with permission from ref [44]) 18
- Figure 1-12:** Diagram of CO flow-tube reactor with water-cooled injector and “showerhead” mixer. (Reproduced with permission from ref [47]) 20
- Figure 1-13:** Graphene sheet showing indexed lattice points (n,m) . \vec{a}_1 and \vec{a}_2 are the unit cell vectors of the two-dimensional lattice and the chiral angle, θ , is defined as the angle between the chiral vector \vec{C} and the zigzag axis. The chiral vector \vec{C} and chiral angle θ define the chirality $(2,4)$ (Reproduced with permission from ref [56]) 22
- Figure 1-14:** Methods to chemically functionalize CNTs: A) Covalent functionalization at defect sites or open ends. B) Covalent sidewall functionalization. C) Noncovalent functionalization with surfactants. D) Noncovalent functionalization by polymer wrapping. E) Endohedral functionalization (Reproduced with permission from ref [62]) 24

Figure 1-15: SWNT sorting using density gradient ultracentrifugation and its corresponding optical absorbance spectra for each fraction. (Reproduced with permission from ref [95])	29
Figure 1-16: Dielectrophoresis of carbon nanotubes. Semiconducting CNTs (white) remain in solution while the metallic CNTs (black) deposit themselves on the electrode array. (Reproduced with permission from ref [101])	31
Figure 1-17: A 2D DNA sheet composed of two hydrogen-bonded anti-parallel ATTTATTTATTT strands wrapped around a (8,4) tube. (Reproduced with permission from ref [68])	32
Figure 1-18: Schematic of a gel chromatography technique using multiple columns (Reproduced with permission from ref [106])	34
Figure 2-1: Density of electronic states for a single nanotube. Solid arrows represent optical absorption and emission transitions while dashed arrows represent nonradiative relaxation. (Reproduced with permission from ref [55])	38
Figure 2-2: PLE Map of mixed SWNTs grown via HiPCO method and dispersed in SDS (Reproduced with permission from ref [55])	40
Figure 2-3: General energy level diagram of Raman and Rayleigh scattering (Adapted from ref [129])	43
Figure 2-4: Raman spectrum of a mixed multi-wall and single-wall carbon nanotubes sample.	44
Figure 2-5: Illustration of the atomic vibrations responsible for the RBM and G bands. (Reproduced from ref [128])	45
Figure 2-6: Schematic of a Scanning Electron Microscope (Reproduced from ref [136])	48
Figure 2-7: Example of an EDS Spectrum of 5.58 at% Au sample. Analysis indicates no detectable impurities since all labeled signals are all due to the presence of gold. (Reproduced with permission from ref [147])	51
Figure 2-8: Schematic of Bragg's Law of Diffraction	53
Figure 2-9: Example I-V Curve labelling the maximum power point (MPP) and its associated voltage and current (V_{mp} , I_{mp}), the open-circuit voltage (V_{oc}), and the short-circuit current (I_{sc}).	59
Figure 3-1: Chemical Vapour Deposition Schematic (top) and Picture (bottom) for the Growth of Carbon Nanotubes	62
Figure 3-2: Schematic of Separation Process	66

Figure 3-3: Photo of Modified Separation Process	67
Figure 3-4: Schematic (top) and Photo (bottom) of an Acetone Vapour Bath in a Double Boiler System	73
Figure 3-5: Modified procedure for anode paste preparation	75
Figure 3-6: Screen-printing mesh to produce TiO ₂ films	76
Figure 3-7: Looking down on the cell from the photoanode side	78
Figure 4-1: SEM images of carbon nanotubes grown by chemical vapour deposition where the catalyst and carbon precursor were mixed in the vapour phase. Deposition was done at 800°C, 150 sccm, with a 3.3 wt.% catalyst	86
Figure 4-2: Raman spectrum of CNTs grown using chemical vapour deposition with the carbon precursor and catalyst mixed in the vapour phase	87
Figure 4-3: TGA of carbon nanotubes grown by CVD	88
Figure 4-4: SEM images of carbon nanotubes grown by chemical vapour deposition where the catalyst and carbon precursor were mixed in the solid phase. Deposition was prepared at 800°C, 150 sccm, and a catalyst of 3.3 wt. %	89
Figure 4-5: Raman Spectroscopy of carbon nanotubes grown by CVD. The precursors were mixed in the solid phase	90
Figure 4-6: TGA of CNTs grown by CVD with precursors mixed in the solid phase	91
Figure 4-7: UV-vis-NIR spectroscopy of CNTs grown by CVD dispersed in 2 wt% SDS solution	92
Figure 4-8: SEM images of carbon nanotubes grown by high pressure carbon monoxide	93
Figure 4-9: Raman Spectrum of carbon nanotubes prepared by high-pressure carbon monoxide	94
Figure 4-10: Thermogravimetric analysis of HiPCO prepared carbon nanotubes	95
Figure 4-11: UV-vis-NIR spectroscopy of dispersed HiPCO carbon nanotubes in 2 wt% SDS.	96
Figure 4-12: Photo of separated tubes via size-exclusion gel chromatography. Chiralities separated from vials left to right: (7,3)/(6,4); (6,5)/(6,4); (7,5)/(8,3)/(8,4); and (8,6)/(9,4)	97

Figure 4-13: UV-vis-NIR spectrum of 1 mL single column separation of carbon nanotubes grown via chemical vapour deposition	98
Figure 4-14: Optical absorption spectra of the two-step separation of the (7,3) chirality. Absorption spectrum of the 1st column and the absorption spectrum of its second separation.	99
Figure 4-15: UV-vis-NIR spectrum of single-pass separation of (7,3) and (6,4) chiralities	100
Figure 4-16: UV-vis-NIR Spectrum of single-pass separation of (6,5)&(6,4) chiralities. Photoluminescence map of (6,5)&(6,4) chiralities	101
Figure 4-17: UV-vis-NIR Spectrum of single-pass separation of (6,5) chirality. Photoluminescence map of separated (6,5) chirality	102
Figure 5-1: Field Emission Scanning Electron Microscopy (FESEM) images of varying magnifications of TiO ₂ grown using the hydrothermal method.	105
Figure 5-2: Field Emission Scanning Electron Microscopy (FESEM) images with varying magnifications of a CNT/TiO ₂ composite grown using the hydrothermal method.	106
Figure 5-3: Energy Dispersive X-Ray Spectroscopy (EDS) of hydrothermally synthesized TiO ₂ (top) and a CNT/TiO ₂ composite (bottom).	107
Figure 5-4: XPS of TiO ₂ Powder hydrothermally synthesized	108
Figure 5-5: XPS of TiO ₂ /CNT Composite hydrothermally synthesized	109
Figure 5-6: FTIR of hydrothermally synthesized TiO ₂ powder	110
Figure 5-7: FTIR of hydrothermally synthesized CNT/TiO ₂ Composite	111
Figure 5-8: Raman spectra of TiO ₂ and TiO ₂ /CNT composite	111
Figure 5-9: XRD Patterns of TiO ₂ and TiO ₂ /CNT Composite	112
Figure 5-10: Transmittance measurements of chirality-specific films (top) and absorbance spectrum of N-719 dye (Reproduced with permission from Ref [19]) (bottom).	114
Figure 6-1: I-V Curves of DSSCs taken under an irradiance of 1 sun. The DSSC with the photoanode composed of the CNT/TiO ₂ composite had the highest fill factor (FF) however the DSSC that performed with the highest efficiency (η) was assembled with separate CNT and TiO ₂ films.	117
Figure 6-2: Quantum Efficiency (IPCE) performance of the DSSCs with TiO ₂ , CNT/TiO ₂ composite, and CNT Film in the photoanode. Maximum incident photon to charge carrier efficiency for each of the DSSCs occur at 525 nm where the anode with the CNT film performs the best at almost double the photoanode with the CNT composite. The DSSCs with CNTs in the photoanode performed better than the DSSC without.	119

- Figure 6-3:** I-V Curves measured in a dark environment. The composite shows the largest increase in dark current with an increase in voltage. The DSSCs assembled with CNT and TiO₂ layered films and only TiO₂ have relatively comparable dark current behaviour 120
- Figure 6-4:** ln(I)-V Curves of DSSCs in a dark environment. Two junctions are evident in the CNT film curve due to the layering in the composition of the anode 122
- Figure 6-5:** I-V Curves of DSSCs taken under an irradiance of 1 sun. DSSCs assembled with a single-chirality anode had the highest fill factor (FF) and efficiency (η). 124
- Figure 6-6:** I-V Curves measured in a dark environment. The (6,5) & (6,4) chirality film produced the smallest increase in dark current with an increase in voltage due to having the highest shunt resistance. 127
- Figure 6-7:** ln(I)-V Curves of DSSCs in a dark environment. Two junctions are evident in the curves due to the layering composition of the anode. 128
- Figure 6-8:** Quantum Efficiency performance of the DSSCs with mixed and single chirality films in the photoanode. Maximum incident photon to charge carrier efficiency for each of the DSSCs occurs at 515 nm where the anodes composed of single-chirality films perform the best. Films with only two chiralities perform the worst largely due to the loss of conductivity. 129
- Figure 6-9:** I-V Curves of DSSCs taken under an irradiance of 1 sun. The DSSC with the cathode composed of platinum displayed highest fill factor (FF) and performed with the highest efficiency (η). The tail in the (6,5) counter-electrode is due to the high amount of semi-conducting tubes thus making the contact between the film and the FTO less ohmic. The result is the formation of two junctions seen by a change in the slope of the curve. 132
- Figure 6-10:** Quantum Efficiency performance of the DSSCs with platinum, mixed chirality films, and (6,5) CNT films. The maximum absorbance occurred at 515 nm with the mixed chirality counter-electrode device having the highest incident photon to conversion efficiency (IPCE) of 30%. 133
- Figure 6-11:** I-V Curves measured in a dark environment. The (6,5) chirality film shows the largest increase in dark current with an increase in voltage while DSSCs assembled with platinum and mixed chiralities in the counter electrode have relatively comparable dark current behaviour. 135
- Figure 6-12:** ln(I)-V Curves of DSSCs in a dark environment. The cathode composed of the (6,5) chirality film shows a low shunt resistance and a high saturated dark current. 136

Abbreviations and Physical Constants

k_B	Boltzmann constant	$1.381 \times 10^{-23} \text{ m}^2 \text{ kg/s K}$
e	elementary charge	$1.602 \times 10^{-19} \text{ C}$
h	Planck's constant	$6.620 \times 10^{-34} \text{ m}^2 \text{ kg/s}$
N	Avogadro's number	6.02×10^{23}
AC	Alternating current	
a_{c-c}	carbon-carbon bond length	
BET	Bruanauer-Emmett-Teller Analysis	
c	Concentration of absorption	
C_h	Chiral vector	
CB	Conduction band	
CNT	Carbon Nanotube	
VB	Valence band	
CVD	Chemical Vapour Deposition	
d	Diameter of carbon nanotube	
DC	Direct Current	
DGU	Density Gradient Ultracentrifugation	
DOC	Sodium deoxycholate	
DOS	Density of states	
DSSC	Dye-Sensitized Solar Cell	
$E_{binding}$	Binding energy	
E_F	Fermi level	
E_{FC}	quasi-Fermi level for electron distribution in the conduction band	
E_{FV}	quasi-Fermi level for the electron distribution in the valence band	

E_g	Bandgap energy
$E_{kinetic}$	Kinetic energy of the electron
EDS	Energy-dispersive X-ray spectroscopy
FF	Fill Factor
FFF	Field-flow fractionation
FTIR	Fourier transform infrared spectroscopy
FTO	Fluorine doped Tin Oxide
GHG	Greenhouse gases
HEM	High energy mode
HiPCO	High-Pressure Carbon Monoxide
I_o	Intensity of the incident light
I_{dark}	Dark current
I_{MP}	Current at maximum power point
I_{ph}	Photocurrent
I_{sc}	Short-circuit current
I_{shunt}	Shunt current
IPCE	Incident photon-to-current conversion efficiency
IR	Infrared
I-V	Current-voltage
L	Optical path length
m	Ideality factor
MWNT/MWCNT	Multi-walled Carbon Nanotubes
P_{in}	Incident solar power
P_{max}	Maximum power point
PE-CVD	Plasma-Enhanced Chemical Vapour Deposition
PLE	Photoluminescence excitation spectroscopy
PV	Photovoltaic

QE	Quantum efficiency
R_{shunt}	Shunt Resistance
RBM	Radial Breathing Mode
SC	Sodium cholate
SDBS	Sodium dodecyl benzene sulphonate
SDS	Sodium dodecyl sulphate
SEM	Scanning electron microscopy
SWNT/SWCNT	Single-Walled Carbon Nanotubes
TEM	Transmission electron spectroscopy
TGA	Thermogravimetric analysis
UV-vis-NIR	Ultraviolet-visible-near infrared
V_{MP}	Voltage at maximum power point
V_{oc}	Open-circuit voltage
XPS	X-Ray photoelectron spectroscopy
XRD	X-Ray Diffraction
α	Absorption coefficient
γ_0	Tight binding nearest neighbour
η	Charge Collection Efficiency
η_{inj}	Electron injection efficiency from dye to TiO_2
θ	Diffraction angle
ν	Frequency of incident radiation
(a_1, a_2)	Unit vectors of hexagonal lattice
(n, m)	Chiral indices

Chapter 1

Introduction

1.1 Motivation

Since the Industrial revolution of the 18th century, humankind has steadily increased its consumption of fossil fuels and, as a result, has increased the amount of greenhouse gases (GHGs), most notably carbon dioxide, released into our atmosphere. The outcome includes significant changes in climate patterns resulting in extreme weather events at enormous human and financial cost. Furthermore, the world's population is projected to increase by 1 billion over the next 12 years and reach 9.6 billion by 2050.^[1] With emerging markets growing and more people entering the middle class, it is expected that by 2050 world-wide energy use will approximately double, further increasing GHG emissions.^[2]

While energy demand is ever-growing, conventional energy resources are dwindling. The issue is not the amount of oil itself; but the amount of high-quality, easily extractable oil. In 2011, 40 out of 54 oil producing nations had peaked in oil production.^[3] According to the former head of exploration and production at Aramco, the Saudi national oil company, the international community would need to find a new Saudi Arabia every couple of years to compensate for energy demand, estimated annual growth, and expected annual decline in production from the older fields. The stability of both the biosphere and the global economy will depend on the transition from fossil fuels to a cleaner and more sustainable energy source.^[3]

Solar radiation is the single most abundant carbon-neutral energy resource. The amount of energy reaching the surface of the Earth in one hour is equal to approximately 4.3×10^{20} J while the amount of primary energy consumed by humans on the planet in the year 2013 was 5.33×10^{20} J.^[4,5] Clearly solar energy can be part of a viable solution to easing our dependence on fossil fuels.

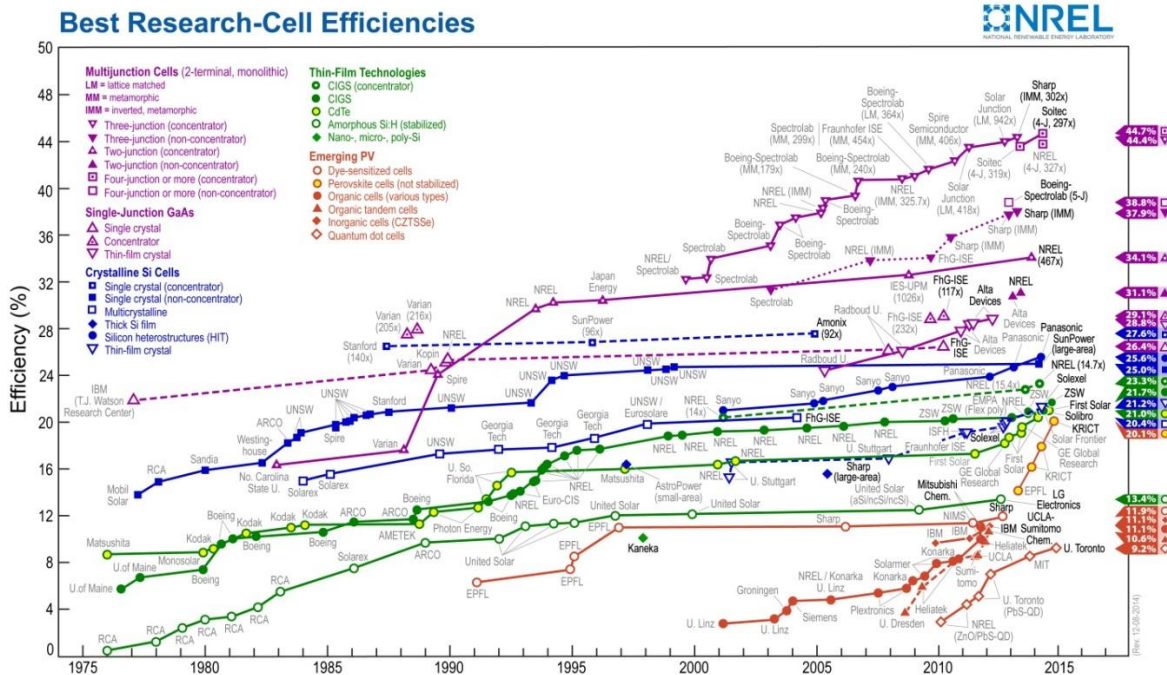

Figure 1-1: Record Efficiencies of Different Types of Photovoltaic Cells. From NREL (http://www.nrel.gov/ncpv/images/efficiency_chart.jpg)

Photovoltaic technology is the fastest growing energy technology with an annual growth rate of approximately 40% in the last two decades.^[6] This rate of growth is due to a combination of decreasing prices and the development of devices with improved efficiency (see Figure 1-1). While the price of conventional solar cells, made from crystalline silicon, has dropped, the main disadvantage to them remains that a high purity of silicon is necessary for these cells to perform

acceptably. . Unfortunately, many of the emerging photovoltaic technologies, while having lower production costs and efficient manufacturing methods, require the use of toxic materials, such as lead or cadmium (in CdTe, or Perovskite cells), and scarce resources such as indium (such as in CIGS cells). In order for photovoltaics to have a significant and sustainable impact on our future energy resources, the industry needs an efficient and cost-effective cell, easily manufactured, and using non-toxic materials. ^[7] The dye-sensitized solar cell (DSSC), which is the focus of this work, fulfills these requirements and could therefore have a future as a contributor to the solar cell industry.

1.2 Basics of Photovoltaics

In simple terms photovoltaic (PV) devices are devices that convert the energy from the sun (photons) into electricity. The Photovoltaic Effect is a phenomenon that describes the generation of an electron-hole pair (collectively known as photocarriers or excitons) by photons that are absorbed into a semiconductor. The key element to a solar cell is the absorber, which has an intrinsic band gap to produce the photocarriers. ^[8]

In the conventional silicon solar cell, two layers are made with one doped with phosphorous and the other doped with boron. Doping the silicon with phosphorous allows “extra” electrons in the structure that are then free to move around (called an n-type layer). On the other hand, doping the other silicon layer with boron allows spaces for electrons to fill, thereby creating holes which also move relatively freely (called a p-type layer). When the n-type and p-type layers are in contact, an electric field forms creating a boundary, or a depletion layer, at the junction (see Figure 1-2 a). The electric field acts like a diode, driving the electrons

to flow from the p-layer to the n-layer. When the device is exposed to sunlight, and therefore an applied bias (see Figure 1-2 b) an electron-hole pair is generated only if the energy of the photon

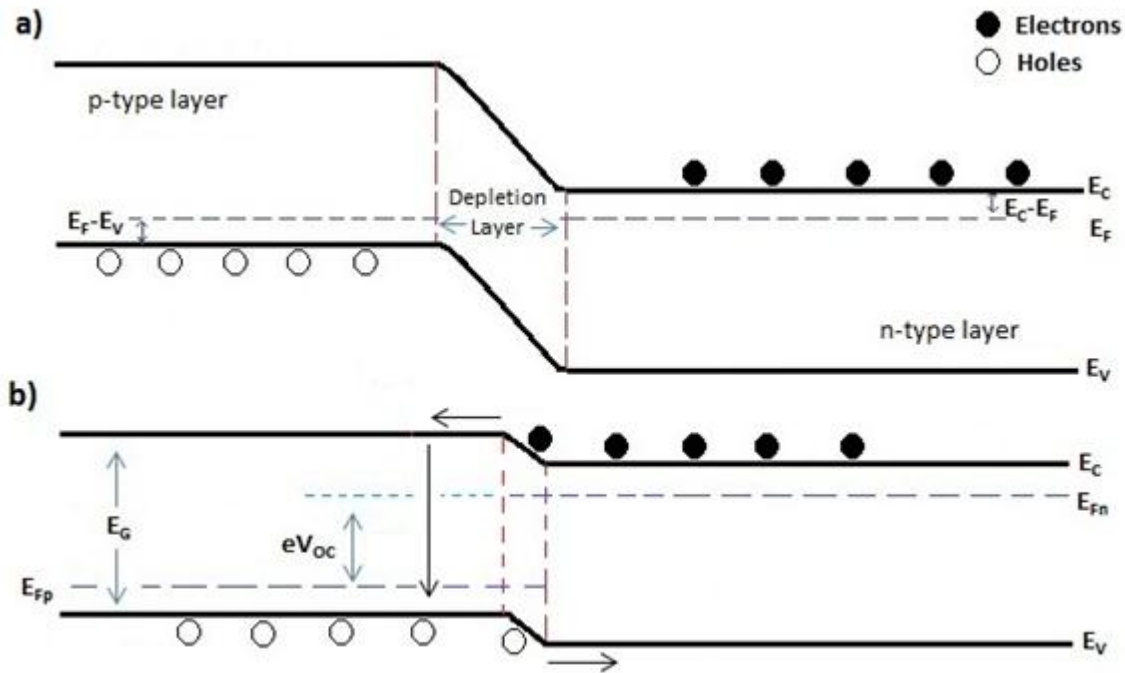

Figure 1-2: **a)** Energy band diagram of a p-n junction at thermal equilibrium ($V = 0$) **b)** Energy band diagram of a p-n junction under illumination ($V > 0$)

is either equal to or greater than the energy of the bandgap (E_G). Absorption occurs and the electron is excited to the conduction band. Due to the applied bias, there is an increase in the energy of the electrons in the n-type layer, while the Fermi energy of the holes remains unchanged. The result is a split in the Fermi energy otherwise known as the quasi Fermi energy of the electrons (E_{Fn}) and holes (E_{Fp}). Separated by the differences in electrochemical potential in the n-doped and p-doped regions, the hole then travels to the junction, while the electron moves through the n-layer and diffuses to the p-type layer before traveling through the external circuit. Excitons that are not removed at the contacts end up recombining causing either the emission of

a photon or heat. The better the junction between the p-n interface can separate the charge, the higher the voltage produced by the cell. The difference in potential between the two contacts is known as the open-circuit voltage and is given by: ^[9]

$$eV_{OC} = E_{Fn} - E_{Fp} \quad (1)$$

where V_{OC} is the open-circuit voltage, e is the elementary charge, E_{Fn} is the quasi-Fermi level for the electron distribution, and E_{Fp} is the quasi-Fermi level for the hole distribution.

In summary photovoltaic devices rely on two important steps to ultimately convert sunlight into electrical energy: the successful absorption of radiation resulting in carrier excitation and the continued separation of the carriers as they travel through the cell.

1.3 The Dye-Sensitized Solar Cell

Dye-sensitized solar cells (or DSSCs) are different from classical p-n junction devices in the way they absorb radiation and separate carriers. Unlike conventional cells, which rely on the p-n junction, DSSCs rely on the dye to absorb the photons and generate carriers. The kinetics of the processes involved are responsible for charge separation. ^[11] The following section discusses the structure of the DSSC and its mechanics in more detail.

1.3.1 DSSC Structure and Mechanics

There are three primary components that make up a DSSC: The working electrode (photoanode), the electrolyte, and the counter electrode (cathode). The working electrode is

conventionally made up of a thin film network of mesoporous titanium dioxide or TiO₂ (approx. 5-15 μm thick) covered with a dye monolayer and supported on conducting glass (in our case FTO glass). After exposure to sunlight, the dye (which is usually a metal-organic Ru-complex) becomes excited by the absorption of a photon.^[12] When excited, the dye injects an electron through its ligands, to the conduction band of the TiO₂ where it then diffuses through the nanostructure TiO₂ medium to the conducting glass. Figure 1-3 shows the absorption spectrum of the N719 dye which has two main absorption peaks located at 540 nm and 380 nm (with 380 nm being outside of the visible spectrum). The excited state has a lifetime of nanoseconds before the dye injects the electron into the conduction band of the TiO₂.^[13] For efficient charge injection, the energy level of the dye would ideally be between 0.2-0.3 V above the TiO₂ conduction band edge. Since the TiO₂ particles are too small for a macroscopic electric field to build, the main transport mechanism through the anode is by diffusion.^[14]

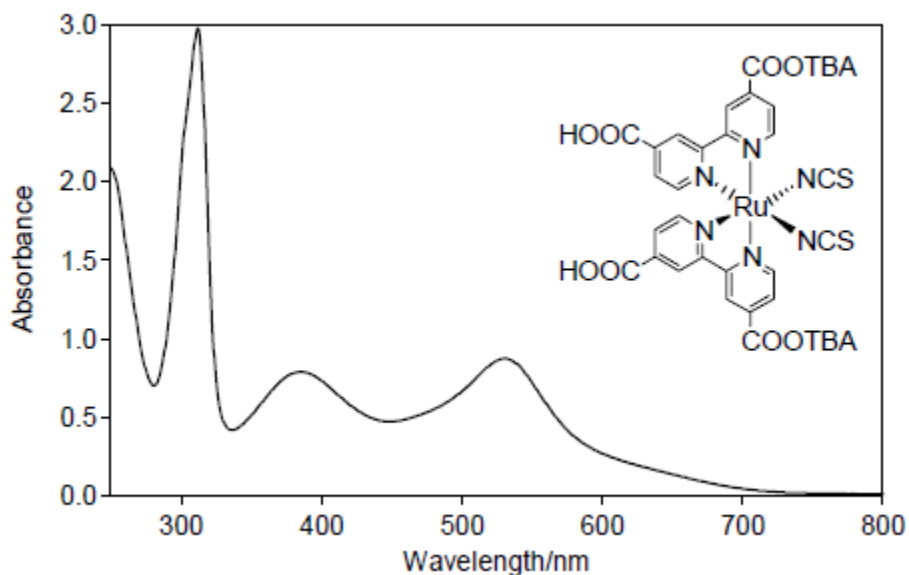

Figure 1-3: UV-vis absorption spectrum of N719 in acetonitrile and tert-butanol. Inset is the molecular structure of the N719 dye. (Reproduced with permission from ref [19])

Figure 1-4 demonstrates the key processes of the DSSC. The main role of the TiO_2 is to separate and allow photogenerated carriers to travel apart from one another. The electron-hole pair will do one of two things: either they will travel to a reaction site, or recombine. The successful transport of the electron through the nanometer-sized particle network is a compelling hurdle in attaining high efficiency since the DSSC's performance significantly depends not only on minimizing carrier recombination; but also promoting the forward travel of the electrons.

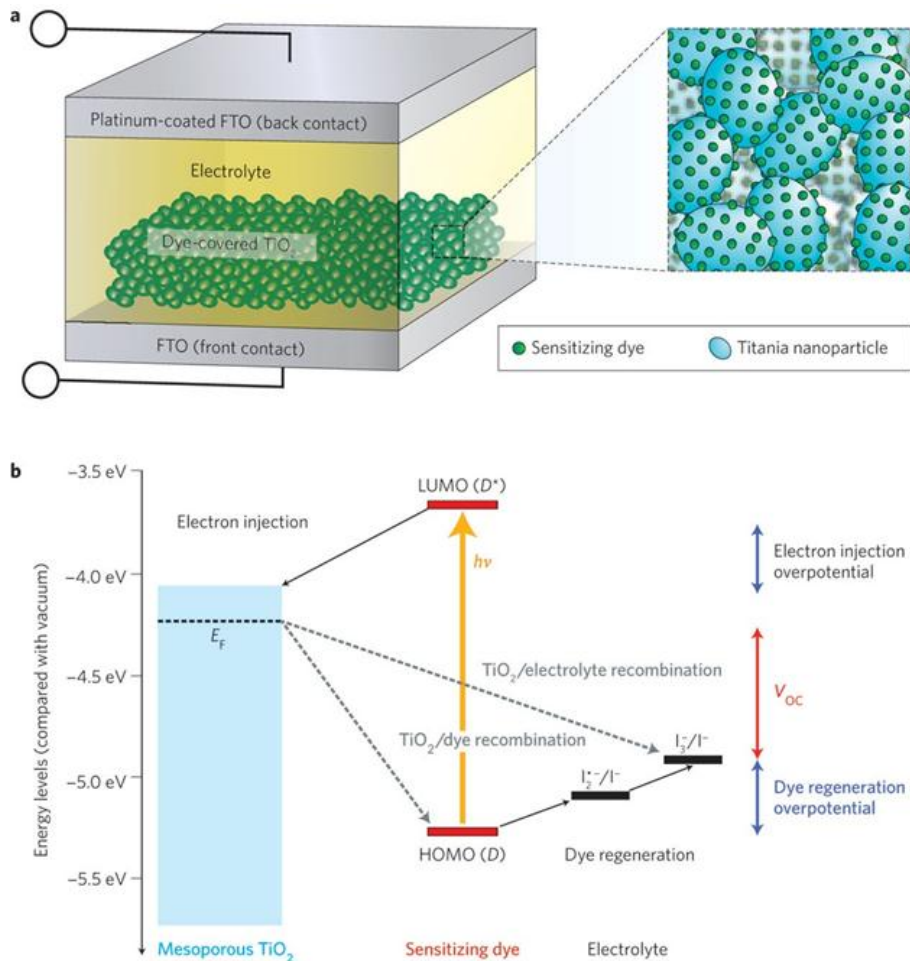

Figure 1-4: Schematic of Dye-Sensitized Structure and Mechanics (Reproduced with permission from ref [15])

Once through the anode the electron flows through the outer circuit to perform electrical work, and returns to the cell via the counter-electrode. At the counter-electrode, the electron is transferred to a hole conducting medium. An iodide/iodine redox couple is used where the reduction is catalyzed by a thin layer of platinum. The reduced species in the electrolyte then diffuse to the oxidized dye and regenerates it in a two-step electron transfer:^[14,16]



One of the driving forces of the DSSC is the potential difference between the quasi-Fermi level and the redox potential of the electrolyte. In order for the electrons travelling through the circuit to be on a favorable path, and not recombine, the forward reaction must be faster than the backward reaction. Therefore, the regeneration of the dye is faster than the recombination of electrons injected into the conduction band of the TiO₂.^[15-18]

There are many processes in the DSSC that can cause a limitation in the device efficiency; however as mentioned previously, a large part of that limitation is found by the slow electron transport and fast electron recombination in the TiO₂ photoanode. The next section is devoted to a closer look at the photoanode and its role in the DSSC.

1.3.2 The Photoanode

The separation and migration of charge carriers is a key process in the photocatalytic reaction of a DSSC. It is in the photoanode, often called the “working electrode”, where this

process takes place. The main component of the anode is a network of nanostructured TiO₂, which serves as a means to separate the carriers by providing a series of pathways for the electron to take when travelling to the conductive glass. The TiO₂ layer is typically made up of spherical anatase particles with diameters in the range of 20-30 nm and a band gap of ~3.2 eV.^[19]

TiO₂ is found in nature in four polymorphs (Figure 1-5), three of which are TiO₂ crystalline phases: anatase (tetragonal), rutile (tetragonal), and brookite (orthorhombic). The three structures differ by the contrast in each octahedral and by the pattern of the octahedral chains. The rutile structure is assembled by octahedrals that are connected by the edges. In anatase, the octahedrals touch only by their vertices, while in the brookite phase, the vertices and edges are connected.^[20] Due to surface free energy and surface stress, anatase is the most thermodynamically stable at small particle sizes (typically of less than 11 nm), brookite being the most stable at sizes between 11 and 35 nm, and rutile is the most stable at larger particle sizes.

In DSSC application, a larger maximum voltage can be obtained from the anatase TiO₂ material because its conduction band is 0.2 V more negative than that of the rutile TiO₂. Therefore in the photoanode the anatase crystal polymorph is preferred over the rutile. This is due to the surface chemistry of the anatase structure; it also allows better electron mobility and has higher conduction-band energy.^[19-21]

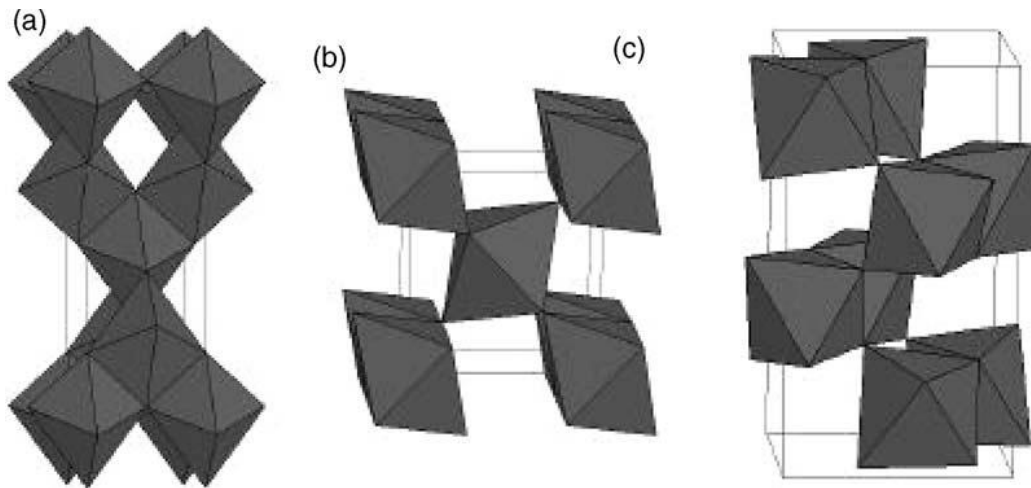

Figure 1-5: Crystal structures of anatase (a), rutile (b), and brookite (c) (Reproduced with permission from ref [20])

The size and density of the TiO₂ nanoparticles can affect the ease of electron journey. The larger the nanoparticle size, the less defects the nanoparticle has and thus fewer electrons are lost to the electrolyte. On the other hand, the larger the nanoparticle is, the less dye it can be coated with (which is disadvantageous since the dye is the source of electrons for the TiO₂). The density of the nanoparticles in the film has a similar effect, where a higher density of nanoparticles yields less surface area to cover with dye; but will provide more paths for the electrons to take to the conductive glass.^[22] However, as photogenerated carrier recombination needs to be prevented to enhance efficiency, focusing solely on optimizing the morphology of the TiO₂ network is not sufficient.

One possible solution to decrease the amount of carrier recombination is to incorporate carbon nanotubes (CNTs) into the working electrode. Due to their exceptional ability to accept electrons, CNTs can facilitate the transport of electrons, and increase the photoconversion efficiency of the DSSC. When put into contact with the TiO₂ network (Figure 1-6), CNTs (which can be insulating, semiconducting, or metallic) could, depending on the electronic structure of a

given CNT, form a Schottky barrier at the TiO_2/CNT interface. TiO_2 is an n-type semiconductor; however, when in contact with a carbon nanotube, electrons from the TiO_2 will move towards the CNT surface, and if the CNT has a lower Fermi level, the CNT may act as an electron sink. This mechanism leaves the TiO_2 behaving similar to a p-type semiconductor as the holes in its valence band travels to the surface.^[21, 25] As stated previously, CNTs come in varying electronic types. If a single bandgap of semiconducting CNTs were to be excluded from the mixture, this would allow the opportunity to “tune” the Schottky barrier height at the CNT/ TiO_2 junction. Tuning the height of the Schottky barrier would not only encourage the electrons to travel in the forward direction (and therefore increase current collection efficiency in the anode) but it might also result in an increased recombination time between carriers.

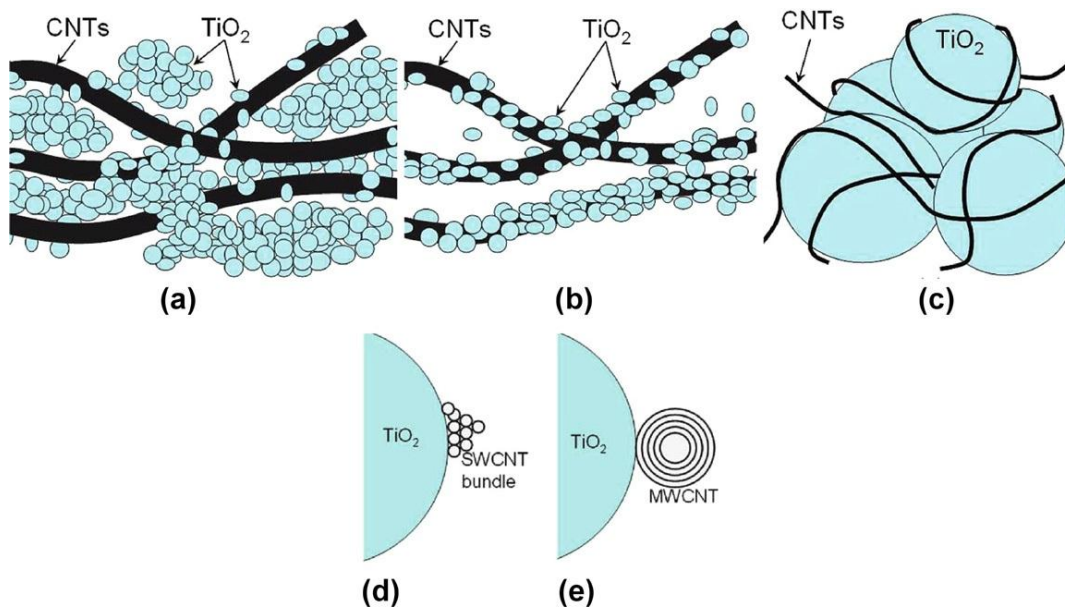

Figure 1-6: CNT- TiO_2 morphologies: (a) A random mixture of TiO_2 nanoparticles and CNTs, (b) TiO_2 coated CNTs, and (c) CNTs wrapped around TiO_2 nanoparticles. (d) and (e) illustrates how single-walled CNTs may have better inter-phase contact with TiO_2 particles than tubes with multi-walls. (Reproduced with permission from ref [21])

1.4 Carbon Nanotubes (CNTs)

Carbon nanotubes (CNTs) are from the fullerene family, which is an allotrope of carbon. Similar to graphite, the chemical bonding of carbon nanotubes is entirely made up of sp^2 bonds; however, the rehybridization of bonds is due to its curvature causing three σ bonds to shift out of plane. On the other hand, the π orbital is delocalized outside the tube making up for the shift. It is due to this rehybridization and the strength of sp^2 bonds that CNTs have remarkable electronic, optical, and mechanical properties. [25] The formation of a single wall carbon nanotube can be visualized as a single graphene sheet rolled into a cylinder. Similarly, a multiwall nanotube has one graphene sheet rolled over another. While this description is used to explain the basic structure of CNTs, this is not the way a nanotube actually forms. CNTs actually “grow” (Figure 1-7) from the substrate either from the tip (tip growth), or from the base (root growth). [26, 27] CNT synthesis and deposition is described in section 1.4.1.

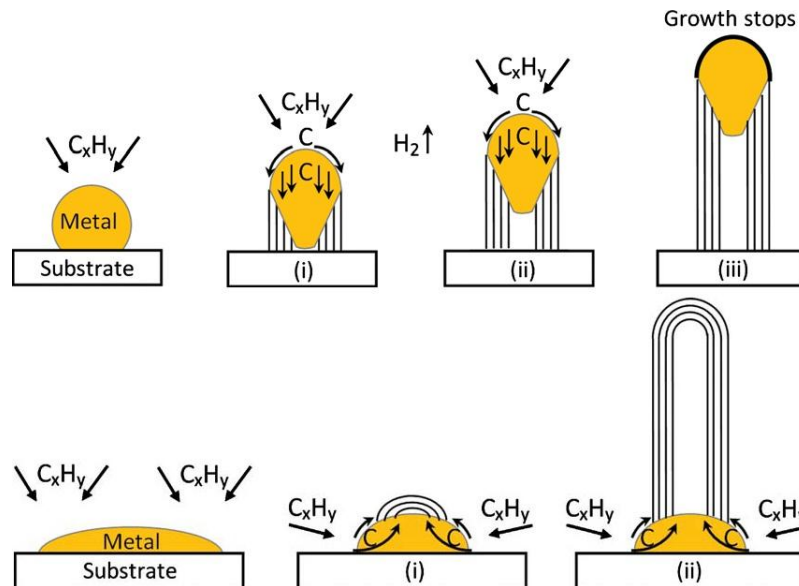

Figure 1-7: CNT Growth Mechanisms: Tip Growth (top) and Root Growth (bottom)

(Reproduced from ref [26])

1.4.1 Summary of Common CNT Growth Methods

The past two decades saw significant research into efficient and high-yield carbon nanotube growth methods.^[27] Conventionally carbon nanotubes can be grown from a carbon source which is either in a pure solid form, or from an organic precursor. The carbon source is broken down in an inert environment

Physical Processes

The processes discussed in this section outline the main physical methods of converting carbon precursors into nanotubes. Due to their immense popularity, they are the most widely used processes for nanotube production.

(i) Arc-Discharge Synthesis

When CNTs were discovered in 1991,^[28] they were observed in the carbon soot on the electrodes from an arc discharge synthesis intended to produce fullerenes. While this technique is considered one of the easiest and most common methods to produce CNTs, it also produces a mixture of soot and catalytic metals which require purification to separate the nanotubes from the crude product. The arc discharge is generated by running a DC current of ~100-200 amps at a low voltage of 20 to 30 V between two high-purity graphite rods electrodes, placed end to end with a space of approximately 1 mm between them. This setup (illustrated in Figure 1-8) is kept in an enclosure with an inert atmosphere typically composed of helium or argon at low pressure. The carbon in the negative electrode sublimates due to the high discharge temperatures. The

electric discharge brings the temperature up to $\sim 6000^{\circ}\text{C}$. During sublimation, the pressure becomes high ejecting carbon atoms from the solid to create plasma between the electrodes. When the atoms travel toward the colder zones, the material accumulates as a small rod-shaped deposit on the counter-electrode. During this process, the electrode is consumed and thus a constant gap between the anode and cathode is kept constant by adjusting the position of the anode. [29-31]

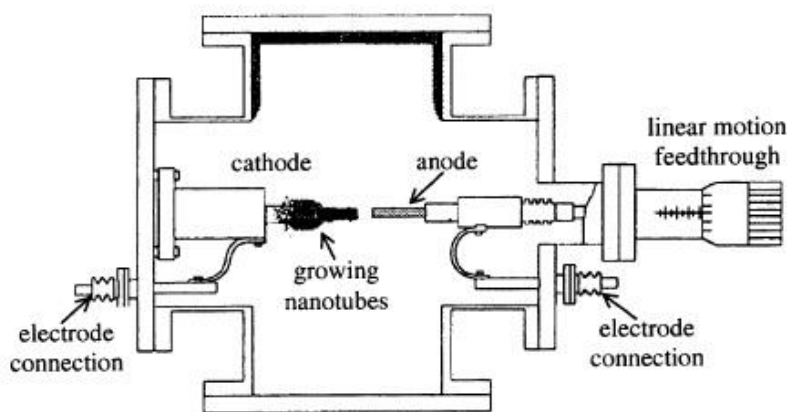

Figure 1-8: Schematic of Arc-Discharge Setup (Reproduced with permission from ref [29])

(ii) *Laser Ablation*

In 1996 Smalley *et al.*^[32] developed a laser ablation technique for the “mass production” of SWNTs. The laser ablation technique is similar to the arc discharge method as it also involves sublimating carbon in a reduced atmosphere resulting in fullerenes or CNTs being produced. The CNTs are prepared by vaporizing graphite rods with a 50:50 catalyst mixture of cobalt and nickel in an inert atmosphere and low pressure. The carbon target is ablated with a focused laser beam of either one of two types: a pulsed laser, or a continuous wave laser. The laser sublimates the

carbon target in a high-temperature chamber resulting in nanotubes developing on the cooler surface as the carbon condenses. This procedure is typically followed by a heat treatment in a vacuum at $\sim 1000^{\circ}\text{C}$ to remove carbon impurities. [33]

In the pulsed laser configuration (Figure 1-9), a ND-YAG laser pulse vaporizes a solid target of graphite or graphite/catalyst into a background gas that is flowing through a quartz tube placed inside a tube furnace. The surface of the target rises to about 6000K while at the end of the pulse the temperature drops to 4000K at which point the composite solid material is converted into a vapour that accumulates when placed in an external furnace that is heated to around 800°C . At this temperature CNTs can grow. On the other hand, in the continuous laser configuration, a continuous CO_2 laser is focused on a graphite target heating it to 3000-3500K. In this configuration the target is placed vertically where the inert gas flows from the bottom of the chamber to the top. [32-34]

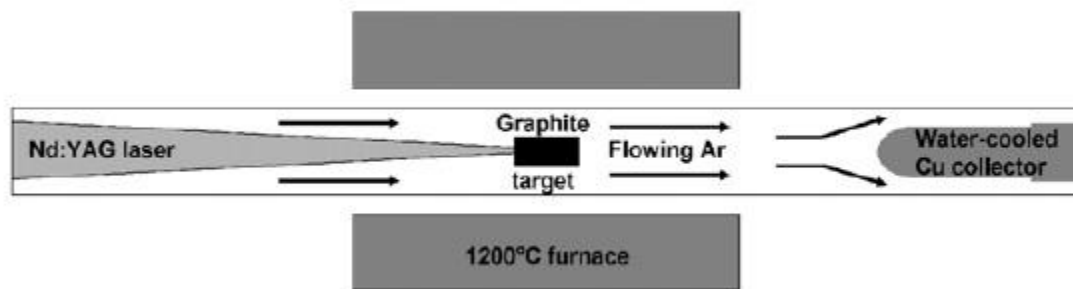

Figure 1-9: Schematic of Laser Ablation Setup. (Reproduced from ref [33])

Improvements were made to the basic technique by Thess *et al.* [35] and Rao *et al.* [36] using a double beam laser producing a higher purity of approximately 90% and a better structure than tubes grown via arc-discharge.

Chemical Processes

Chemical techniques for growing carbon nanotubes have many advantages in comparison to the physical methods discussed previously. The first advantage is that the reaction process and often the reactor design, is simple and easy to control. The raw materials are abundant and readily available while most processes themselves are fairly cost-effective. These processes are capable of growing the CNTs directly onto substrates, possibly eliminating future steps. Vapour deposition techniques make depositing vertically aligned CNTs possible and high-pressure techniques allow for continuous operation to easily scale up the process. However, these processes come with large amounts of metallic and amorphous impurities which require further purification.

(i) Chemical Vapour Deposition

Chemical vapour deposition (otherwise known as thermal chemical vapour deposition) is a technique for growing nanotubes that involves preparing a substrate with a metal catalyst, generally iron, nickel, or cobalt (Figure 1-10). This method first emerged in 1996^[37] as a solution for large-scale production of CNTs. The CVD technique is called a “gas-phase” or “vapour-phase” technique because the carbon source is a hydrocarbon gas that continuously flows through the system. As it flows, it enters a hot zone that is heated by a furnace or IR lamp, where it attaches itself to a substrate and grows to form nanotubes from either the root or the tip. CNTs are formed as a result of decomposition of hydrocarbon gas which deposits itself onto a substrate and grows from a metal catalyst. CVD is conventionally performed at temperatures

ranging from $\sim 700^{\circ}\text{C}$ to 1200°C . However it has been reported that the minimum temperature in which CNTs can grow (using this method) is around 450°C .^[38-40]

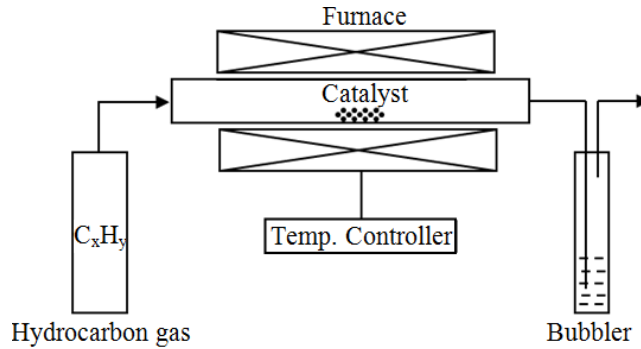

Figure 1-10: Schematic of a Basic CVD Setup (Reproduced from ref [26])

An important aspect to CVD is the type of catalyst used and the substrate prepared. The substrate used defines the nature and type of carbon nanotubes grown. Conventional materials used as a substrate can be silicon, quartz, or even alumina. Similarly, the catalyst used has an effect on the nanotubes' parameters. Catalysts are typically metal or organometallic nanoparticles containing iron, cobalt, or nickel. The particle size of the catalyst is proven to define the diameter of the tube and therefore the deposition technique of the catalyst should be chosen carefully.^[41, 42]

(ii) *Plasma-Enhanced Chemical Vapour Deposition (PE-CVD)*

The plasma-enhanced CVD process (PE-CVD) uses a glow discharge through a high-frequency voltage applied to two electrodes to create plasma from reactive gases (Figure 1-11).

A substrate is placed on the grounded electrode and the reaction gas is supplied from the opposite plate. Silicon or silicon dioxide substrates are typically used with a deposited catalyst material such as iron or nickel. After the catalyst particles are deposited, the CNTs grow from the catalyst by the glow discharge created from a high-frequency power source. The source of carbon is typically derived from a carbon-containing gas such as methane or carbon monoxide.

[42, 43]

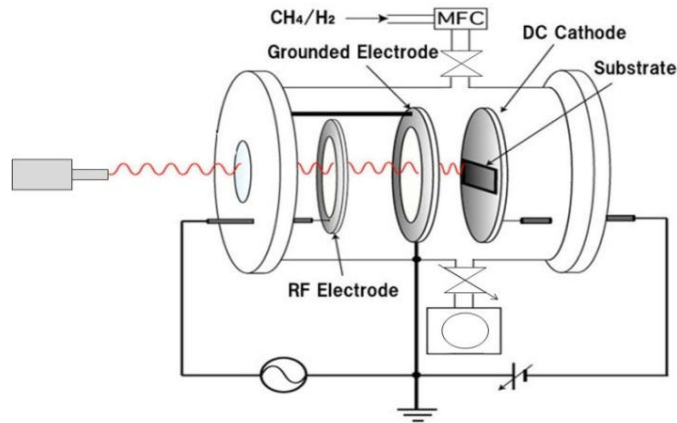

Figure 1-11: Schematic of a RF-DC Plasma CVD System. (Reproduced with permission from ref [44])

Thermal CVD and PECVD are different techniques in that PECVD is a film formation technique that causes excited species to react with one another in the gas phase. This makes deposition at lower temperatures possible. Thermal CVD requires temperature of 700°C-1200°C which brings two disadvantages. First the high temperature limits the use of certain kinds of substrates. Second, the nanotubes produced are not just randomly oriented and are not perfectly straight. ^[38] The PECVD technique overcomes these limitations by replacing some of the heat energy with energy from the plasma; this allows gas dissociation and tube formation to occur at

temperatures ranging from 500°C to 700°C. ^[45] Well aligned CNTs are grown through the adjustment of the geometry of the reactor. Using the electric field in the plasma, vertically or horizontally aligned CNTs are possible by using the electric field to guide the growth. ^[46] For example, vertically aligned CNTs were accomplished with the use of a radio-frequency (RF) plasma and a direct-current (DC) plasma generated between a RF electrode and a DC cathode (illustrated in Figure 1-11). ^[44] Without the presence of the plasma, the resulting carbon nanotubes tend to grow in a random formation.

(iii) *High-Pressure Carbon Monoxide (HiPCO)*

As its name suggests, this method is dependent on the catalytic decomposition of carbon monoxide (CO) under high-pressure (Figure 1-12). The technique was developed at Rice University in 1999 for the large-scale production of small-diameter carbon nanotubes. ^[47] The catalysts are formed in the gas phase from an organometallic precursor that was introduced into the reactor. The organometallic species decomposes at high temperature creating metallic clusters on supported catalysts. At high temperature and pressure, these clusters act as nucleation sites for SWNTs to grow on. The group at Rice University first used CO with Fe(CO)₅ to yield good quality SWNTs at a rate of approximately 450 mg/hr. ^[47] Bronikowski *et al.* ^[48] investigated the effects of various growth parameters with SWNT yield. They varied the CO pressure, catalyst concentration, and temperature to conclude that the main limit of production is due to the gradual accumulation of layers of iron atoms onto the growing nanotubes.

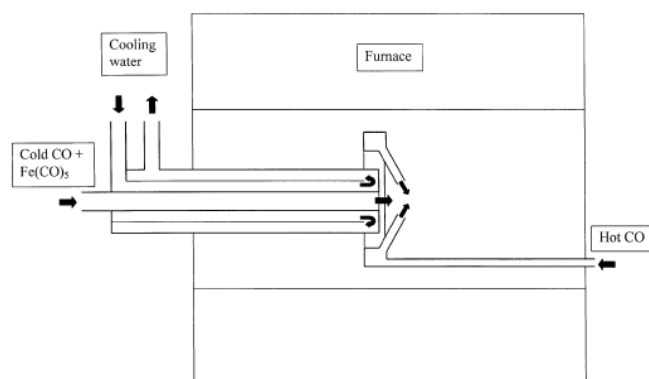

Figure 1-12: Diagram of CO flow-tube reactor with water-cooled injector and “showerhead” mixer. (Reproduced with permission from ref [47])

Other variations of the HiPCO process include using a mixture of benzene and ferrocene to react in an environment of flowing hydrogen gas. Another group deposited high quality SWNTs by the pyrolysis of acetylene at 750-1000°C in a float-iron catalyst system.^[49] In both methods catalyst nanoparticles are formed through the thermal decomposition of organometallic compounds with the only difference being the orientation of the CVD system.^[50]

1.4.2 Structure and Electronic Properties of SWCNTs

As mentioned previously, carbon nanotubes are conceptualized as a single layer of sp^2 bonded carbon atoms in a honeycomb lattice that have been rolled up into a cylinder and with ends capped as hemispherical fullerenes of the same diameter. The concept of how the CNT is rolled and its resulting parameters are illustrated in Figure 1-13. Due to van der Waals forces, CNTs will often bond to each other to form bundles.^[51] The diameter of an SWNT usually ranges from 0.5 nm to 2 nm; however there are synthesis methods that have prepared tubes from 10 nm to 1 cm.

While the length is an important parameter for many electronic applications, the direction in which the graphene sheet is conceptually rolled has a direct effect on the electronic properties of the tube. This direction is described by its chiral vector (C). In terms of developing photovoltaic devices, one important aspect is the ability to tune the band gap over a large range of wavelengths. Nanotubes are conventionally described by a pair of integers (n, m) called the chiral indices (or chirality) which describes the location of each atom in the graphene sheet. The unit cell vectors of the hexagonal lattice are denoted as a_1 and a_2 . These two parameters define the chiral vector of a given SWNT which in turn can provide the diameter and chiral angle (θ) of a tube exhibiting properties ranging from metallic, to semi-metallic, and semi-conducting. The chiral vector is therefore described as:

$$\vec{C} = na_1 + ma_2 \quad (4)$$

It follows that the nanotube diameter is thus given by:

$$d_t = \sqrt{3a_{c-c}}(m^2 + mn + n^2)^{\frac{1}{2}}\pi^{-1} = C/\pi \quad (5)$$

where C is the magnitude of the chiral vector and a_{c-c} is the carbon-carbon bond length (1.42\AA).

^[52] The angle between the chiral vector and the indices ($n, 0$) is described as the chiral angle given by:

$$\theta = \tan^{-1}(m\sqrt{3}/m + 2n) \quad (6)$$

In both semiconducting and metallic SWNTs, the dominant optical transitions are defined by their diameter and chiral vector and the bandgap in semiconducting SWNTs vary inversely with diameter.

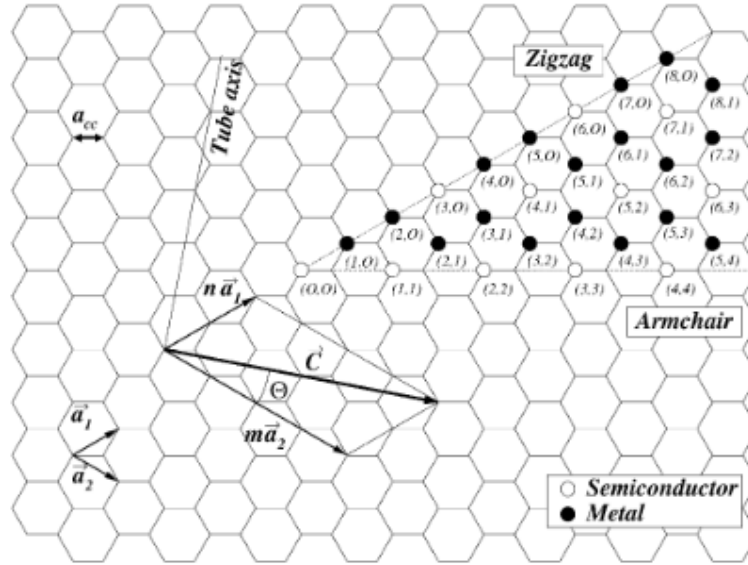

Figure 1-13: Graphene sheet showing indexed lattice points (n,m) . \vec{a}_1 and \vec{a}_2 are the unit cell vectors of the two-dimensional lattice and the chiral angle, θ , is defined as the angle between the chiral vector \vec{C} and the zigzag axis. The chiral vector \vec{C} and chiral angle θ define the chirality $(2,4)$ (Reproduced with permission from ref [56])

Specifically, all CNTs with chiral indices such that $n - m = 3j$ (where $j = 0$) exhibit metallic properties; those with $n - m = 3j$ (where $j \neq 0$) are considered small gap semiconductors or semi-metallic CNTs. Finally when $n - m = 3j \pm 1$, they are large-gap semiconducting CNTs with a band gap around 1 eV for 0.7 nm of diameter. In terms of rolling up a graphene sheet, if the tube is rolled along the chiral vector which is dictated by chiral indices such that $n = m$, and a chiral angle where $\theta = 0^\circ$, it is labelled as an “armchair” carbon nanotube (since the carbon atoms in the graphene lattice form a pattern looking like an armchair). If, however, the tube has the chiral indices $(n,0)$ and the chiral angle is equal to 30° it is called a “zigzag” nanotube (since in this case the end of the tube makes a zigzag pattern). Finally, if the graphene sheet is rolled with a chiral angle between 0° and 30° , it is simply called a chiral nanotube and has indices where $m \neq$

0 or n and n is any positive integer. Optical properties of SWNTs are typically identified using absorption and luminescence spectroscopy which are discussed in the following chapter. ^[53-55]

In order for the SWNTs to optimally perform in a dye-sensitized solar cell, nanotubes of a particular chirality, and therefore electronic type, need to be separated from the mixture. In the ideal situation, a separation process would result in a population of SWNT species with the same electronic type, diameter, and length.

1.4.3 Review of Chirality Separation Methods

In order for a CNT separation strategy to be effective, the method must be reproducible and iterative (such that further iterations improve the purity of the sample), scalable, non-destructive (such that desired properties are not degraded during the process), compatible for a large range of types of CNTs, and affordable. ^[57] The following section is a review of post-growth techniques in literature which have been shown to successfully separate CNTs in varying degrees.

Selective Chemistry and Functionalization

Both theoretical and empirical data have shown that SWNTs will interact with some compounds depending on their electronic structure and diameter. Interactions between CNTs and various compounds often result in a functional group attached, or an encapsulation, around the tubes (Figure 1-14) which leads to separation using an assortment of techniques such as chromatography, centrifugation, and electrophoretic separation. ^[58] Chemistry on CNTs can be

classified into two types: exohedral functionalization and endohedral functionalization. ^[59] This section will focus more on exohedral functionalization since it is the more selective of the two methods.

Endohedral functionalization (Figure 1-14 E) is a type of modification of CNTs where nanoparticles are inserted into the CNT interior. ^[60] This method is done in one of two ways: either putting the CNT sample inside a suspension containing nanoparticles so that the sample can be penetrated from inside, ^[61] or, the CNT sample is filled with a material that reacts and produces nanoparticles which are trapped inside the tube. ^[62] This method of functionalization is particularly interesting for the development of nanowires and storage applications. For example the creation of nanowires has been done by encapsulating noble metals and metallofullerenes in CNTs. ^[63]

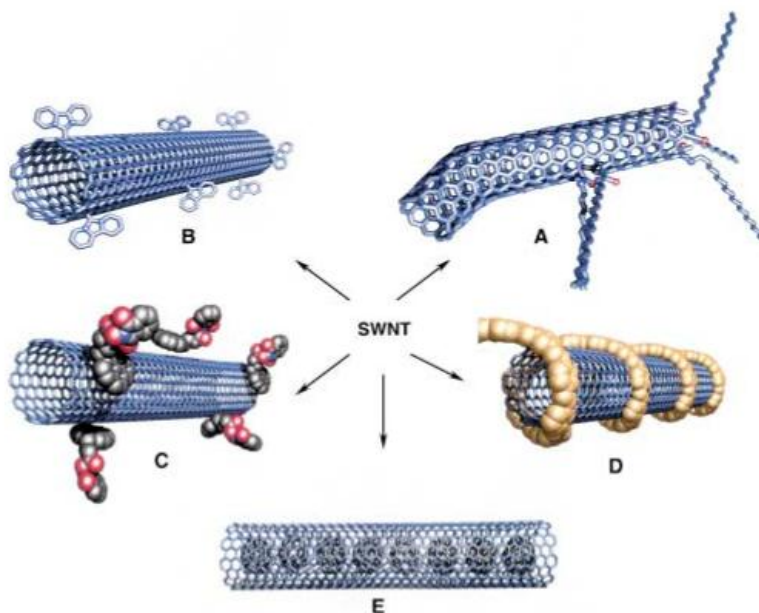

Figure 1-14: Methods to chemically functionalize CNTs: A) Covalent functionalization at defect sites or open ends. B) Covalent sidewall functionalization. C) Noncovalent functionalization with surfactants. D) Noncovalent functionalization by polymer wrapping. E) Endohedral functionalization (Reproduced with permission from ref [62])

Exohedral functionalization is the modification of the external walls of the CNT (Figure 1-14 A-D). This method is subcategorized into three methods:

1. Noncovalent functionalization: Typically this kind of functionalization is defined by either encapsulation of the CNTs from a surfactant (Figure 1-14 C), or wrapping the CNT with a polymer (Figure 1-14 D). Due to the CNT's strong π - π interactions, they have poor solubility in water. To make them soluble in water and organic solvents, a variety of polymers and amphiphilic or π -surfactants can be used to encapsulate or be wrapped around the CNT. Not only does this process increase solubility but also aids in individualization after ultrasonication. Conventional surfactants such as sodium dodecyl sulphate (SDS),^[65] sodium dodecyl benzene sulphonate (SDBS),^[66] and sodium cholate^[67] have been studied and have become the standard surfactants in CNT chemistry. These surfactants successfully attach themselves to the CNT surface and not only interact through π - π interactions but their unpolar tail may wrap around the nanotube as well. This concept of wrapping is applied to many synthetic and bio-polymers. A notable example was published by Zheng *et al.*,^[68] who reported a method allowing purification of 12 major semiconducting CNT chiralities by wrapping DNA of different sequences. The sequences recognize and enable chromatographic purification of a particular chirality from the mixture. This is accomplished through exhibiting a periodic purine-pyrimidines pattern which undergoes hydrogen bonding to form a two-dimensional sheet. The sheet folds over the tube into a three-dimensional barrel providing the structural basis of CNT selection. To filter the different CNTs out into electronically specific batches, an ultracentrifugation^[69] or a chromatographic^[70] method is used and is described later in this chapter.

2. Covalent functionalization at defect sites or open ends (Figure 1-14 A): this method uses the defects or open ends of grown CNTs to anchor functional groups. The process of growing carbon nanotubes often results in material with impurities, such as amorphous carbon, fullerenes, and catalyst residuals.^[71] In the case of HiPCO carbon nanotubes, where the residual catalyst particles are encased in a carbon shell, the removal of these impurities without damaging the CNTs is troublesome.^[72] A common method employed is to oxidize the impurities which have a higher reactivity than the 1D sp^2 lattice of the carbon nanotubes. Since the end caps of the CNT are not perfect sp^2 cylinders, the result is a partial oxidation of the material.^[73] Aside from the ends, CNTs have various defects due to topological rehybridization. The process of oxidation usually results in the opening of the sp^2 carbon lattice at the defect sites yielding the formation of oxygen containing functional groups – commonly carboxylic acid.^[74]

Various means of purification and functionalization have been used, including refluxing in nitric and sulfuric acid,^[75] hydrogen peroxide,^[76] and potassium permanganate.^[77] Sonication is often used to expedite the reaction generating a larger amount of functional groups on the defect sites.^[78] These functional groups often act as an anchor for secondary functionalization, which in turn, aid in solubilizing CNTs in polar solvents.^[79, 80] Aside from physical degradation of the carbon nanotubes, the process regularly introduces negative effects on the electronic properties of the tubes as well.^[81]

3. Covalent side-wall functionalization (Figure 1-14 B): Many selective covalent side-wall functionalization techniques have been developed that use diazonium salts to functionalize metallic CNTs.^[82] The use of diazonium as a basis for functionalization

was first performed electrochemically using buckypaper as a working electrode. The reaction was done in situ decomposing the diazonium salts to radicals by the electron uptake of the CNTs.^[83] Later, a modification of this reaction was done with water as a solvent.^[84, 85] The availability of electrons near the Fermi level in metallic SWNTs encourages bonding interactions leaving the semi-conducting CNTs insoluble.^[86, 87] Similarly, nitronium ions,^[88] hydrogen peroxide,^[89] and carbenes^[90] have also been found to be methods of enriching the metallic population of SWNT species; however azomethine ylides (through cycloaddition) showed preference towards semi-conducting tubes.^[91] This was achieved by pre-organizing the starting N-oxides on the nanotube surface prior to generating the reactive ylide. Following functionalization, the metallic SWNTs were separated from the functionalized semiconducting SWNTs through inducing the semiconducting tubes to solubilize in the presence of lignoceric acid.^[91]

Ultracentrifugation

Centrifugation is a widely used process to separate mixtures by using their inertia. The denser components will travel away from the center of rotation resulting in the most dense material building up at the end of the centrifuge tube. When the effective gravitational force on the tube is increased, more of the dense components begin to precipitate and collect at the bottom of the tube. The less dense material is then collected in the supernatant. A very popular method to sort various lengths and diameters of carbon nanotubes is to use ultracentrifugation. This technique conventionally works by dispersing the CNTs into a constant density medium and ultra-centrifuging the CNTs which are then separated according to their sedimentation

coefficient. The problem of relying solely on their sedimentation coefficient is that the sorting results end up convoluted by several physical parameters (length, diameter, etc.). A paper published by O'Connell *et al.* in 2002^[92] reported the separation of individual SWNTs from bundles, ropes, and catalyst impurities by first suspending the CNTs in heavy water and sodium dodecyl sulphate (SDS). They ultra-centrifuged the solution at 122 000g for 4 hours resulting in the individual SWNTs in the supernatant and the rest of the components collected at the bottom.

A density gradient was introduced into the procedure using iodixanol (a non-ionic density gradient medium) which allowed for SWNTs to be sorted by their buoyant density.^[93, 94] In density gradient ultracentrifugation (DGU), a density gradient is created in a centrifuge tube before loading the surfactant/SWNT solution. This gradient is created by either layering the medium in discrete steps, or by using a linear gradient generator. During ultracentrifugation, the SWNTs migrate to the region where their density is the same as the density of the gradient (this is called the isopycnic point). This causes layers of homogeneous CNTs to form in the centrifuge tube according to their density which, if the surfactant surrounding each CNT is uniform, will depend on the diameter of the CNT. In Figure 1-15, bands of semiconducting chiralities are visibly distinguishable. Electronic-type sorting was achieved by DGU when using co-surfactant mixtures of sodium cholate (SC) and SDS.^[95, 96] This is due to unequal binding of the two surfactants as a function of SWNT polarization, resulting in subtle differences in density depending on the electronic type, bandgap, and diameter of the SWNT. When this technique is done in several iterations, purities approaching 97% can be achieved.

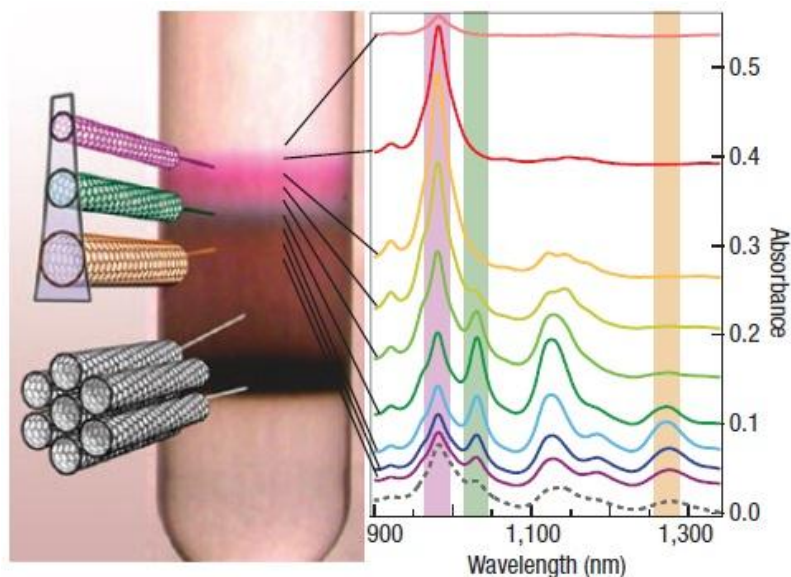

Figure 1-15: SWNT sorting using density gradient ultracentrifugation and its corresponding optical absorbance spectra for each fraction. (Reproduced with permission from ref [95])

Sucrose was experimented with as a density gradient medium in work published by Yanagi *et al.* in 2008.^[97] Sucrose is a common medium used in the separation of macromolecules and is more cost effective than iodixanol. It was reported that by lowering the temperature during the ultra-centrifugation process and tuning the concentrations of the co-surfactants, both metallic and semiconducting SWNTs were retrieved in purities of 69% and 95% respectively. Zhao *et al.*^[98] achieved a 97% purity of (6,5) SWNTs by further tuning the encapsulation of the co-surfactants. In this work sodium deoxycholate (DOC) was used to restrict the SDS wrapping around the individual tubes resulting in a change of density dictated by the chirality.

Electrophoresis

CNTs have dimensions that are similar to many biomolecules and therefore it follows that techniques used to separate and sort biomolecules can be used to separate and sort carbon nanotubes as well. Electrophoretic separation is one such technique that has been shown to sort SWNTs by their physical and electronic properties. Conventionally a direct current is applied through a gel and the SWNTs are sorted by their relative mobility. The tubes with the smallest molecular weight migrate the fastest allowing for assortment by length. It would seem that this does not lend any electronic separation at all except that during the tip sonication process of debundling the tubes also cuts the tubes. How much the tubes are cut is dependent on the diameter of the tube which indirectly creates a trend between tube length and diameter. ^[99, 100]

Another approach was developed in 2003 ^[101] which used an alternating current dielectrophoretic method to separate metallic SWNTs from the semiconducting ones. When a CNT suspension is placed on an array of microelectrodes and under alternating current, an electric field gradient is created prompting the movement of metallic and semiconducting tubes in opposite directions. The metallic tubes were attracted to the array leaving the semiconducting tubes in the solvent. Shin *et al.* ^[102] further developed the concept by finding a scalable method to separate SWNTs using a H-shaped microfluidic channel (shown in Figure 1-16). There are two inlets and two outlets to allow two laminar streams, one with the suspended CNTs and the other only a surfactant solution, to flow through the channel. The technique works by using a dielectrophoretic force from an embedded electrode to extract the metallic CNTs from the flow of suspended CNTs to the surfactant solution. This method only allows for the separation of metallic tubes from the semiconducting ones and not the differences in bandgap of the

semiconducting tubes themselves. A more recent approach uses a dielectrophoretic field-flow fractionation (FFF) technique to sort mixtures of SWNTs by diameter, thereby opening the possibility to use electrophoretic techniques to isolate semiconducting species by their bandgaps.

[103]

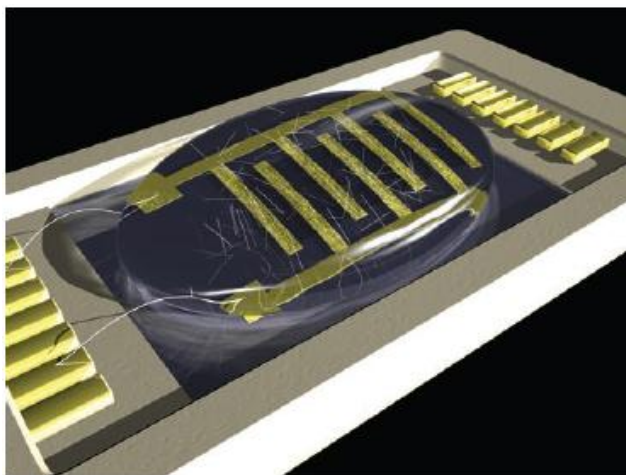

Figure 1-16: Dielectrophoresis of carbon nanotubes. Semiconducting CNTs (white) remain in solution while the metallic CNTs (black) deposit themselves on the electrode array. (Reproduced with permission from ref [101])

Chromatography

Using biochemical methods to separate macromolecules, chromatography effectively separates not only semi-conducting nanotubes from metallic, but also different chiralities of semi-conducting species. Ion-exchange chromatography^[70] of DNA-wrapped SWNTs (Figure 1-17) has shown a lot of promise in separating individual semiconducting chiralities. In this study, HiPCO SWNTs are individually wrapped with single-stranded DNA in an aqueous solution. After chromatography, CNTs separated by chirality was confirmed via absorption, fluorescence

and Raman spectroscopy. Each strand of DNA contains a different sequence and with each sequence there is affinity for a different chirality of SWNT. Therefore, the quality of SWNT sorting depends on DNA with a sequence of $(GT)_n$ where n is 10 to 45. While the results of this method report a very high purity of single-chirality tubes, removing the DNA strands post-separation remains a challenge. Furthermore the length of the tubes introduces a convolution of results during the ion-exchange chromatography stage of separation.

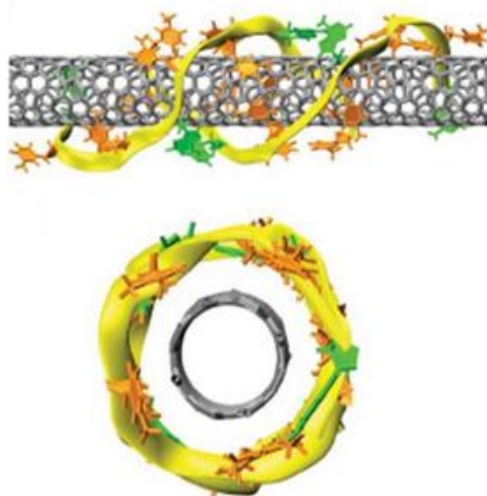

Figure 1-17: A 2D DNA sheet composed of two hydrogen-bonded anti-parallel ATTATTTATTT strands wrapped around a (8,4) tube. (Reproduced with permission from ref [68])

Gel filtration, or size-exclusion gel chromatography, is a simple technique that has opened the possibility of scaling up the separation of CNTs.^[104] Separation into semiconducting and metallic fractions was initially done in work by Moshhammer *et al.*^[105] which demonstrated the ability of an amide-functionalized hydrogel to separate a mixture of SWNTs in a solution of sodium dodecyl sulphate (SDS). Liu *et al.*^[106] made further progress by using several syringes in a vertical column and a single surfactant. After multiple iterations, the group succeeded in

separating 13 different semiconducting chiralities with ranging purities from a mixture of HiPCO tubes. Jain *et al.*,^[107] slightly modified that process to separate a relatively pure (6,5) chirality from a mixture of HiPCO tubes in a single iteration.

The gel filtration method separates macromolecules (such as proteins and polymers) by their size in columns of gel beads with small pores. Small molecules spend more time within the pores of the medium and therefore move more slowly through the column than larger molecules. The small particles enter many pores in the gel, equilibrating between the gel and the moving buffer. Meanwhile, medium-sized particles enter only some of the pores in the gel equilibrating between the gel and the moving buffer. Large particles enter very few pores and as a result travel quickly through the column. Prior to loading the column, the CNTs were first suspended in a 2 wt% SDS solution and homogenized in a tip sonicator for 20 hours. In the first columns, tubes with the largest affinity for the gel were removed from the mixed-chirality solution while the latter columns removed tubes with less affinity (Figure 1-18). After the tubes ran through the column, the unbound tubes were washed with a 2 wt% SDS solution and then the tubes were eluted from each syringe independently using a 5 wt% SDS solution. Since CNTs that were trapped in the gel were easily eluted with a higher concentration of surfactant, this suggests that it is the amount of SDS coating the tubes that alters their interaction with the gel. Therefore it is believed that the chirality-dependent separation of the nanotubes originates from the different amounts of SDS micelles on different CNTs of different chirality. It has been reported that the morphology and coverage of SDS on nanotubes is dependent on tube structure.^[106-108]

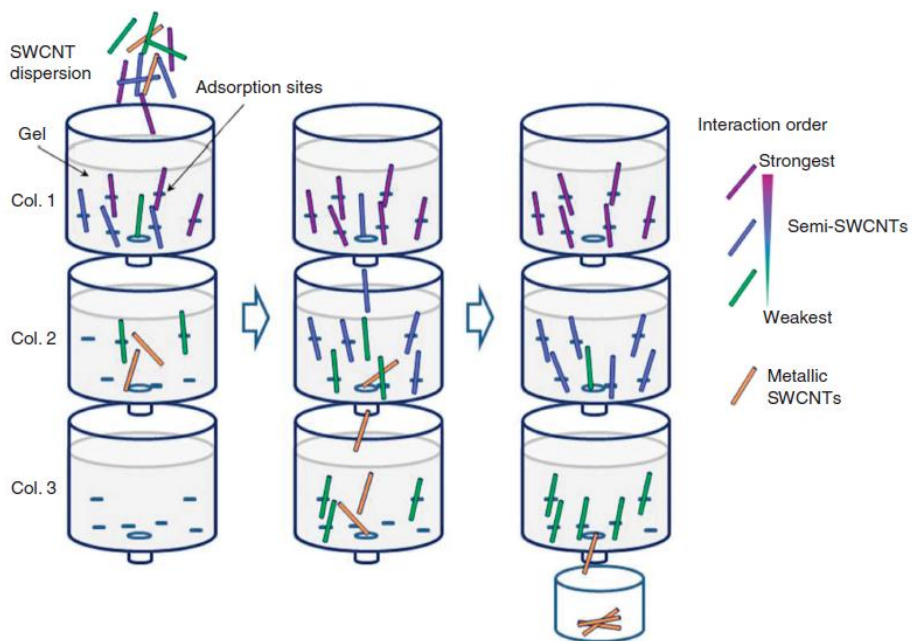

Figure 1-18: Schematic of a gel chromatography technique using multiple columns (Reproduced with permission from ref [106])

The Kataura group ^[106] (Liu *et al.*) explored this concept further by analyzing the relationship between bond curvature and SDS coverage. They found that there is an increasing relationship between the smallest bond curvature radius belonging to a specific chirality and the separation order. Comparing this with the relationship between separation order and diameter, this would indicate that the tubes which interact with the gel the strongest are the tubes with the smallest diameter. The differences in the surface π -electron states of the varying semiconducting chiralities are responsible for the different curvatures. Metallic nanotubes are fully covered in SDS and therefore have a much weaker interaction with the gel.

1.5 Thesis Objective

As discussed previously, DSSCs containing carbon nanotubes form Schottky junctions with TiO_2 permitting electron transport to occur and limiting electron trapping inside the nanostructured film. There have been many studies done where single-walled and multi-walled CNTs have been coated by the TiO_2 in the anode film. One drawback to this, however, is that rarely are the tubes completely coated leaving carbon exposed to the electrolyte catalyzing the triiodide conversion into iodide. For this reason, creating a film of CNTs and then printing a film of TiO_2 on top of the CNT layer may decrease the amount of unwanted reduction in the electrolyte. Another drawback to a TiO_2 /CNT composite electrode is the inevitable competition between the CNTs and the dye for light absorption. The main objectives can be summarized as follows:

- Implement a chirality separation process of CNTs to obtain single chiralities in a fast and efficient process;
- Minimize the competition for light between the film and the dye by using a specific chirality, and thus a specific bandgap, It is expected that a film where all of the tubes have the same band-gap will facilitate electron transport through the anode and improve the DSSC efficiency; and
- Decrease unwanted reduction in the electrolyte, thus improving DSSC efficiency, by separating the CNT films and the TiO_2 layer.

In this study chiralities (6,4), (6,5), and (7,3) were chosen and separated via size exclusion gel chromatography. These particular chiralities were selected as their respective CNT

species have band-gaps in the range of 2.1-2.5 eV and thus have absorption bands that only partially overlap with the N719 dye absorption spectra.

Chapter 2

CHARACTERIZATION METHODS

2.1 Optical Spectroscopy Techniques

Spectroscopy is the study of the interaction between matter and electromagnetic radiation. When radiation interacts with matter, a number of processes can occur, including reflection, absorption, scattering, and fluorescence. Optical absorption spectroscopy measures the absorption of electromagnetic radiation in the subject material.

When light travels through an absorbing medium, its intensity decreases according to the Beer-Lambert law ^[109]:

$$I(L) = I_o e^{-\alpha Lc} \quad (7)$$

where I_o is the intensity of the incident light, α is the absorption coefficient, L is the optical path length, and c is the concentration of absorption in the material. Measuring the transmitted intensity relative to the incident intensity, the absorption for a particular wavelength can be found by:

$$A = -\ln\left(\frac{I}{I_o}\right) \quad (8)$$

When discussing the optical properties of carbon nanotubes or titanium dioxide, one is specifically referring to its absorption, luminescence, and Raman scattering mechanisms. In this study, the optical properties of the CNTs are important as the electronic structure of a given nanotube depends on its chirality. Therefore, the optical properties of a tube of a particular electronic structure can provide a wealth of information such as the diameter, chirality, and electronic nature of the sample. ^[110] The following sections introduce the basic concepts of the optical spectroscopic techniques used.

2.1.1 UV-vis-NIR Spectroscopy

Ultra-violet-visible-near infrared spectroscopy (UV-vis-NIR) is a technique where the incident light is scanned in the ultraviolet, visible, and near infrared regions of the spectrum. It is often used for the characterization of SWNTs, since it measures light absorbed in the region dominated by transitions between the valence and conduction bands.

As previously discussed in Chapter 1, a carbon nanotube can be described as either semiconducting, semi-metallic, or metallic. The energy gap (E_g) of the semiconducting CNT is related to the chirality, which is proportional to the inverse of the diameter of the tube. ^[110] The electronic properties of a quasi-one-dimensional SWNT is described by a continuous electronic density of states (DOS) which divides into a series of peaks, known as van Hove singularities. The carbon atoms have p electrons which yield a large π -electron system. The optical absorption spectrum in the UV-vis-NIR range shows the characteristic absorption behaviour of SWNTs, due to the transitions between the first (E_{11}) and second (E_{22}) pairs of singularities in the density of states. Each (n,m) indices exhibits a different set of van Hove singularities in its valence and

conduction bands. Therefore, the optical absorption spectra can be used to identify the diameters and chiralities in a SWNT sample. [111-114]

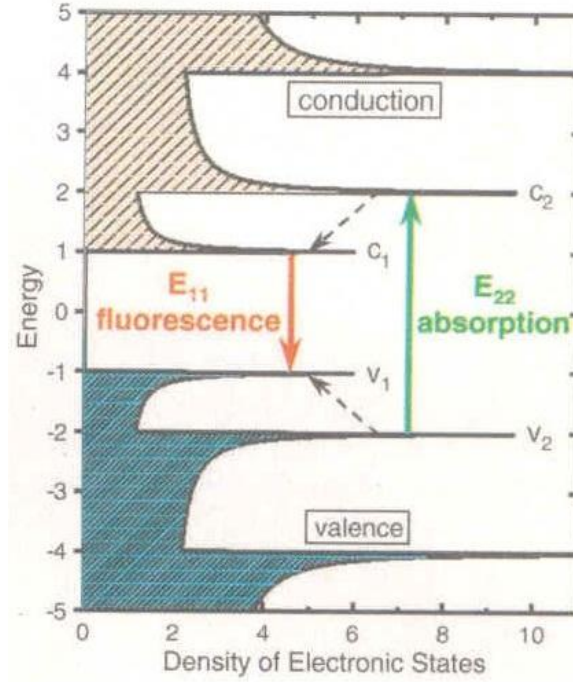

Figure 2-1: Density of electronic states for a single nanotube. Solid arrows represent optical absorption and emission transitions while dashed arrows represent nonradiative relaxation. (Reproduced with permission from ref [55]).

A typical absorption spectrum of a mixed SWNT sample consists of broad absorption peaks: E_{11}^M , E_{11}^S , and E_{22}^S which represent the first peak in the DOS of the metallic SWNTs, and the first and second transitions in the semiconducting SWNTs respectively. Based on the tight-binding model, the energy of each transition is described by:

$$E_{11}^S = \frac{2a_{cc}\gamma_0}{d} \text{ and } E_{22}^S = \frac{4a_{cc}\gamma_0}{d} \text{ for semiconducting nanotubes} \quad (9)$$

$$E_{11}^M = \frac{6a_{cc}\gamma_0}{d} \text{ for metallic tubes.} \quad (10)$$

where a_{cc} is the distance between carbon atoms and γ_0 is the tight binding nearest neighbour hopping constant. ^[115]

Absorbance peaks between 800-1600 nm are assigned as the first inter-band transition $v_1 \rightarrow c_1$ in semiconducting SWNTs (E_{11}^S). Second inter-band transitions $v_2 \rightarrow c_2$ in semiconducting SWNTs (E_{22}^S) are peaks between 500-900 nm. Absorbance peaks $v_1 \rightarrow c_1$ created by metallic SWNTs (E_{11}^M) lay between 400 – 600 nm. ^[116] For the reasons discussed previously, where the absorption peak is located for any transition is dependent on the particular diameter and chirality of the nanotube. Since the transition energy depends on the diameter and electronic properties of the tube, many parameters including the growth method, diameter dispersion, and purity of the tubes can affect the spectra of the tubes making analysis difficult.

2.1.2 Photoluminescence Excitation (PLE) Spectroscopy

If a sample contains more than a single chirality, the peaks in the UV-vis-NIR spectra can be very broad. This becomes accentuated if two species in the same sample have absorption wavelengths that are close together. To identify semiconducting species in the sample, a photoluminescence map can be constructed to accompany the absorption spectra. The figure in the previous section (Figure 2.1) can also be applied to illustrate the processes of absorption and emission of photoluminescence in a DOS diagram for a semiconducting SWNT. To excite the nanotube for PL characterization, transitions involving the second van Hove singularity are

generally used. Photoluminescence excitation spectroscopy (PLE) is used to determine all of the semiconducting chiralities in the sample. This technique records the photoluminescence emission spectra while the excitation wavelength changes. From this one can create a 3D map of the PL intensity vs. the emission and excitation wavelength (Figure 2.2). Each spot in the map represents a single (n, m) species. Since metallic tubes do not luminesce, having a large amount of metallic species in the sample will dilute the semiconducting species causing them to be less intense in the map. Therefore, to produce the desired results, it is important to limit the amount of metallic tubes in the sample.

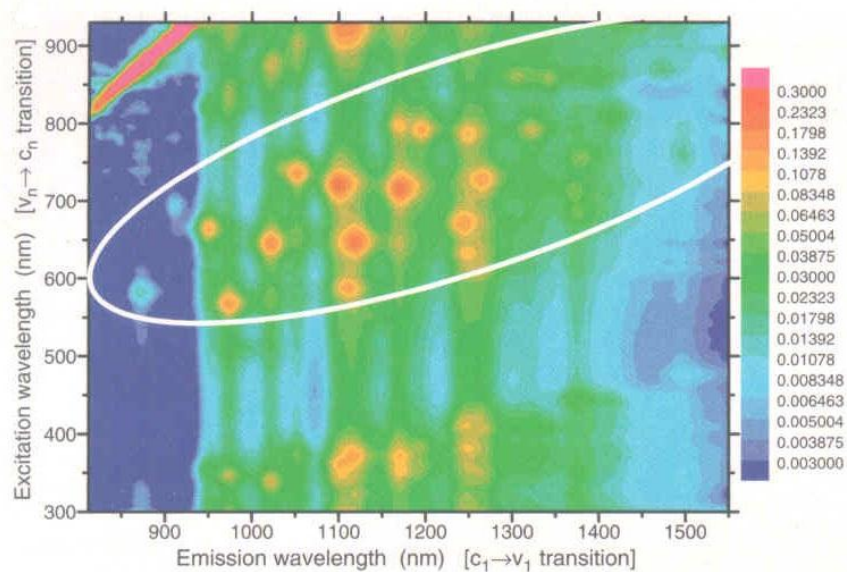

Figure 2-2: PLE Map of mixed SWNTs grown via HiPCO method and dispersed in SDS (Reproduced with permission from ref [55]).

2.1.3 Infrared (IR) Spectroscopy

Infrared spectroscopy is a fast, non-destructive, and fairly cost-effective technique to characterize materials. The infrared portion of the electromagnetic spectrum ranges from 4000 to 400 cm^{-1} . When a molecule is exposed to infrared radiation, it will absorb the radiant energy if it matches the vibrational energy of that molecule. IR radiation causes the excitation in the vibrations of covalent bonds including the stretching and bending modes. Generally speaking the IR spectrum is split into two regions: the group frequency region which lies from 3600 cm^{-1} to approximately 1250 cm^{-1} and the fingerprint region which is located from 1200 cm^{-1} to 600 cm^{-1} . The fingerprint region is useful as small differences in the structure of a molecule results in large changes in the peaks in this region of the absorption spectrum. ^[117-119]

IR spectroscopy is a technique mainly used to clarify the structure of a material and determine its attached functional groups. Since individual interatomic bonds may vibrate in several different motions, each bond may absorb at more than a single frequency. While stretching modes typically result in stronger absorption peaks than bending modes, the absorption due to bending vibrations are useful in differentiating between similar bonds. ^[119, 120]

Since carbon nanotubes absorb quite strongly in the IR range, not a lot of information is gathered in comparison to other optical spectroscopy techniques. Therefore in CNT characterization, IR spectroscopy is typically used to analyze impurities resulting from the growth process and to identify functional groups covalently attached to the nanotube surface. ^[121] The application of IR spectroscopy in the study of CNT surface chemistry provides a means to observe the interactions occurring at the surface during absorption and to determine the structure of the species absorbing the radiation. In an early transmission IR study, two absorption peaks

were recorded: a weak peak at 868 cm^{-1} and a broad asymmetric peak at 1575 cm^{-1} .^[122] In similar studies using Fourier-transform IR spectroscopy and different carbon nanotube symmetries, absorption peaks were located at approximately 850 cm^{-1} and 1590 cm^{-1} . It was found that these phonon modes were present regardless of the diameter of the tube studied.^{[123,}
^{124]} Work involving the functionalization of CNTs found that the peaks of carboxylic groups absorb at an IR frequency of 1719 cm^{-1} , and create broad bands ranging between 2800 cm^{-1} and 3500 cm^{-1} .^[125-127]

2.1.4 Raman Spectroscopy

Raman scattering is inelastic scattering of a photon (usually from a laser in the visible, near infrared, or near ultraviolet spectrum) off of a molecule. Most types of scattering are elastic or Rayleigh scattering; however, a small fraction of incident photons are inelastically scattered by interacting with optical phonons. The scattering process can be broken down into three main steps: 1. Absorption of the incident photon with an energy $\hbar\nu$ and consequently exciting an electron; 2. The generation and absorption of a phonon ($\hbar\omega$); and 3. Relaxation of the electron from its excited state and the emission of a photon ($\hbar\nu - \hbar\omega$).

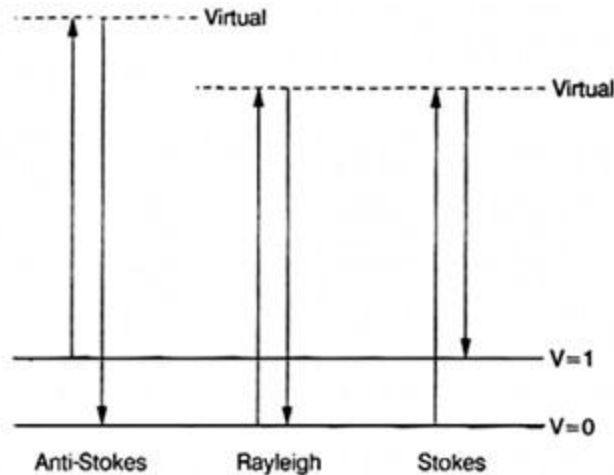

Figure 2-3: General energy level diagram of Raman and Rayleigh scattering (Adapted from ref [129])

Conventionally there are two types of Raman scattering: Stokes scattering and anti-Stokes scattering. As the photon travels through the material there is either a loss or gain in the photon energy. Anti-Stokes Raman scattering occurs when an electron in a molecule is initially in a higher electronic state and, following interaction with the photon, it relaxes to its ground state, resulting in the scattered photon having more energy than the incident photon. Stokes Raman scattering is the opposite case, where the absorption of a photon excites the electron and then it relaxes to still a higher electronic state from where it started. The shift in wavelength of the material provides substantial information on the sample being analyzed. In Raman spectroscopy only the Stokes part of the spectrum is used because it has greater intensity.

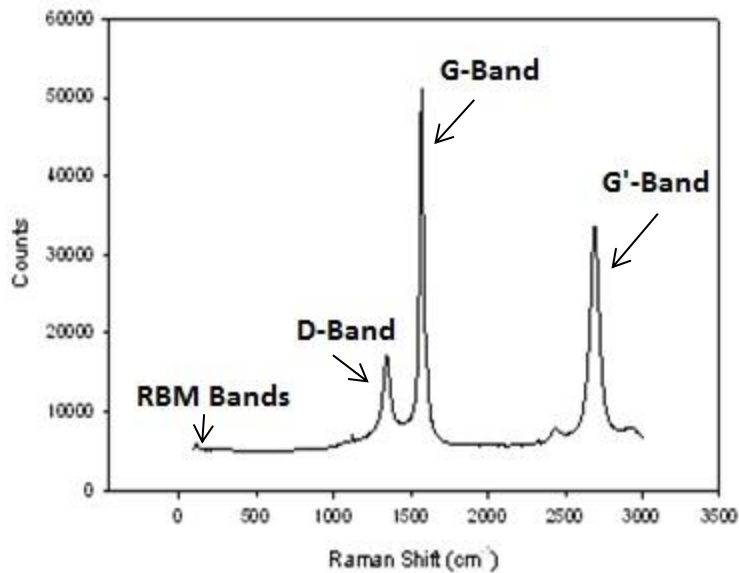

Figure 2-4: Raman spectrum of a mixed multi-wall and single-wall carbon nanotubes sample

The Raman spectrum of CNTs can be categorized into three distinguishable features: the radial breathing mode (RBM), the D mode, and the high energy mode (HEM). Each of these features demonstrates different properties of SWCNTs. From these categories two dominant features appear in every Raman spectra of CNT samples: the radial breathing mode, which is usually found in the range of 100-300 cm^{-1} , and the double peak structure found around 1500-1600 cm^{-1} . These bands signify the difference between SWCNTs and other forms of carbon since these components of the Raman spectra are not observed in any other sp^2 bonded carbon material. The RBM band is a low-frequency band that arises from the scattering in the radial breathing mode. This is due to the symmetric in-phase displacements of all of the carbon atoms around the tube. This mode provides some indication of the diameters in the sample, and also identifies whether the tubes are multi or single-walled. In MWNTs, the RBM band can be seen if

the inner tube diameters are very small (less than 5nm usually). The frequency of the RBM (ω_{RBM}) band depends on the diameter of the tube and is expressed by:

$$\omega_{RBM} = \frac{A}{d} + B \quad (11)$$

where d is the diameter of the tube, A is a proportionality constant, and B is a damping variable caused by the environment around the tube. If the tube is isolated, B is expected to be zero. ^{[130-}

132]

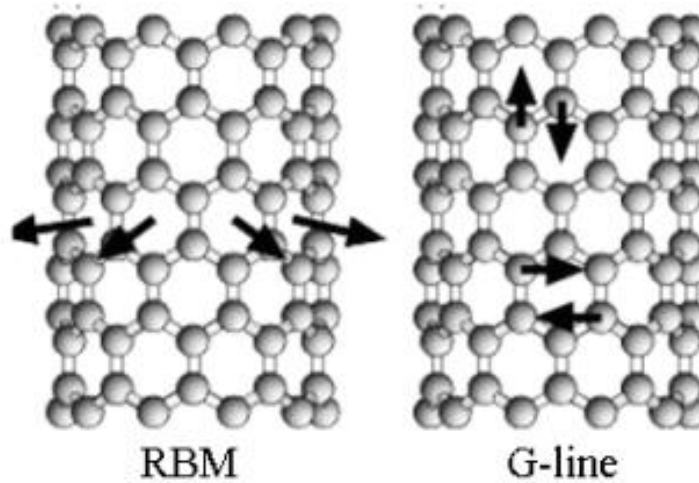

Figure 2-5: Illustration of the atomic vibrations responsible for the RBM and G bands. (Reproduced with permission from ref [128])

The double peak structure, referred to earlier, is associated with the G-band, tangential vibrational modes of the CNTs, and is associated with the Raman spectra of graphite. The G band in carbon nanotubes is due to the curvature of the graphene sheet and is split into two peaks: the G^- peak and the G^+ peak. The G^- peak has a lower frequency and is more visible in semiconducting tubes, as in metallic tube samples it also has a lower intensity and is much broader, making it less visible. The G^+ peak, however, is at a slightly higher frequency and has

no significant difference in frequency or width between metallic and semiconducting tubes. In samples of MWNTs where a large portion are metallic, the G-band is visible as a single peak.

The D-band is found at frequencies between 1250 and 1450 cm^{-1} , while its overtone appears at approximately double the frequency ranging between 2500 and 2900 cm^{-1} . The D-band is commonly called the defect band because the intensity of the D band is related to the number of defects in the tube. The approximate intensity and width of the D band can be used to determine the fraction of graphitic material present in the sample. ^[131, 133] A general idea of the quality of nanotubes grown can be obtained by taking the ratio of the G and D bands. Furthermore the intensity of the D band can be used to oversee damage being inflicted on the sample from various processes used in its purification, such as tip sonication or centrifugation.

2.2 Surface Characterization Techniques

In some subfields of materials science, understanding the physical and chemical structure of the surface of a material is more important than the bulk of the material. The general methods used to analyze the surface are physical in that the images of the surface are derived from microscopy techniques. These techniques can determine the surface roughness, area, general alignment and porosity of the material. While this information is useful to surface characterization, they provide little information regarding the chemical nature of the material. Spectroscopic methods provide qualitative and quantitative chemical information about a solid from a few angstroms to a few nanometers deep. It is ideal to use both microscopic and spectroscopic techniques in conjunction, as together they provide not only information of the physical surface, but also identification of the chemical species and their concentrations.

2.2.1 Scanning Electron Microscopy (SEM)

A scanning electron microscope is the classical method to see objects at the nanoscale and obtain surface information at a higher resolution than when using regular microscopy. The SEM works by generating a fine beam of electrons from a tungsten filament source or for higher resolution, a field-emission electron gun. The electrons are accelerated to energies between 1-30 keV. The electrons flow in a vertical path through a magnetic condenser and objective lens system reducing the spot size to between 2-10 nm before impinging on the sample surface.^[134] Several types of electrons are then produced: backscattered, secondary, and Auger. X-ray fluorescence photons and other photons of various energies are also generated from the process. In SEM, the backscattered and secondary electrons are used to produce the image. The angle at which the electrons strike the surface determines the intensity of the emission of secondary and backscattered electrons. The electrons are ejected from the sample to detectors which convert the electron current into a signal that is sent to a screen producing the final image. The magnification produced by the SEM is a ratio between the field scanning of the sample and the dimensions of the final image. While transmission electron spectroscopy (TEM) creates images with a resolution an order of magnitude higher than SEM techniques, SEM images rely on the surface mechanics rather than transmission and can therefore produce images of bulk samples with a greater depth of view. This results in the production of images that are a good representation of the overall 3D structure of the sample.^[134-137]

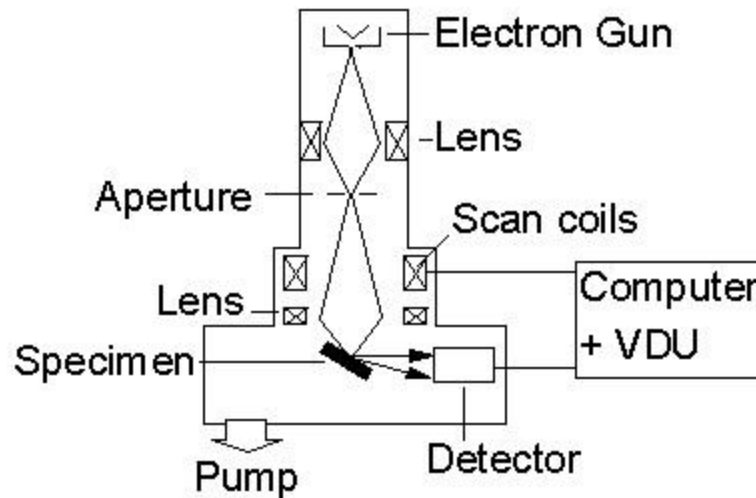

Figure 2-6: Schematic of a Scanning Electron Microscope (Reproduced from ref [136])

A common sample preparation technique consists of coating the sample with a conductive material (such as gold, or platinum) approximately 10 nm thick. This is required as SEM cannot image samples that are not conductive and would otherwise charge the sample. SEM is typically used to analyze the general alignment of CNTs and view them as a bulk sample. [136-138]

2.1.5 X-Ray Photoelectron Spectroscopy

X-Ray photoelectron spectroscopy (XPS) is a surface technique used to accurately detect and quantify the elemental composition of a sample. Additionally, it can determine the chemical and electronic state of the elements making up the material's composition. An XPS spectrum is obtained by exposing a material to a projected beam of aluminum or magnesium x-rays causing

electrons to escape from the top 1-10 nm of the sample. Simultaneously the kinetic energy and number of electrons that escape the surface of the material are measured under a very high vacuum. The electrons emitted have kinetic energies proportional to the energy of the incident radiation. Since the energy of the incident ray wavelength is known, the kinetic energy and thus the binding energy of the ejected electron can be found by:

$$E_{kinetic} = h\nu - E_{binding} - \phi \quad (12)$$

where $E_{kinetic}$ is the kinetic energy of the electron, h is Planck's constant, ν is the frequency of the incident radiation, $E_{binding}$ is the binding energy of an electron, and ϕ is the work function which is dependent on the spectrometer used. The XP spectrometer only detects electrons that have escaped into the vacuum of the instrument having originated from approximately 10-12 nm into the surface of the material. Electrons that have escaped from deeper inside the sample are either trapped or recaptured in various excited states within the specimen examined. Each element produces a signature of XPS peaks located at characteristic binding energy values specific to that element. High resolution scans of the peaks can provide information regarding the hybridization, bonding, and functional groups in the sample. XPS is a non-destructive technique to investigate the surface chemistry of inorganic compounds, polymers, metal alloys, or semiconductors. ^[110, 112, 139,140]

In CNT/TiO₂ composites, XPS is typically used to obtain the structure of the nanocomposite ^[141] and the chemical compositions on the surface of the nanotubes. Major peaks due to the carbon 1s and oxygen 1s photoelectrons are observed in the scan. Oxygen/carbon

atomic ratios can be calculated to indicate the extent of surface oxidation. The higher the ratio, the more oxygen atoms are bonded to the nanotubes. ^[142]

In the process of synthesizing TiO₂ composites, other titanium oxide impurities can be created which can enhance or hinder the performance of the composite in the photoanode of a DSSC. While TiO_x can provide extra electrons to the composite, TiO acts as an electron trap consequently lowering the conduction of the material. ^[143,144] The XPS technique can then determine the percentage of TiO on the surface of the composite.

2.1.6 Energy-Dispersive X-Ray Spectroscopy

Energy-dispersive X-ray spectroscopy (EDS) is both a qualitative and quantitative analytical technique used for the elemental analysis of a sample. A beam of electrons is focussed on the sample in either a scanning or transmission electron microscope. The electrons from the primary beam interact with the atoms in the sample, which results in two types of X-rays: Continuous (or background radiation) and Characteristic. Characteristic X-rays allow the identification of individual elements in the sample as well as their concentration, based on the intensity of the rays. An energy dispersive detector receives the rays and displays the resulting signal as a spectrum with respect to the X-ray energy. ^[145, 146]

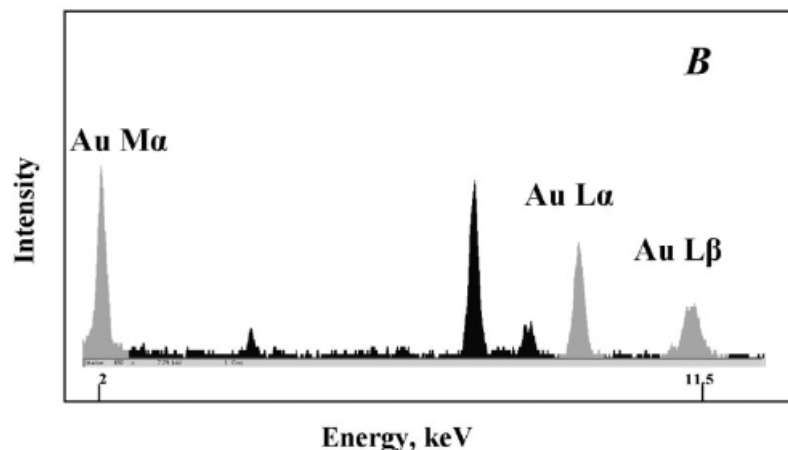

Figure 2-7: Example of an EDS Spectrum of 5.58 at% Au sample. Analysis indicates no detectable impurities since all labeled signals are all due to the presence of gold. (Reproduced with permission from ref [147])

2.3 Other Materials Characterization Techniques

The sections following introduce the basic concepts of other useful characterization techniques that fall under neither the optical nor surface microscopy/spectroscopy categories.

2.3.1 Thermogravimetric Analysis (TGA)

Thermogravimetric analysis (TGA) is an analytical technique in which the mass of a substance is measured as a function of temperature or time. The sample is placed in a controlled environment and the mass is measured as the temperature is increased or decreased at a specified rate. The TGA instrument consists of a sample pan that is supported by a precision balance in a furnace. A purge gas, which can be either inert or reactive, is used to control the environment

and flows through to an exhaust. TGA can determine the liquid content and the presence of volatile species in a sample, the decomposition temperatures of each component, and the rate of thermal degradation.

Combustion of carbon nanotubes typically occurs between 400°C and 640°C. SWNTs with a smaller diameter will combust at lower temperatures due to structural strain. Defects in the nanotube walls will also lower the thermal stability of the sample. Functionalization of CNTs will also alter their thermal stability. Oxidation of CNTs leads to decomposition and reduced thermal stability.^[148] In general, measuring the thermal stability of a CNT sample is a method to determine the quality of the nanotube sample, where higher combustion temperatures are associated with better quality CNTs.^[149]

In the CNT/TiO₂ composite, performing TGA will determine the weight percent of the CNTs in the composite. Similarly, because the TiO₂ film in the photoanode is made of specific percentages of each of its components, TGA can determine the quantity of TiO₂ in the paste making up the film.

2.3.2 X-Ray Diffraction

Powder X-Ray Diffraction (XRD) is one of the main techniques used to characterize solid-state materials. X-ray diffraction patterns provide information with respect to the crystallinity of a material and the average crystallite size. The X-ray diffraction of a crystal is formulated by Bragg's law:

$$2d\sin(\theta) = n\lambda \quad (13)$$

where d is the perpendicular distance between pairs of adjacent planes in the crystal, θ is the incident angle, n is the layer of planes, and λ is the wavelength of the X-rays. The distance between adjacent planes can be expressed by cell parameters and the Miller index:

$$\frac{1}{d^2} = \frac{h^2}{a^2} + \frac{k^2}{b^2} + \frac{l^2}{c^2} \quad (14)$$

where a , b , and c are the sides of the unit cell; and h , k , and l are the Miller indices which describe the lattice planes in the crystal.

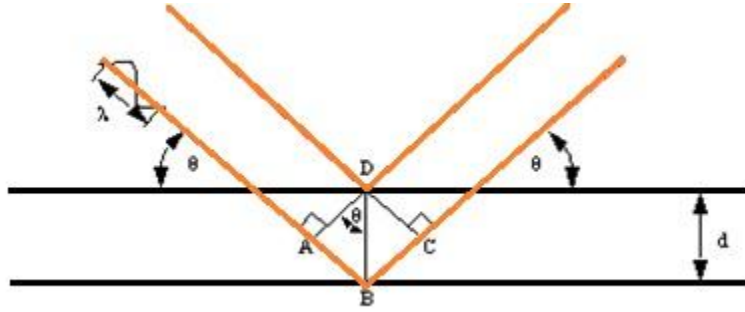

Figure 2-8: Schematic of Bragg's Law of Diffraction

In this study XRD is used to characterize TiO_2 and TiO_2 composites. The anatase phase of TiO_2 (101) and the rutile phase (110) are used to determine the average size of the nanocrystallites using Scherrer's equation: ^[150-152]

$$D_{crys} = \frac{0.9\lambda}{\beta \cos\theta} \quad (15)$$

where D_{crys} is the average nanocrystallite size (nm), λ is the wavelength of the X-ray (1.542 Å), β is the full width at half maximum intensity, and θ is half of the diffraction peak angle.

2.3.3 Brunauer-Emmett-Teller Analysis (BET)

Brunauer-Emmett-Teller (BET) theory aims to explain the physical adsorption of gas molecules on a solid surface and is a method for determining the specific surface area of a material. When a solid is exposed to a gas or vapour in a closed space at a definite pressure, the solid begins to adsorb the gas. The adsorption of the gas on the surface of the solid is used to determine the specific surface area of the material by calculating the amount of adsorbate gas corresponding to a monomolecular layer on the surface.^[154] Physical adsorption results from van der Waals forces between the adsorbed gas molecules and the adsorbant surface. The amount of adsorbed gas is typically carried out at the temperature of liquid nitrogen and measured by a volumetric or continuous flow procedure. Using BET theory, the surface area is calculated from the amount of monolayer gas molecules required to cover the solid surface and the cross-sectional area of the gas molecule being adsorbed. The BET equation is written as:

$$\frac{P}{v(P_0-P)} = \left(\frac{c-1}{cv_m}\right) \frac{P}{P_0} + \frac{1}{v_m} \quad (16)$$

where P and P_0 are equilibrium and saturation pressures of the adsorbed species, v is the amount of adsorbed gas, v_m is the amount of gas adsorbed as the monolayer, and c is the BET constant. The BET equation illustrates an adsorption isotherm as a straight line where $P/v(P_0-P)$ is plotted

on the y-axis and P/P_0 is on the x-axis. With the equation written in this way, it is clear that the slope is $\frac{c-1}{cv_m}$ and v_m^{-1} is the y-intercept. The slope and y-intercept are used to calculate the amount of monolayer gas, v_m , and the BET constant c . The BET constant, which is dependent on temperature, is calculated by:

$$c = \exp\left(\frac{E_1 - E_L}{RT}\right) \quad (17)$$

where T is the temperature, R is Boltzmann's constant, E_1 is the heat of adsorption of the first layer, and E_L is the heat for liquefaction.^[155] The total surface area and specific surface area can be calculated by:

$$S_{total} = \frac{v_m \cdot N \cdot A_x}{M} \quad (18)$$

$$S_{sp} = \frac{S_{total}}{m} \quad (19)$$

where S_{total} is the total surface area, N is Avogadro's number, s is the adsorption cross section, M is the molecular weight of the adsorbed species, S_{sp} is the specific surface area, and m is the mass of the sample analyzed.^[156]

Since the surface area and porosity of the TiO_2 affects the amount of dye coating and electron transport as well as the introduction of shunt paths to the cathode, BET analysis was done to the hydrothermally synthesized TiO_2 to determine these parameters. This was required to decide if thermal treatments of the TiO_2 powder caused a large decrease to the particle size.

2.4 Photovoltaic Characterization

The quantum efficiency and current-voltage measurements are the basic characteristics of a solar cell. These techniques are performed under a solar simulator with a radiation intensity of 100 mW/cm^2 , or 1 sun, and are measured with respect to a standard reference irradiance distribution: the air mass 1.5 global, or AM 1.5G.

2.4.1 Quantum Efficiency (IPCE)

The current generated at short circuit by a solar cell is dependent on the energy of the incident light. The quantum efficiency (QE) describes the relationship between the incident light and the short-circuit current (I_{sc}). By definition the quantum efficiency is the probability that an incident photon, with an energy E , will excite an electron to the external circuit. The short-circuit current is given by:

$$I_{sc} = q \int b_s(E)QE(E)dE \quad (20)$$

where $b_s(E)$ is the photon flux density of the incident light and q is the electronic charge. The external quantum efficiency is also called the incident photon-to-current conversion efficiency, or IPCE. In simple terms, the IPCE is a dimensionless quantity which represents the ratio between the amount of electrons generated and the amount of photons incident on the solar cell.

[157]

2.4.2 Current-Voltage Measurements (I-V Measurements)

The key performance parameters of a solar cell are determined from the current versus the applied voltage (I-V) characteristics under illumination. When the cell is illuminated, a photocurrent (I_{ph}) is generated. When there is no illumination and a forward voltage bias is applied, a dark current (I_{dark}), flows in the opposite direction. Charge recombination in the photoactive layer induces a shunting current (I_{shunt}) which gives rise to a shunt resistance (R_{shunt}). The series resistance of the cell is a summation of the contact resistance at the interfaces, bulk resistance, and the sheet resistance of the electrodes.

By analyzing the I-V curve under illumination (see Figure 2-9), the short-circuit current (I_{sc}) can be extracted when $V = 0$ and similarly the open-circuit voltage (V_{oc}) can be found when $I = 0$. The maximum power point can be found on the curve where the $P_{max} = I_{MP}V_{MP}$. This point defines the condition in which the power output of the device is at its maximum. Conventionally, the solar to electric power conversion efficiency, which is the key parameter of a solar cell, is described in terms of V_{oc} and I_{sc} which requires the introduction of a dimensionless parameter called the fill factor (FF):

$$FF = \frac{V_{MP}I_{MP}}{V_{oc}I_{sc}} \quad (21)$$

A decrease in the shunt resistance reduces the open-circuit voltage as well as the fill factor. Alternatively an increase in series resistance results in a decrease in the fill factor and the short-circuit current. It is the goal for any solar cell to have the lowest possible series resistance

to avoid loss of current. The values for both the series and shunt resistance can be found from the slopes of the IV curve at V_{oc} and I_{sc} respectively. [157, 158]

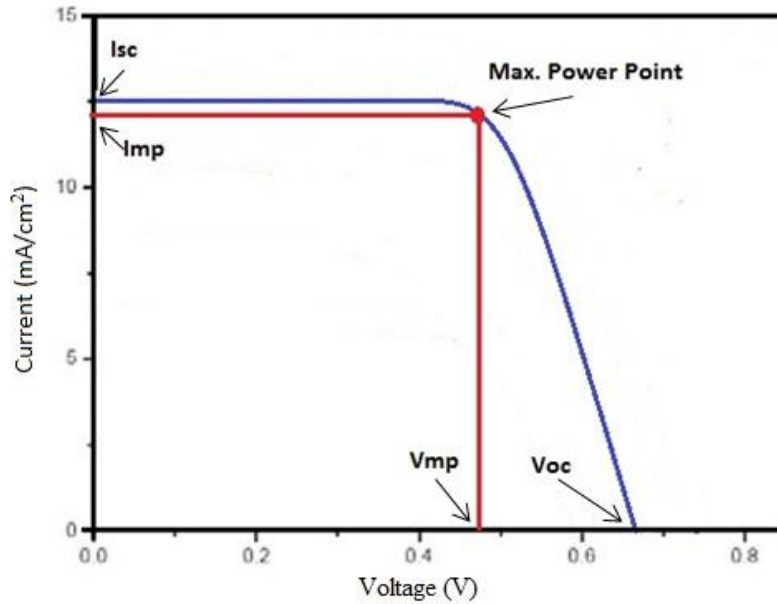

Figure 2-9: Example I-V Curve labelling the maximum power point (MPP) and its associated voltage and current (V_{mp} , I_{mp}), the open-circuit voltage (V_{oc}), and the short-circuit current (I_{sc}).

The last parameter measured from the IV curve under illumination is the energy conversion efficiency which is described by the ratio of the maximum extractable power to the incident solar power (P_{in}). It is quantitatively expressed as:

$$\eta = \frac{P_{max}}{P_{in}} = \frac{V_{MPP}I_{MPP}}{P_{in}} = \frac{FFI_{sc}V_{oc}}{P_{in}} \quad (22)$$

Two main parameters are derived from the curves generated under dark current. The first is the saturation dark current (I_0) which is a measure of the recombination in the cell. A cell with

a large amount of recombination will have a large I_0 value. For an ideal diode, the dark current density is expressed as:

$$I_{dark}(V) = I_0(e^{qV/Tk_B} - 1) \quad (23)$$

where I_0 is the saturation dark current, q is the elementary charge constant, V is the voltage, T is the temperature, and k_B is the Boltzmann constant. The saturation dark current is empirically found by taking the \ln of the current. Plotting this versus the voltage gives us the linear relationship:

$$\ln(I) = \frac{qV}{k_B T} + \ln(I_0) \quad (24)$$

where $\ln(I_0)$ is the y-intercept.

The last parameter taken from the dark I-V curve is the ideality factor (m) which measures how well the device behaves like a diode. A PV device has an ideality factor between 1 and 2; however values higher than 2 are possible due to the presence of non-linearity or a high (ohmic) contact resistance at the metal-semiconductor junction. The ideality factor is calculated from the dark saturation current by taking the diode equation including the ideality factor and again plotting the $\ln(I_{dark})$ versus the voltage:

$$I_{dark}(V) = I_0(e^{qV/mTk_B} - 1) \quad (25)$$

$$\ln(I) = \frac{qV}{mk_B T} + \ln(I_0) \quad (26)$$

The ideality factor can be found by taking a linear fit, finding the slope, and rearranging the slope parameter for m .

Chapter 3

EXPERIMENTAL

3.1 Carbon Nanotube Growth and Preparation

In this study carbon nanotubes produced using high-pressure carbon dioxide (HiPCO) were purchased from Nanointegris. Additionally, samples of carbon nanotubes were grown “in-house” using the chemical vapour deposition method described in the following section. Both of these samples of CNTs were phase separated to remove iron impurities and prepared into an aqueous suspension for gel filtration.

3.1.1 Chemical Vapour Deposition of Carbon Nanotubes

The CNTs were grown via chemical vapour deposition (CVD) using a Barnstead tube furnace, a 121.92 cm long quartz tube with a 5 cm diameter, and a heating coil. A flow meter used to control air flow out of a nitrogen gas cylinder, and a bubbler was arranged with respect to the CVD system, as shown in Figure 3-1. The right end of the heating coil (heated from the variac), was placed 10 cm from the right edge of the tube and over the mixture of camphor and ferrocene. This ensured that the mixture remained inside the tube; but away from the furnace. The left end of the tube was placed 50 cm away from the center of the furnace with the right end about 71cm away. The nitrogen gas cylinder was connected to the tube on the right side, via a

floating ball flow meter. The left side of the tube was connected to the exhaust, via a bubbler, resulting in a flow of air and carbon material from right to left.

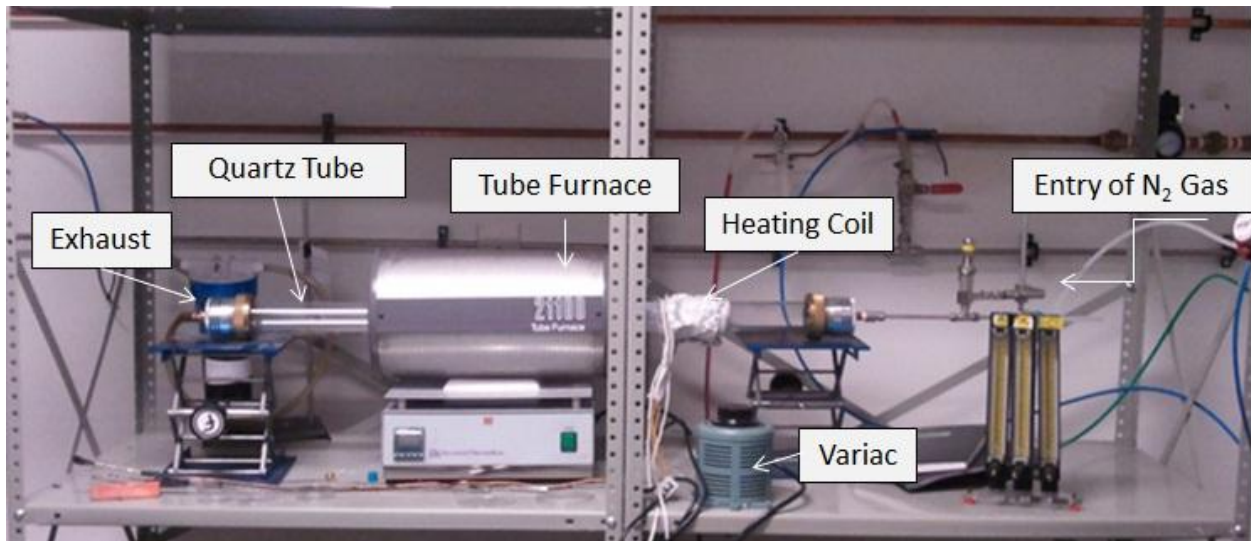
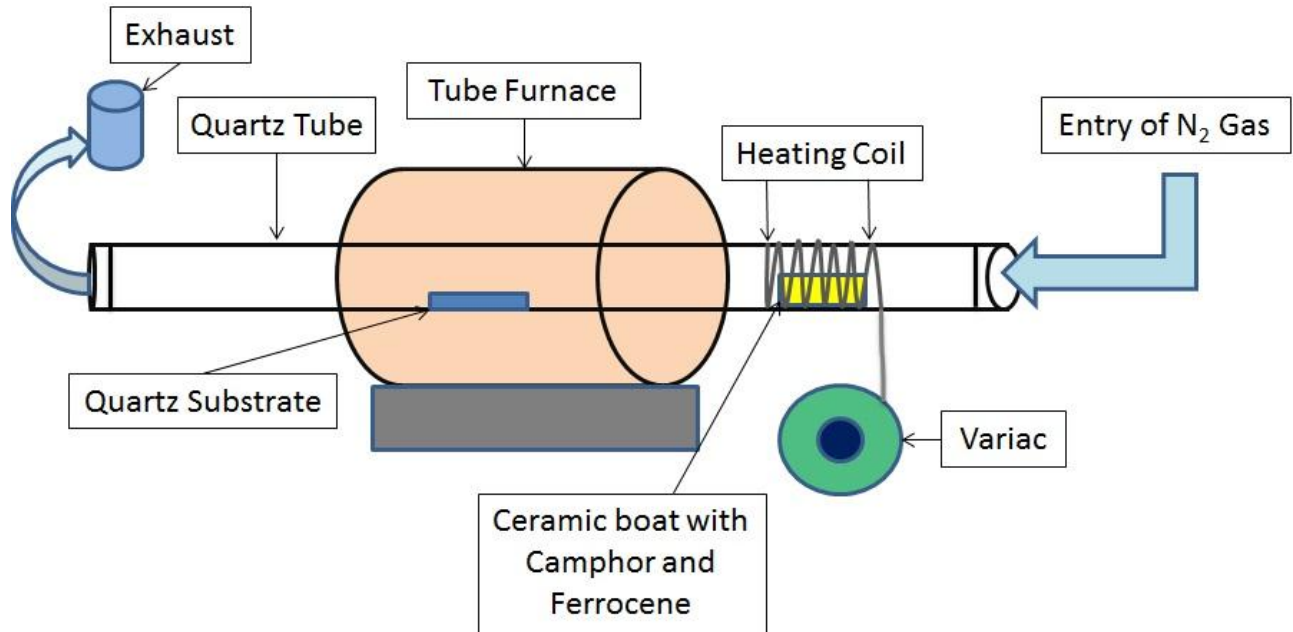

Figure 3-1: Chemical Vapour Deposition Schematic (top) and Picture (bottom) for the Growth of Carbon Nanotubes

The “hot zone” was controlled by both the variac on the right end of the tube and a microcontroller in the furnace. The microcontroller was programmed to dwell at a set temperature while the variac was slowly increased during the first 10 to 12 minutes of dwell time. The temperature of the heating coil was measured with an IR probe that was connected to a digital temperature meter. The CNTs growth was observed primarily in the area covered by the furnace, with minimal growth occurring outside of the furnace.

Approximately 3 grams of camphor and 2% wt. of ferrocene were each loaded into opposite sides of a ceramic boat which was then inserted approximately 10 cm into the right side of the (clean) quartz tube, and subsequently covered with a heating coil. The furnace was positioned as explained previously with the flanges secured. The tube was then purged with nitrogen gas for 20 minutes before readjusting the gas flow to the furnace to establish a rate temperature rise of 10 °C per minute to a maximum value of 800 °C.

3.1.2 Preparation of Carbon Nanotubes Grown by Chemical Vapour Deposition (CVD) and High-Pressure Carbon Monoxide (HiPCO)

Raw CNTs were treated using the organic aqueous phase separation procedure outlined in Tvrđy *et al.*^[159] One gram of raw CNTs, prepared by either high pressure carbon monoxide (Nanointegris), or chemical vapour deposition (UOIT), was placed into a beaker with ~ 20 mL of deionized water. The mixture was then sonicated for 5 minutes in a bath sonicator, and then transferred into a separation funnel. A small amount of hexane was added and the mixture was shaken to produce a phase separation. The procedure was repeated with the addition of small amounts of hexane, followed by shaking the funnel to ensure there were no CNTs left in the

aqueous phase. Periodically the stopcock of the funnel was adjusted to release gas building up in the funnel. After several iterations, the aqueous phase turned a yellow colour due to the presence of impurities from the CNT growth process. The aqueous phase was then removed by draining the fluid into a beaker placed beneath. The organic phase (a mixture of hexanes and purified SWNTs), was allowed to flow into a round-bottom flask. The flask was then placed in a rotary evaporator, under normal vacuum, which in turn was placed inside an oven for approximately 6 hours.

3.1.3 Preparation of an Aqueous Suspension of Carbon Nanotubes

A CNT suspension was created at a rate of 1 mg/mL in an aqueous solution of 2% wt. sodium dodecyl sulphate (SDS, 99%, Sigma Aldrich). The mixture was first placed in an ultrasonic bath for 5 min to break up the large pieces of CNTs before being placed under a tip sonicator (Sonifire 450D, Branson) with a 0.5 inch flat tip at 20 W cm^{-2} for 20 hours. Before sonication, the tip was set 1 cm away from the bottom of the beaker and placed in a temperature-controlled bath at approximately $10 \text{ }^{\circ}\text{C}$.

Immediately following tip sonication the sample was ultracentrifuged at 197,000g for 15 minutes at $10 \text{ }^{\circ}\text{C}$. The top 90% of the supernatant was removed from each ultracentrifuge tube and directly poured into the gel column described in the section below.

3.2 Separation by Chirality: Size-Exclusion Gel Chromatography

Filtration and chirality separation was done in two phases by using the gel chromatographic method outlined by Liu *et al.*^[106] The original method was modified to a single pass to increase the yield and concentration of SWNTs purified for PV application.

3.2.1 General Procedure

The general procedure, introduced and outlined by Liu *et al.*^[106], is a two-pass process where chirality separation was performed using the “SS-MUGEC” method. In this method a number of 10 mL syringes were connected vertically in series and filled with 1.4 mL of allyl dextran-based size-exclusion gel beads (Sephacryl S-200 HR or S-300 HR, GE Healthcare). An illustration of the separation process is presented in Figure 3-2. After the columns were equilibrated with a 2 wt% SDS solution, 5-10 mL of SWNTs, held in an aqueous suspension and ultracentrifuged, were added to the top column. After the SWNT solution had gone through the column, the column was then taken apart and 6 mL of a 2 wt% SDS aqueous solution was added to each syringe to elute the unbound nanotubes. The semiconducting tubes that were trapped inside the gel were eluted with 4 mL of a 5 wt% SDS solution.

In order to separate the majority of the semiconducting tubes from the metallic ones, the column was equilibrated with 2 wt% SDS solution. After the column was equilibrated, the procedure was repeated by loading the unbound tubes into the column until there were no more semiconducting tubes trapped in the gel leaving only highly enriched metallic tubes.

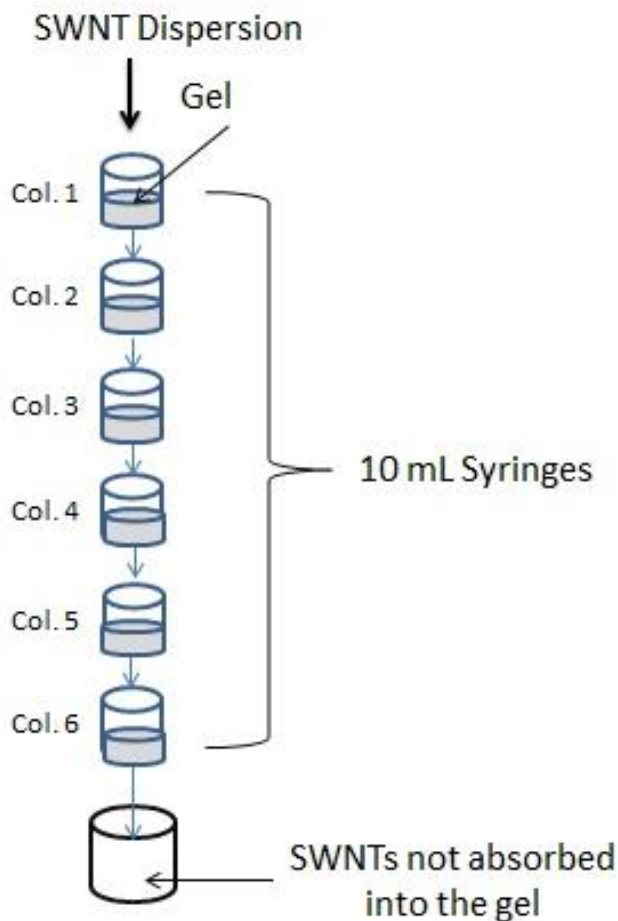

Figure 3-2: Schematic of Separation Process

In order to get an enriched single chirality, a second pass of the previously filtered tubes was required. Prior to secondary separation, each of the samples were diluted to a 2 wt% SDS solution. Again, a number of 10 mL syringes were arranged vertically in a series and equilibrated. The diluted semiconducting fractions were then added to the top column and allowed to flow through the syringes. The column was then disassembled and the unbound tubes eluted with a 2 wt% SDS solution. The semiconducting tubes that were absorbed into the gel were eluted by inserting 4 mL of 5 wt% SDS solution. The result was a solution with an enriched single chirality.

3.2.2 Modified Procedure: Obtain a Single Chirality in a Single Pass

One disadvantage to requiring two passes through the column is a reduction in CNT concentration following each pass. As the separated CNTs are to be used in a DSSC, it was necessary to obtain as much of the enriched-chirality CNTs in one pass as possible. In our study, we modified the original procedure to maximize the collection of enriched single-chirality in a single pass.

Similar to the original procedure, a number of syringes were vertically arranged in series and plugged with glass wool. The number of syringes arranged depended on the chirality we were targeting to separate from the rest. 1-2 mL of gel was injected into each syringe and equilibrated with 10 mL of 2 wt% of SDS solution. Unbound tubes were eluted with 1.8 wt% SDS solution.



Figure 3-3: Photo of Modified Separation Process

This study examined chiralities (6,5) and (7,3). It was determined that in order to separate the desired chiralities in a single pass, different ratios of gel/SWNTs were required. By injecting 11 mL of SWNT/SDS solution into 1.4 mL of gel/column, into the top column of a 4 column stack, the separation of highly enriched (6,5) in the fourth column occurred. To separate enriched (7,3), 17 mL of SWNT/SDS solution was injected into the top column with 1.4 mL of gel in each syringe. The (7,3) chirality eluted in the first three columns; however the first column yielded the least impurities.

3.3 Hydrothermally Synthesized TiO₂ and TiO₂/SWCNT Composite

Two mL of titanium isopropoxide (>97%, Aldrich) was hydrolyzed by adding 6 μ L of deionized water. When synthesizing only TiO₂, the solution was immediately transferred to a Teflon-lined acid digestion vessel (45 mL, Parr Instrument) along with 3 mL of 1M H₂SO₄ (95-98%, Sigma-Aldrich). The vessel was then covered and sealed before placing it into a muffle furnace for 24 hours at a temperature of 175 °C. When preparing the TiO₂/SWNT composite, 3 mg of phase-separated CNTs were added to the solution, and then sonicated in a bath sonicator for 5 minutes. Following sonication the solution was transferred to the vessel with 3 mL of 1M H₂SO₄ and then placed in a muffle furnace at 175 °C for 24 hours. For both the TiO₂ and TiO₂ composite, the autoclave was removed from the muffle furnace and left to cool for 2 hours. The autoclave was then opened and the CNT/TiO₂ composite placed in a beaker of deionized water to precipitate. Deionized water was drained out of the beaker and re-filled with fresh deionized water three times before filtering through a Whatmann paper filter (Grade 1, 15 mm, Sigma-

Aldrich) and left to dry. Once dry, the powder was then ground with a mortar and pestle and stored in a dry place. ^[160]

3.4 Dye-Sensitized Solar Cell Fabrication and Assembly

The DSSCs were fabricated using glass purchased with one side coated in fluorine doped tin oxide. The glasses were cleaned using the standard RCA cleaning procedure and those that were to be used as the photoanode were treated with TiCl_4 . The anode was prepared following three different procedures: the first involved screen printing the TiO_2 paste onto one of the treated FTO glasses. The second method screen printed the paste made from the CNT/ TiO_2 composite onto the treated FTO glass. The third procedure required creating a CNT film (mixed or chirality-specific), then depositing it onto the FTO glass and screen printing the TiO_2 paste on top of the film. The cathode was then prepared and both electrodes sandwiched together and sealed.

3.4.1 Cleaning and Treatment of FTO Glasses

The RCA-1 and RCA-2 cleaning procedures ^[161] were used to decontaminate the FTO glasses of organic residue and metal ions. These procedures were developed by Werner Kern at RCA laboratories in the late 1960's and are now considered standard procedures for cleaning silicon wafers. Both processes consist of sequential oxidative desorption and complexing with $\text{H}_2\text{O}_2\text{-NH}_4\text{OH-H}_2\text{O}$ in the RCA-1 procedure and with $\text{H}_2\text{O}_2\text{-HCl-H}_2\text{O}$ in the RCA-2 procedure. The procedures leave the FTO glass with a thin oxide on the surface. Following RCA-1 and

RCA-2 cleaning, the FTO glasses were treated with 40 mM of TiCl_4 . The procedures of both cleaning methods and TiCl_4 treatment are outlined below.

(i) RCA-1

This method was used to decontaminate the FTO glass from organic residues and films. Five parts water (H_2O) and 1 part ammonium hydroxide (NH_4OH) were added to a Pyrex beaker and then heated to 70 ± 5 °C. Once the solution reached the desired the temperature, the beaker was removed from the hot plate and 1 part 30% hydrogen peroxide (H_2O_2) was added. After 1-2 minutes the solution began to bubble vigorously indicating it was ready for use. The FTO glasses were then inserted into the bubbling solution and soaked for 15 minutes after which they were removed and placed into a fresh beaker filled with deionized water. The beaker was then placed under flowing deionized water for a couple of water changes to keep organic residue from re-depositing onto the surface of the FTO glass. The RCA-1 solution was then diluted with cold water and left to cool at the back of the fumehood before disposal.

(ii) RCA-2

This method was utilized to decontaminate metal ions from the surface of the FTO glass. In this procedure 6 parts of deionized water (H_2O) was mixed with 1 part hydrochloric acid (HCl) in a Pyrex beaker and heated to 70 ± 5 °C on a hot-plate. Once the desired temperature was reached, the beaker was removed from the hot plate and 1 part hydrogen peroxide (H_2O_2 , 30%) was added. After 1-2 minutes the solution began to bubble indicating it was ready for use.

The FTO glasses were inserted into the beaker and left to soak for 10 minutes. When finished, the glasses were removed and rinsed with deionized water. The RCA-2 solution was left to cool and then poured into a waste container.

(iii) Titanium Tetrachloride (TiCl₄) Treatment

This treatment was utilized to improve the adhesion of the TiO₂ film to the FTO glass and to act as a blocking layer. The procedure required 4 mL of TiCl₄ to be added and stirred in a beaker with 100 mL of deionized water. The solution was then heated to 70 ± 5 °C (any more than this and the TiCl₄ hydrolyzes) and the glasses were left to soak at a constant temperature of 70 °C for 30 minutes. When finished the glasses were removed, washed with deionized water, then washed with ethanol, and then finally blow dried with compressed air. The thin film should be mildly visible when the glass is inspected under light.

3.4.2 Preparation of the Photoanode

(i) SWNT Thin-Film

The films prepared in this work were deposited using a vacuum filtration method: cellulose nitrate membranes with a pore size of 0.2 μm and diameter of 25 mm were used to filter the SWNTs from the surfactant solution. The membranes were clamped to a glass frit and (with the vacuum on) washed with 30 mL of deionized water. The SWNT solution obtained

from the chromatography process was diluted with deionized water to a 1 wt% SDS solution. This decreases the concentration of SDS and SWNTs to help create a more uniform film. The now diluted SWNT/SDS solution was filtrated through the vacuum filtration apparatus. A thin film of CNTs accumulated on the filter surface as the solution passed through the cellulose nitrate membrane. Once all of the solution passed through, the vacuum was left on, and the film was allowed to sit for 15 minutes to set the CNT film. Once the film was dry and set, 1 mL of isopropanol was passed through the filter. The isopropanol decreases surface tension and lowers the likelihood of cracks forming in the film. Approximately 30 mL of deionized water was then passed through the film to wash any remaining SDS in the membrane. After rinsing, the film was allowed to set again by sitting under vacuum for another 15 minutes.

The film was then transferred to the FTO glass by a method originally introduced by Wu *et al.*^[162] First the film was dipped in ethanol and then, applying gentle pressure, the film was pressed (film side down) against the conductive side of the glass. In the original method, outlined by Wu *et al.*, the substrate and film were placed, film side up, into a stirred bath of liquid acetone. However, when this was attempted it was found that the adhesion between the cellulose nitrate filter and the CNT film was larger than that of the film and the substrate. As a result, the film failed to be kept intact as the filter dissolved and it became evident that a gentler method was needed to digest the filter. The subsequent method used was mentioned in Wu *et al.*, where the substrate was placed into an acetone vapour bath instead.

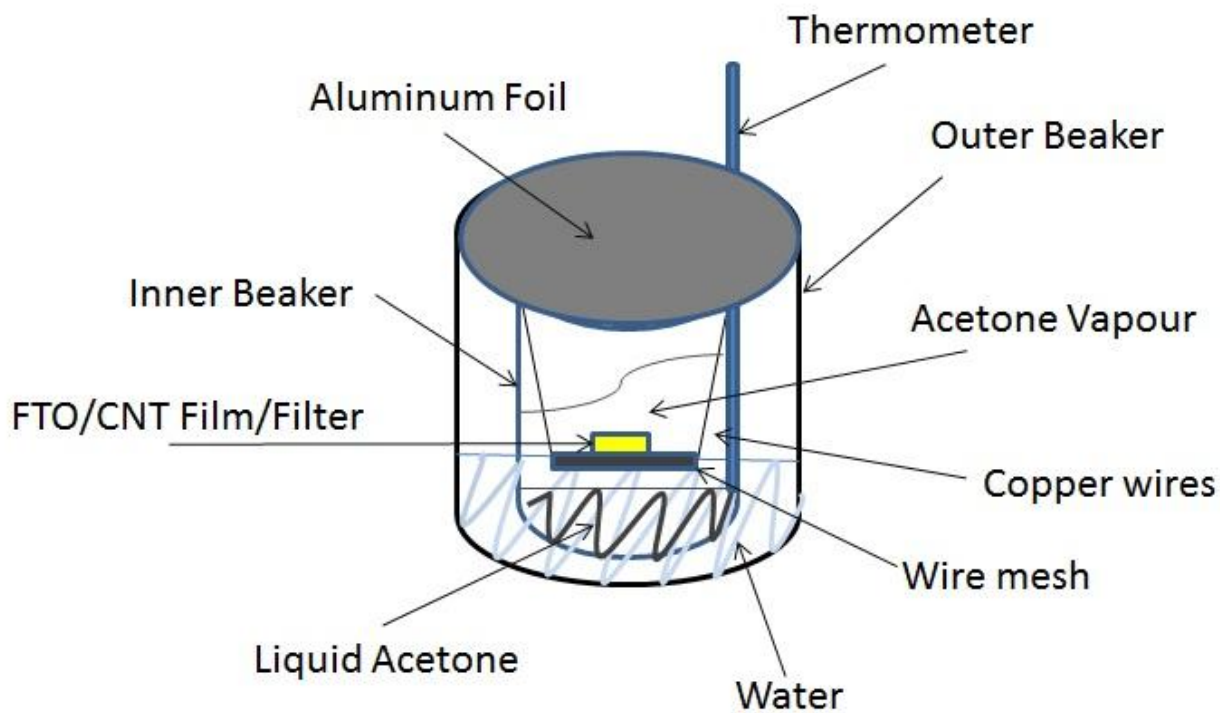

Figure 3-4: Schematic (top) and Photo (bottom) of an Acetone Vapour Bath in a Double Boiler System

In this study, a modified version was performed by creating a double boiler to slowly increase the temperature of the acetone and maintain it at its boiling point. The FTO glass and filter was lowered into the acetone vapour (filter side up) until it was about 2 inches from the liquid. Aluminum foil was used to cover the beaker and to keep the vapour from evaporating. The acetone vapours were allowed to gradually dissolve the cellulose nitrate filter. The filter and substrate were allowed to sit in the vapour bath for approximately an hour and a half to ensure the entire filter was visibly dissolved. The filter was then placed into a stirred bath of liquid acetone for 15 minutes to remove any remaining cellulose nitrate residue. It is important to make sure the entire filter was visibly digested prior to putting the substrate into the liquid bath, as placing the substrate into the bath too soon will result in the thin film breaking apart. Following the liquid acetone bath, the glass was placed into a stirred bath of ethanol for 15 minutes, then removed to dry. After the film dried on the substrate, it was baked for 2 hours at 250 °C in a muffle furnace. The purpose of this last step was to reduce the sheet resistance of the film.

(ii) TiO₂ and TiO₂/SWNT Composite Paste

The first part of the investigation of DSSC performance compared the CNT/TiO₂ composite prepared by hydrothermal synthesis with the TiO₂ composite produced by the same method without CNTs. The hydrothermal procedure is outlined in section 2.3 of this document.

The original mixing procedure to produce TiO₂ paste for the photoanode was introduced by Ito *et al.* ^[164] and was modified in this work to increase the ratio of TiO₂ to decrease delamination during heat treatments. The increased ratio of TiO₂ resulted in a thicker paste

required only 3-4 layers of screen printing to achieve a film thickness of 15 μm . The paste was made using the procedure outlined in Figure 3-5.

The paste for the TiO_2 photoanode in the chirality specific experiments was made using Aeroxide TiO_2 P90, instead of the hydrothermally synthesized TiO_2 . The paste was produced using the same procedure as the composite paste.

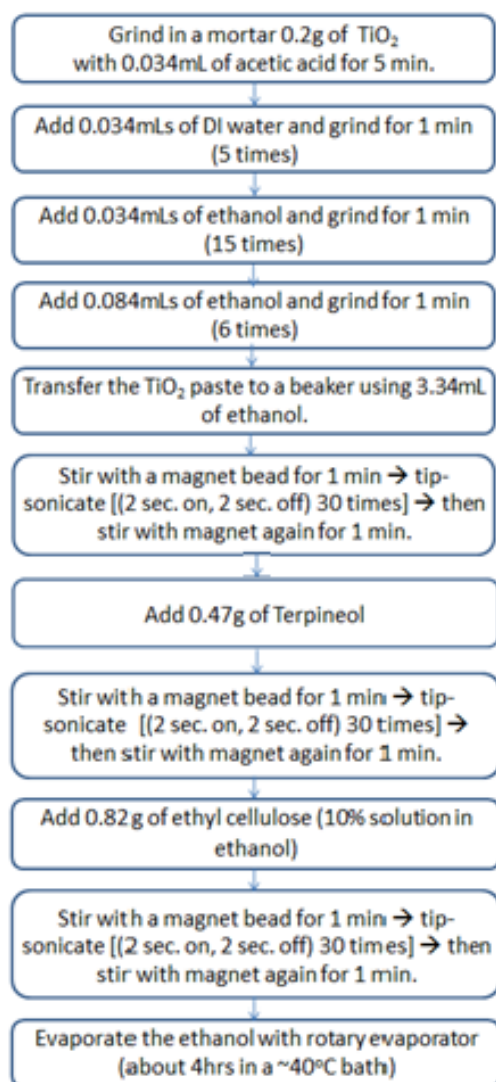

Figure 3-5: Modified procedure for anode paste preparation

(iii) Final Preparation Steps

The majority of anodes were prepared by screen printing the TiO_2 paste over the thin film composed of filtered SWNTs onto the FTO glass.^[164] For comparison, one anode was prepared with the TiO_2 paste screen-printed without a filtered SWNT film underneath, and another prepared with the TiO_2/SWNT paste also without the presence of a filtered SWNT thin film. The screen-printing apparatus is shown in Figure 3-6.

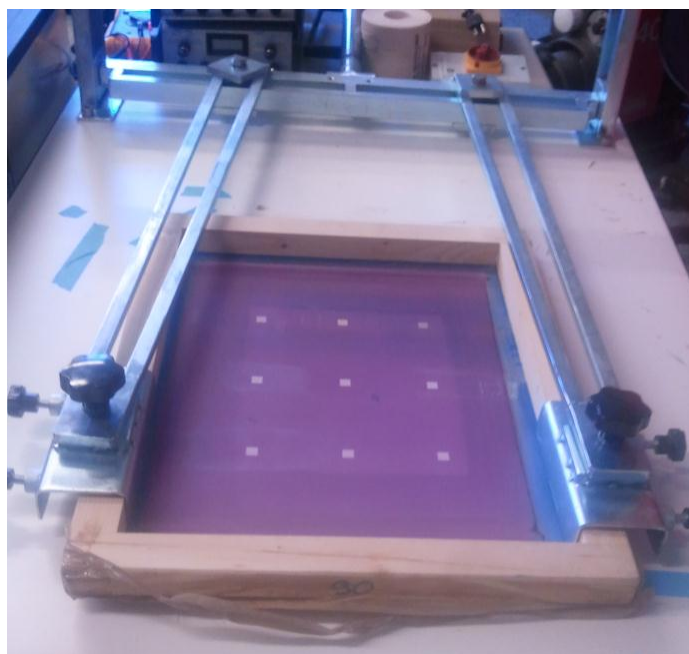

Figure 3-6: Screen-printing mesh to produce TiO_2 films

FTO glass was placed under a 1 cm^2 square mesh and the paste was spread across the mesh, using a fill blade, leaving a film on the FTO glass. After each layer was printed, the film was allowed to settle on top of a sponge soaked with ethanol until the film visibly relaxed (when the ripples of the film flattened). The first layer relaxed almost immediately and each subsequent

layer took a little longer following each printing. The film was then dried on a hotplate for 5 minutes at 125 °C before the next layer was applied. To get the desired 15 µm thickness, only 3-4 layers were printed before annealing the film. If the anode being prepared had a film of filtered SWNTs underneath a TiO₂ film, then the exposed parts of the SWNT film were scratched with glass taking care not to scratch off any of the FTO. Annealing the film was done in stages: 325 °C for 5 minutes in air, 350 °C for 5 minutes in air, 350 °C for 5 minutes under nitrogen, 450 °C for 15 minutes under nitrogen, and then finally 500 °C for 15 minutes also under nitrogen. The furnace temperature was ramped up under air at a rate of 5 °C/min to limit temperature overshooting and then under nitrogen after 350 °C to avoid combustion of the SWNT films. Following the first heat treatment, the glasses were again soaked in a TiCl₄ solution at 70 °C for 30 minutes and then rinsed with deionized water and ethanol. Once dry, the films underwent another heat treatment at 350 °C in air for 30 minutes, and then increased to 500 °C under nitrogen for another 30 minutes. When the films cooled to between 70 – 80 °C, they were immediately placed into a bath of 5 mM N-719 dye solution, sealed, and stored in a dark place for 24 hours. When the glasses were removed from the dye, the films were then rinsed with acetonitrile and ready for cell assembly.

3.4.3 Preparation of Cathode

Two holes, approximately 0.5 mm in diameter, were drilled into the FTO glass slides about 1.5 cm apart. The glasses were cleaned using the RCA-1 and RCA-2 procedures outlined in section 3.4.1. Using scotch tape, an area of 1 cm² was masked out on the glass (so that it lined

up with the film on the anode) and platinized with 5 layers of Platisol T paint (Solaronix). The platinum electrode was then treated in air at 450 °C for 15 minutes.

3.4.4 Final Assembly of DSSCs

The DSSC was assembled by sandwiching the photoanode and counter-electrode together using a 25 µm Meltonix gasket (Solaronix) to seal the cell together and to keep the two electrodes from touching. A T shape was cut in the center of the gasket with the stem 1 cm² (which lines up with the film) and the sides large enough to go over the holes. This is illustrated in Figure 3-7. When the electrolyte is injected into one of the holes of the counter-electrode, the electrolyte will travel across the film to the other hole.

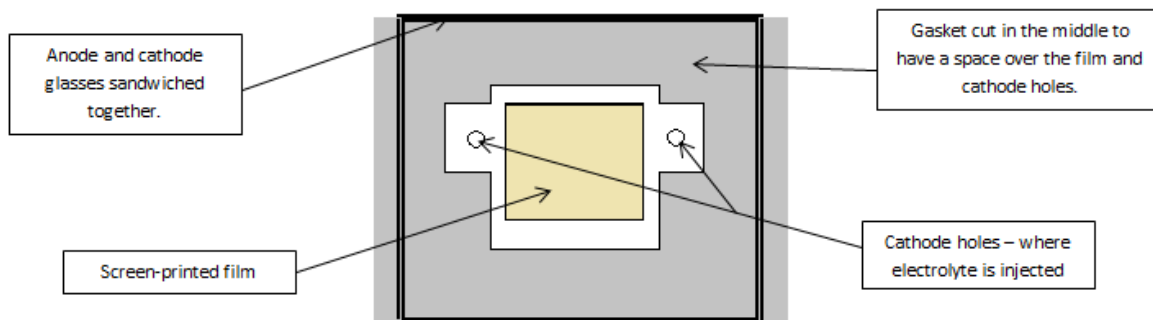

Figure 3-7: Looking down on the cell from the photoanode side

When cutting the gasket to fit the cell, it was ensured that some slack was left on either side of the glasses to ensure that it sufficiently filled the space in between the electrodes. The

glasses were clamped together and placed in an oven at 120 °C for 20 minutes. When the cell is removed from the oven, the gasket should be completely transparent and without bubbles.

The electrolyte was injected into the cell via one of the drilled holes in the cathode. The electrolyte was pulled through the cell, across the film, to the other hole before injecting more electrolyte into the other hole. To seal the electrolyte in the cell, the holes of the cathode were covered with a 60 µm Meltonix gasket (Solaronix) and pieces of thin glass microscope slide were cut and soldered onto the glass. Using an ultrasonic soldering iron, the copper wire contacts were made using a Cerasolzer soldering alloy which specifically adheres to glass.

3.5 Characterization Methods

Experimental procedures for optical, surface characterization and other materials characterization experiments are described in the sections below. Description of how the DSSC cells were characterized using IPCE curves and current-voltage curves under both dark and illumination are also included.

3.5.1 Optical Spectroscopy Techniques

UV-vis-NIR Spectroscopy

CNT solutions were analyzed using a Perkin Elmer Lambda 750S UV-vis Spectrometer with a 60 mm Integrating Sphere with wavelengths ranging from 200 nm to 1350 nm. The UV-

Vis resolution of the instrument was from 0.17 to 5.00 nm and the resolution of the NIR ranged from 0.20 to 20.0 nm.

Photoluminescence Excitation (PLE) Spectroscopy

PLE spectra were obtained with a Jobin-Yvon SPEX Fluorolog 3.22, equipped with 450 W Xe lamp and an InGaAs detector using a 10 mm quartz cuvette. Slit widths for both excitation and emission were set to a 10 nm band-pass, and correction factor files were applied to account for instrument variations. Photoluminescence maps were obtained at 25°C, with 5 nm intervals in both excitation and emission.

FTIR Spectroscopy

IR spectroscopy was done using a Perkin Elmer Spectrum 100 with a Horizontal Attenuated Total Reflectance (HATR) accessory. The sample was spread over the ZnSe crystal and pressed with the force arm attached. Spectra were collected from 400 cm^{-1} to 4000 cm^{-1} in 10 accumulations using a resolution of 4 cm^{-1} .

Raman Spectroscopy

Raman Spectra were acquired with a Renishaw Raman microscope using an argon laser with a 514 nm wavelength. Sample preparation required dispersing approximately 5 mg of

CNTs into 100 μL of isopropanol. The mixture was placed into a bath sonicator for about 5 minutes to make a dark solution. A drop of the mixture was then placed on a silicon wafer and left to dry for 30 minutes. The microscope was focussed and the spectra were collected at 20 accumulations, with an objective lens setting of 50x, and from 100 nm to 4000 nm.

3.5.2 Surface Characterization

Scanning Electron Microscopy (SEM)

A small amount of CNT sample was placed on a stage and placed in a JEOL 6400 SEM. Once loaded, three or four images were taken of each sample at varying magnifications and accelerating voltages.

Field-Emission Scanning Electron Microscopy (FE-SEM)

The TiO_2 and TiO_2/CNT composites were characterized using a ZEISS SUPRA 40 Field-Emission Scanning Electron Microscope equipped with a lanthanum boride electron gun. The equipment generates images with a nominal resolution of 1.5 nm at 10 KV and a WD of 2 mm. The composites were first metallized by sputtering chromium, and then placed in the chamber. Images were taken at varying magnifications. The FESEM is equipped with an energy-dispersive X-rays detector.

X-Ray Photoelectron Spectroscopy

XPS experiments were conducted using a Perkin-Elmer, Optica 3100 XL and carried out with a Leybold-Heraeus LHS10 spectrometer using Al K α (1486.6 eV) radiation. Samples were deposited on a gold sheet and were analyzed in the chamber at a residual pressure of 10^{-9} Torr.

3.5.3 Other Materials Characterization Techniques

Thermal Gravimetric Analysis (TGA)

TGA analysis was accomplished using a Q Series SDT Q600 Model (TA Instruments) by oxidizing the samples in air, with a flow rate of 50 mL/min. Samples of approximately 3 mg were gradually heated from 30 °C to 1000 °C at a rate of 5 °C/min. The samples were placed in a small, circular alumina sample pan and loaded into the heating compartment of the instrument.

X-Ray Diffraction

A Panalytical X'PertPRO MPD diffractometer was used with a Cu K α source ($\lambda = 0.154184$ nm) and an X'Celerator ultrafast RTMS detector. XRD configurations consisted of an angular resolution (in 2θ) of 0.001° and a 0.04 rad soller slit, and a 1° divergence slit. A 20 mm mask was used on the incident beam path, while a 6.6 mm anti-scatter slit and a 0.04 rad collimator were used on the diffracted beam path.

Brunauer-Emmett-Teller Analysis (BET)

BET analysis of the TiO₂ composites was performed to investigate the relative porosity and surface area of the composites before and after heat treatments. The analysis was completed using Quantachrom Instruments Nova1200e Surface Area and Pore Size Analyzer, and NovaWina software for data acquisition.

3.5.4 Photovoltaic Analysis

Current-Voltage Measurements (I-V Measurements)

Current-Voltage curves were generated by a 1286 electrochemical Interface from Solartron Analytical, U.K., using full combo Zplot/corrware software by Scribner Associated Inc., U.S.A. During irradiation measurements, the cell was placed underneath an Asahi Spectra HAL-320 Sun Simulator measuring 1 sun at AM 1.5 G. Prior to experiments, calibration was performed with an Asahi Spectra sun checker to verify the intensity of the irradiance to be within $\pm 1\%$ of 1 sun.

Quantum Efficiency (IPCE)

IPCE was measured in DC mode by a custom made apparatus between wavelengths of 400-800 nm and a scan interval of 5 nm. The instrument was made with a 250 W halogen lamp

(Newport-Oriel), a Spectral Products CM110 1/8 m monochromator with variable resolution slits, a Newport broadband beam splitter, a calibrated poly-Si detector, and all of the necessary lenses to focus the beam of light. Data was collected with a National Instruments NI 9219 24-bit universal analog input, and the control software was written by LabView. All of the measurements were done in wavelengths ranging from 400 to 1100 nm with a scan interval of 5 nm.

Chapter 4

Carbon Nanotube Preparation and Separation Results

4.1 Carbon Nanotubes Grown by Chemical Vapour Deposition and High-Pressure Carbon Monoxide

4.1.1 Characterization of CNTs Grown by Chemical Vapour Deposition

Utilizing the procedure outlined in Chapter 3, carbon nanotubes prepared by chemical vapour deposition (CVD) consistently contained aligned forests of nanotubes mixed with CNTs in spaghetti formation and amorphous carbon. Previous work using this growth method has shown that samples prepared under a nitrogen or argon gas flow of around 100 sccm have a larger portion of CNTs growing in straight and uniform bundles. Samples grown under a high gas flow (> 300 sccm) have larger portions of CNTs in a spaghetti formation.

In this study, CNTs were prepared by the CVD method using a mixture of the carbon precursor and catalyst in the solid and vapour phases. Raw samples of the prepared tubes were characterized using SEM, Raman and UV-vis-NIR spectroscopy, and TGA. Similarly, carbon nanotubes prepared by the HiPCO method were also characterized using the same techniques.

SEM images, at varying magnifications, of CNTs grown with mixed precursors in the vapour and solid phases are shown in Figures 4-1 and 4-4. The images in Figure 4-1 indicate the height of the bundled CNTs to be around 40 μm .

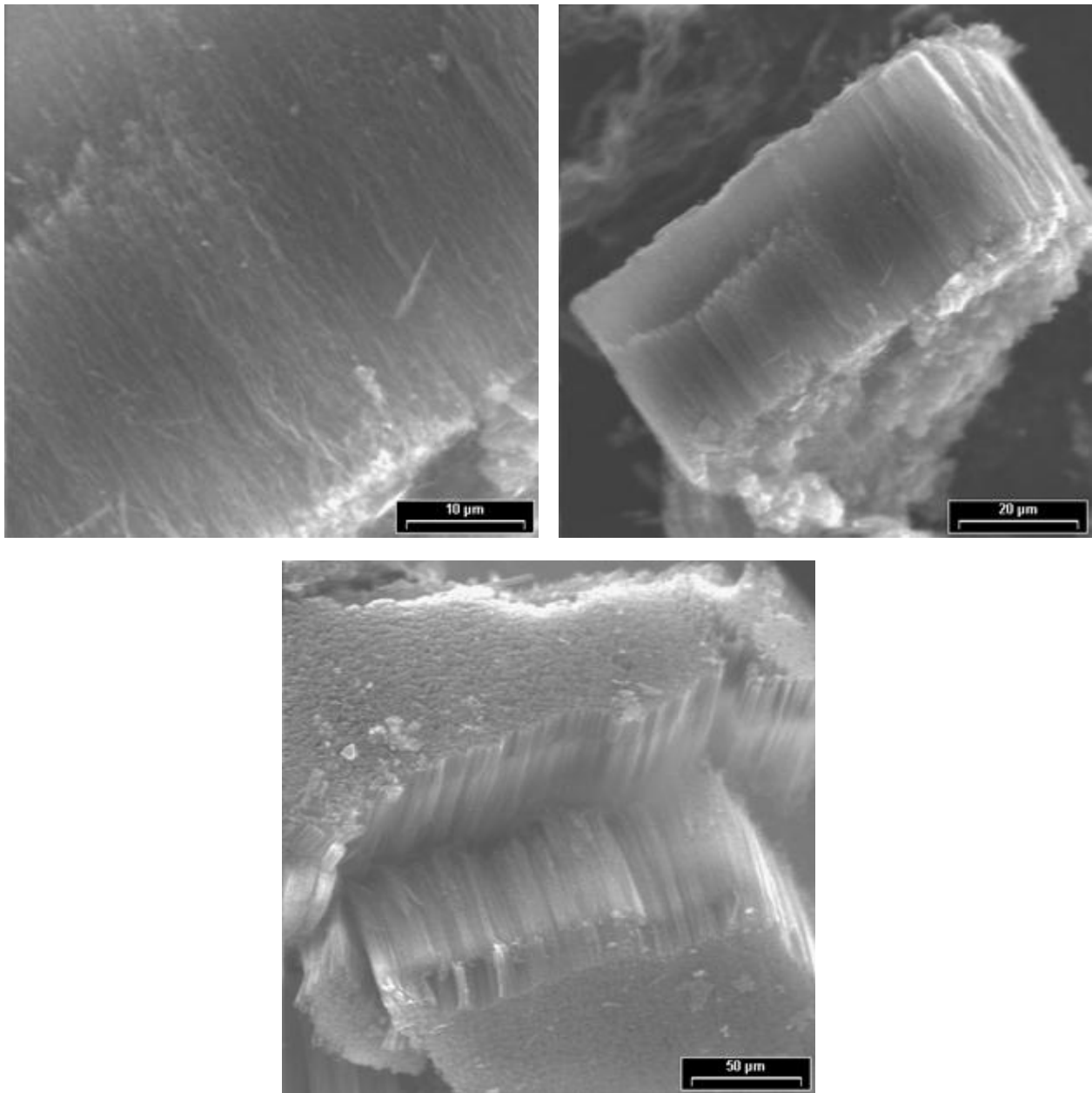

Figure 4-1: SEM images of carbon nanotubes grown by chemical vapour deposition where the catalyst and carbon precursor were mixed in the vapour phase. Deposition was done at 800°C, 150 sccm, with a 3.3 wt.% catalyst.

The Raman spectrum in Figure 4-2 reveals the varying kinds of CNTs grown by this technique. RBM bands are observed peaking at 210 cm^{-1} , 274 cm^{-1} , and 380 cm^{-1} . The presence of RBM bands indicates that there are either very small diameter multi-walled tubes or a large

fraction of single-walled tubes. Even though RBM bands are typically associated with single-walled tubes, if there is a small diameter inner tube (less than 2 nm), an RBM can be established at the right resonance condition. RBM signals are not observed from very large diameter tubes because the signal is too weak and the average inner tube in multi-walled tubes will cause the signal to broaden. The two characteristic peaks, namely the D band and G band are located at 1343.5 cm^{-1} and 1580.3 cm^{-1} respectively. The D band, otherwise known as the defect band, is due to the scattering of defects that break the symmetry of the graphene sheet. The G band is an intrinsic peak of carbon nanotubes. In primarily semiconducting CNTs, the G peak is split into two components: The G^- band and the G^+ band. The lack of G band splitting indicates that a large fraction of the nanotubes are metallic species, or multi-walled. The ratio of intensities between the G-band and D-band indicates the quality of the CNT sample. The Raman spectrum

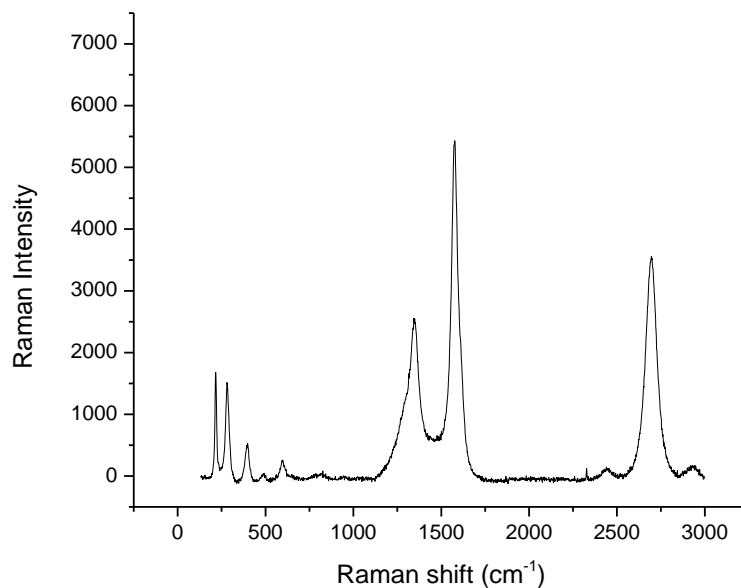

Figure 4-2: Raman spectrum of CNTs grown using chemical vapour deposition with the carbon precursor and catalyst mixed in the vapour phase.

depicted in Figure 4-2 has a G to D band ratio of approximately 0.5, indicating a moderate quality sample.

The thermal degradation behaviour was studied using thermo-gravimetric analysis (TGA). The thermal stability of the carbon nanotubes displayed no significant weight loss up to ~500°C with the peak rate of CNT oxidation observed at 604°C, when approximately 71% of the original mass had been lost. At 1000°C, the residual weight of catalyst particles is 6.8%. While the presence of defects lowers the onset temperature of CNT oxidation, the sample contains a significant fraction of large diameter and multi-walled tubes which therefore raises the starting temperature of thermal degradation. The narrow temperature range in which material combusts indicates a smaller fraction of carbonaceous impurities in comparison to other CNT growth techniques.

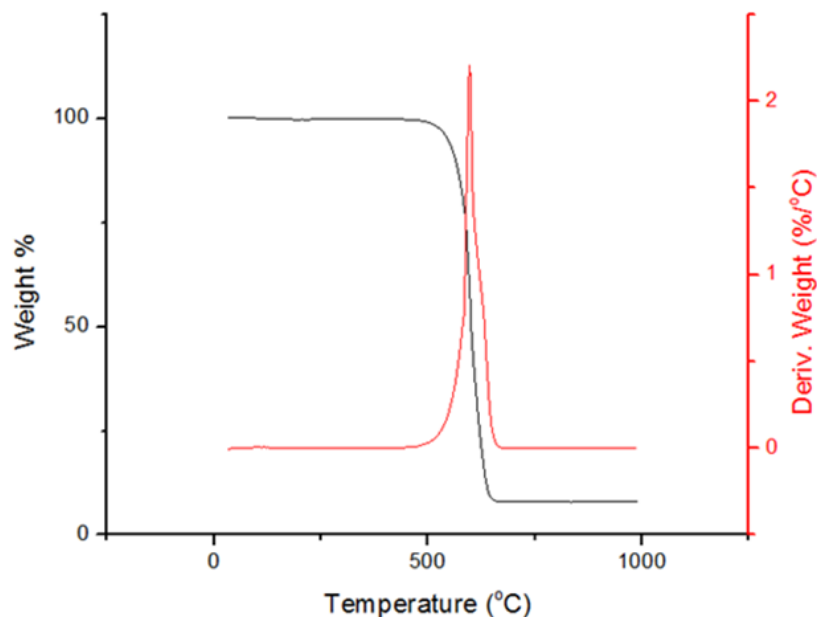

Figure 4-3: TGA of carbon nanotubes grown by CVD.

Looking at the SEM images in Figure 4-4, CNTs grown with the precursors mixed in the solid phase did not grow as neatly aligned as the ones prepared with the precursors mixed in the vapour phase. Mixing the carbon precursor with the catalyst in the solid phase is not ideal because of the different boiling points of the two substances. Ferrocene vaporizes at 249°C, while the camphor boils at 204°C. This results in an insufficient amount of catalyst particles in the growth environment prior to the ferrocene completely entering the furnace followed by an overabundance of the same catalyst. Having a growth environment high in catalyst particles increases the amount of amorphous carbon around the CNTs which affects the growth alignment.

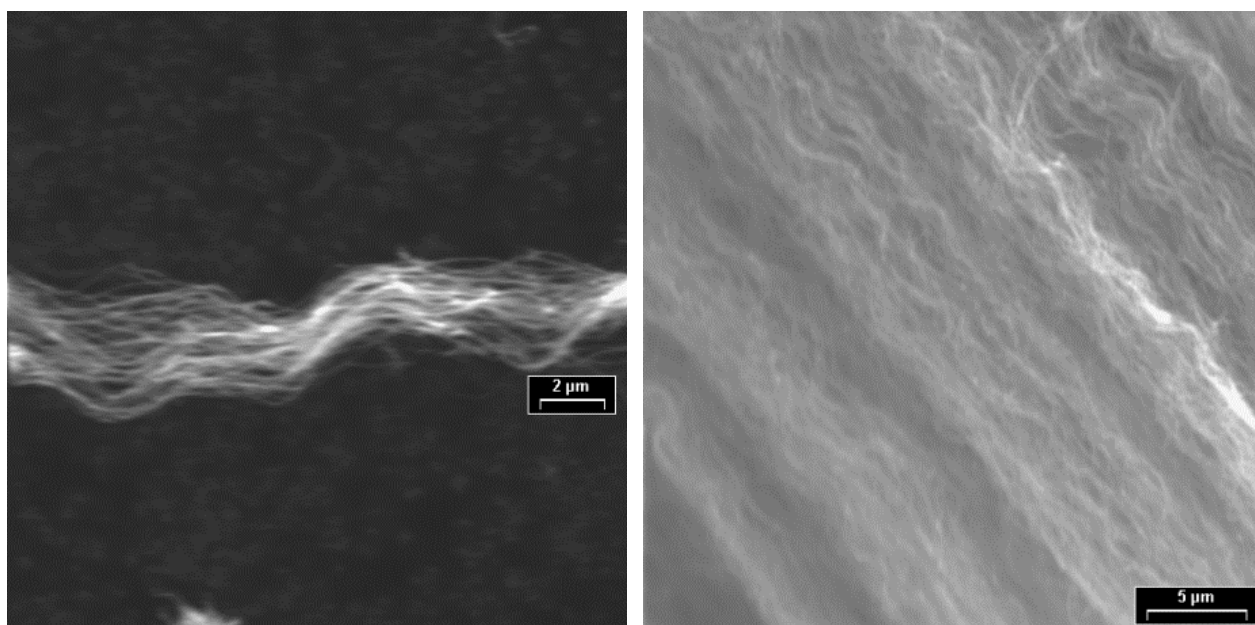

Figure 4-4: SEM images of carbon nanotubes grown by chemical vapour deposition where the catalyst and carbon precursor were mixed in the solid phase. Deposition was prepared at 800°C, 150 sccm, and a catalyst of 3.3 wt. %.

Raman analysis for solid-phase precursor mix samples (see Figure 4-4) indicates RBM bands at approximately 210 cm^{-1} , 276 cm^{-1} , 390 cm^{-1} , 481 cm^{-1} , and 579 cm^{-1} , with 210 cm^{-1} and 271 cm^{-1} being the most intense. Again, RBM bands in the spectrum indicate the presence of

SWNTs or very small diameter MWNTs that are under good resonance conditions. The G-band is located at 1572 cm^{-1} and isn't split into G^- and G^+ . This indicates large diameters in the mixture with a large fraction of metallic species. A high intensity D band is found at 1343 cm^{-1} indicating that a large portion of the nanotube mixture is amorphous. The ratio of intensities between the D band and G band is approximately 0.71 indicating these tubes are of lesser quality than the ones where the precursors were mixed in the vapour phase.

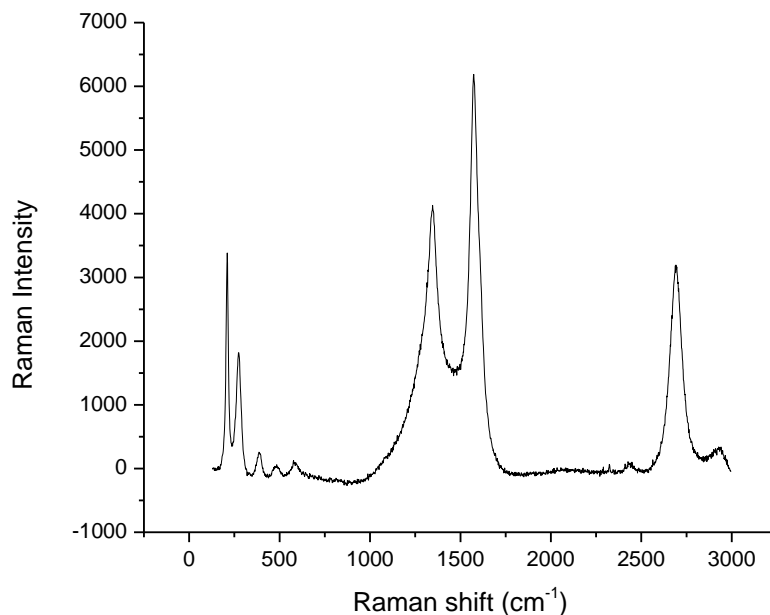

Figure 4-5: Raman Spectroscopy of carbon nanotubes grown by CVD. The precursors were mixed in the solid phase.

The thermal degradation of the CNT samples prepared with a solid-phase precursor mix begins at 510°C ; the rate of combustion peaks at 621°C , resulting in a 74% reduction in weight (see Figure 4-6). The narrower range of temperature indicates a smaller variety of CNTs, with less carbonaceous impurities. The high onset temperature confirms the Raman and SEM data,

revealing a high fraction of multi-walled CNTs and nanotubes with large diameters. The large fraction of multi-walled structures negates the thermal degradation effects of defects in the graphene structure. The residual weight was 10.5% of the original mass loaded into the TGA instrument indicating a high amount of iron catalyst left in the CNT mixture.

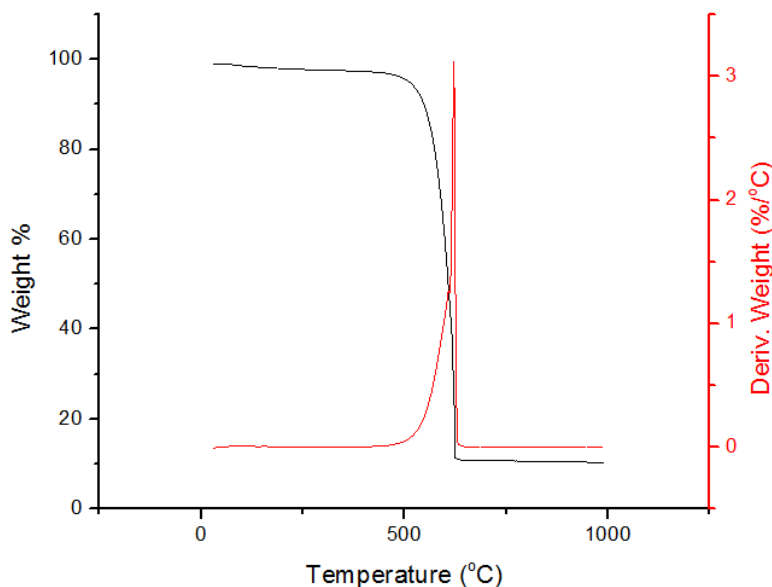

Figure 4-6: TGA of CNTs grown by CVD with precursors mixed in the solid phase.

Home grown CNTs were dispersed in a 2 wt% SDS solution and analyzed using UV-vis-NIR spectroscopy. Peaks in the absorption spectra (Figure 4-7) show the presence of semiconducting species at a range of diameters. Narrow peaks indicate the absence of a continuous range of semiconducting tubes in the mixture. The absorption of many of the intense peaks at higher wavelengths indicates a greater fraction of semiconducting tubes with larger diameters.

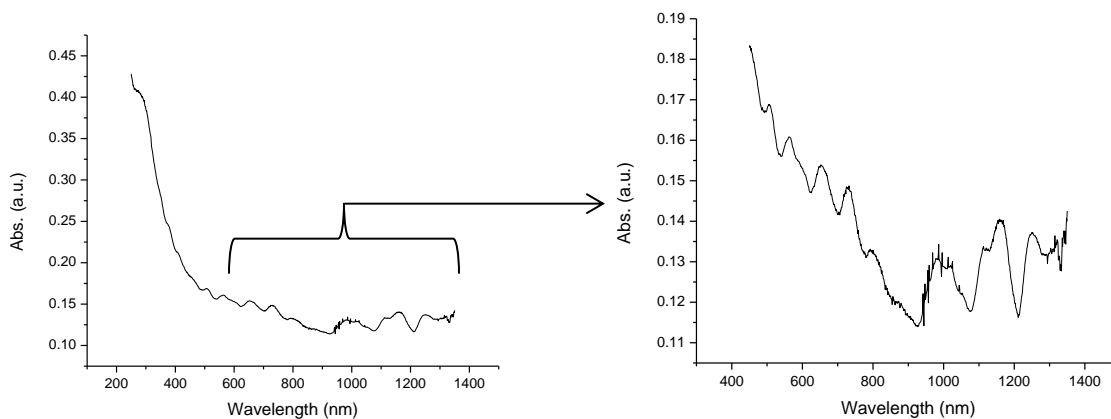

Figure 4-7: *UV-vis-NIR spectroscopy of CNTs grown by CVD dispersed in a 2 wt% SDS aqueous solution.*

4.1.2 Characterization of CNTs Grown by High Pressure Carbon Monoxide

SEM images of the tubes prepared via the HiPCO method (Figure 4-8) reveal tubes that are not aligned, but form a mass of tubes that have grown in the spaghetti formation. The tubes measured approximately 600 nm in length, and are therefore longer than those grown by CVD. HiPCO tubes have small diameters ranging from 0.8 to 1.2 nm.

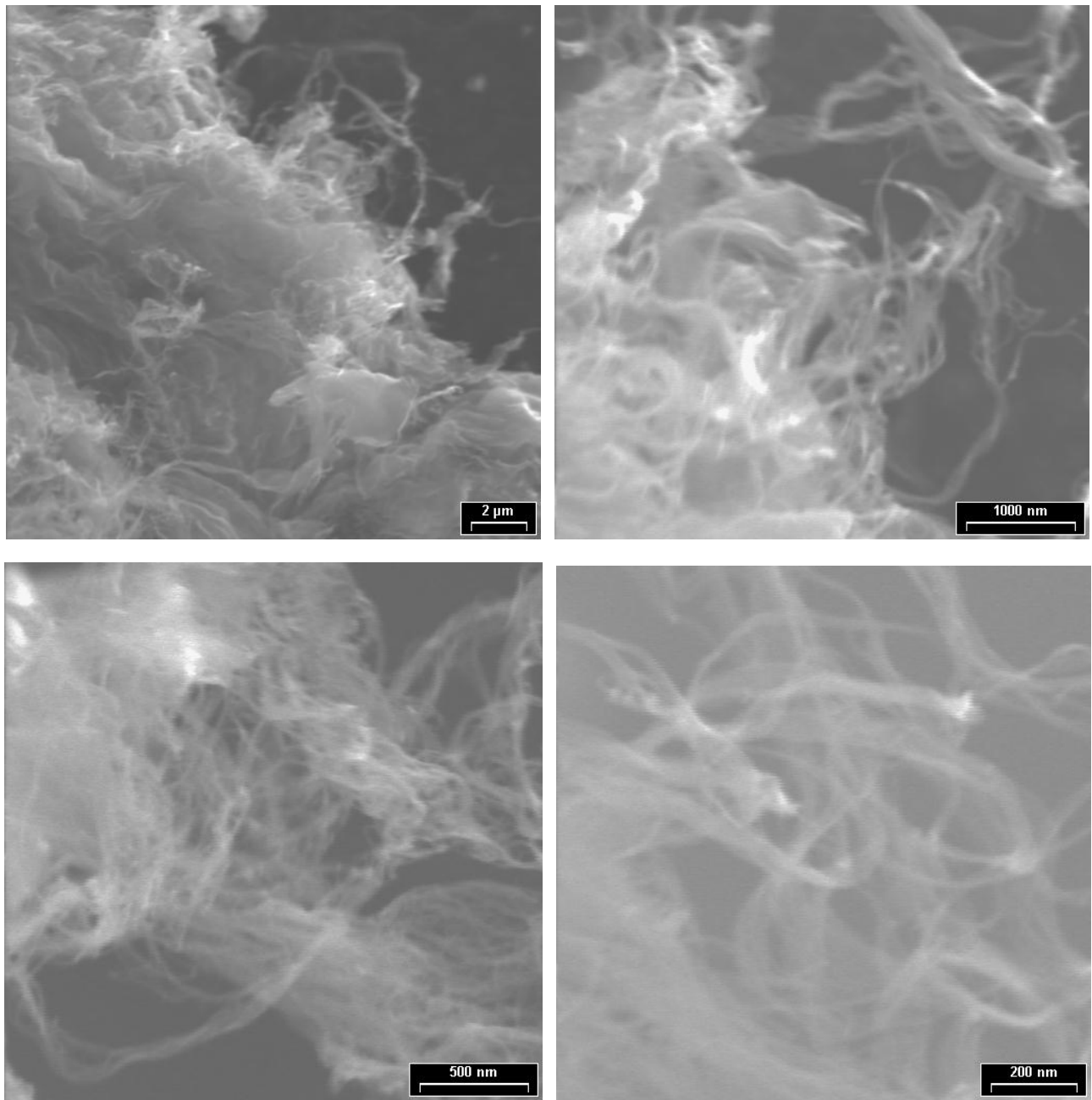

Figure 4-8: SEM images of carbon nanotubes grown by high pressure carbon monoxide.

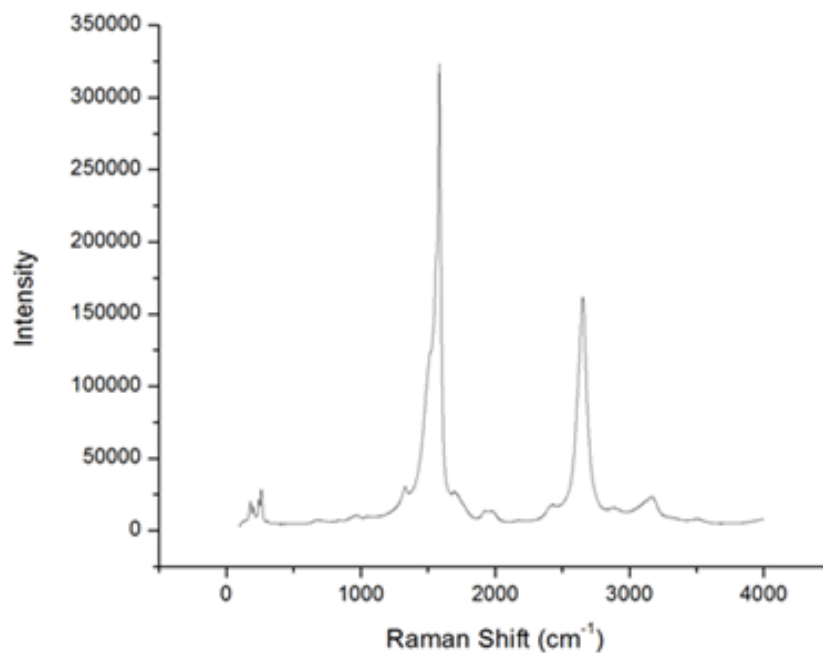

Figure 4-9: Raman Spectrum of carbon nanotubes prepared by high-pressure carbon monoxide

Figure 4-9 shows that the RBM bands for HiPCO carbon nanotubes are located at 200 cm^{-1} , 242 cm^{-1} , and 263 cm^{-1} . The bands' close proximity confirms the small range in diameters obtained by this growth method. The low intensity of the D band (located at 1330 cm^{-1}) suggests the nanotubes grown by the HiPCO procedure contain few defects. The G-band is split into G⁻ (1529 cm^{-1}) and G⁺ (1587 cm^{-1}) illustrating a large fraction of small diameter, semiconducting, and single-walled carbon nanotubes. The ratio of intensities between the D and G bands is 0.09, indicating a high quality sample.

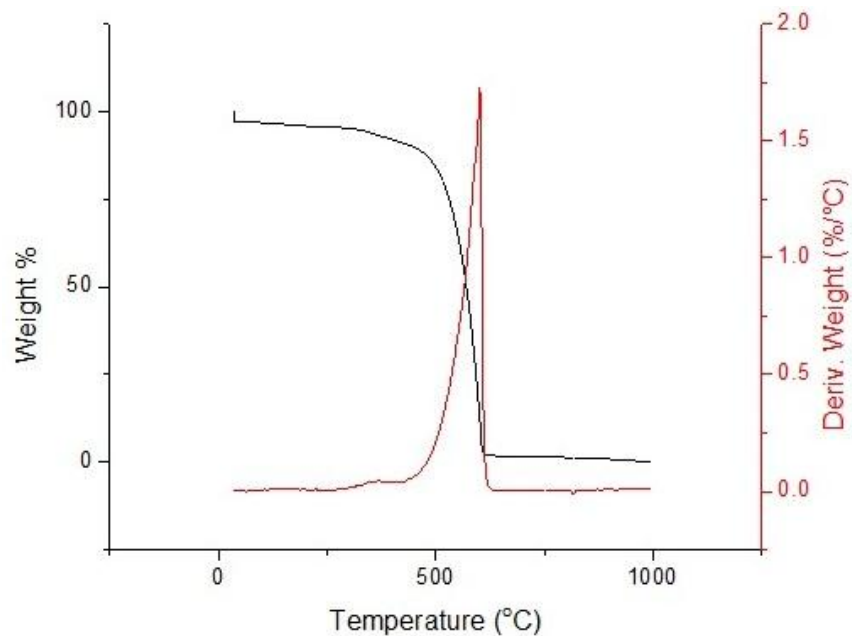

Figure 4-10: Thermogravimetric analysis of HiPCO prepared carbon nanotubes.

The thermal degradation of HiPCO prepared carbon nanotubes was also studied using TGA (Figure 4-10). The CNTs retained thermal stability until approximately 350°C, where the amorphous carbon begins to oxidize. At approximately 450°C, the smaller diameter SWNTs lose thermal integrity. At this temperature approximately 10% of the bulk weight is lost. The largest burning rate of the CNT mixture (the derivative weight peak), occurs at 550°C. The residual weight, composed of iron particles, makes up approximately 3.0%.

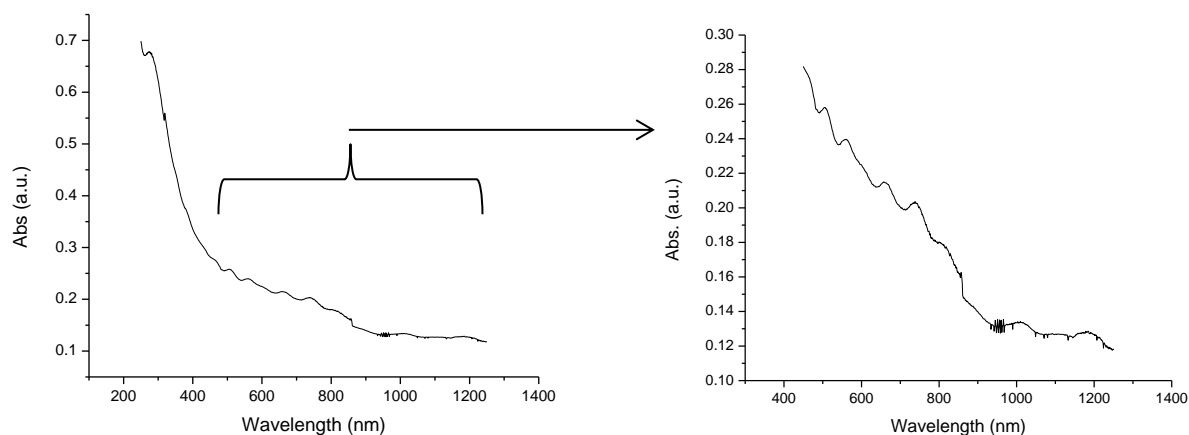

Figure 4-11: UV-vis-NIR spectroscopy of dispersed HiPCO carbon nanotubes in 2 wt% SDS.

Although it is difficult to make out the individual peaks, the spectra in Figure 4-11 reveals a series of broad peaks in the lower wavelength range, which was not evident in the CVD absorption spectra. This can be explained by the narrower range of diameters in the HiPCO tubes with a smaller variety than for those prepared by CVD. The existence of so many broad peaks in the mid to lower wavelengths confirms Raman spectroscopy data that shows a prevalence of semiconducting carbon nanotube species.

4.2 Carbon Nanotube Purification and Separation

The purity of single-chirality carbon nanotubes is important for a variety of electronic applications. The work presented in this section discusses the results obtained by two procedures reporting single-chirality nanotubes of varying purity. The impurities in each separated aliquot are metallic nanotubes and other semiconducting chiralities. The estimated purities of each of the separated (n,m) species were found using the area underneath each of the peaks in the optical

absorption spectra. Only the separated chirality fractions with the highest purity are presented and used for DSSC application.

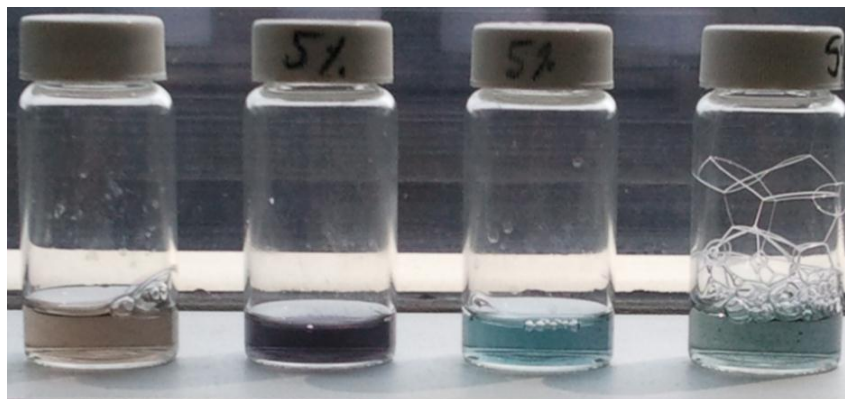

Figure 4-12: Photo of separated tubes via size-exclusion gel chromatography. Chiralities separated from vials left to right: (7,3)/(6,4); (6,5)/(6,4); (7,5)/(8,3)/(8,4); and (8,6)/(9,4)

4.2.1 Separation of Carbon Nanotubes Grown by CVD

To obtain some understanding of the distribution of the diameters for the CVD grown CNTs, these were first separated in a single column using 1 mL of Sephacryl gel (200HR). This was done to determine the presence of SWNTs small enough to become caught in the pores of the gel. UV-vis-NIR spectroscopy of the eluted tubes was then performed (Figure 4-13). A purple-blue colour indicated that this growth method was able to produce small diameter tubes; furthermore, separation of small diameter single chiralities from home grown tubes is possible, with some optimization, using gel chromatography. The prominent E_{11} peaks in Figure 4-13 are located at wavelengths 873 nm, 975 nm, 1053 nm, and 1122 nm which correspond to chiralities (6,4), (6,5), (10,2), and (7,6) respectively. ^[55] Dual or single chirality separation was achieved by

increasing the quantity of initial CNT solution loaded into the column thereby improving the selectivity of the gel.

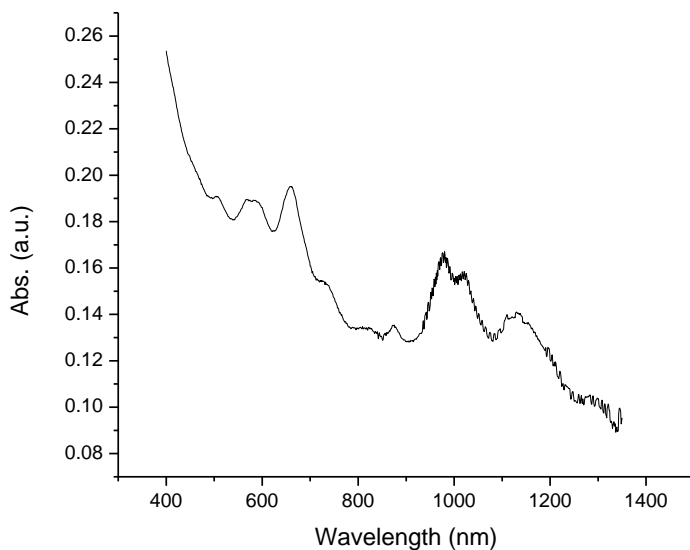

Figure 4-13: UV-vis-NIR spectrum of 1 mL single column separation of carbon nanotubes grown via chemical vapour deposition.

4.2.2 Separation of Carbon Nanotubes Grown by HiPCO

Single chiralities were successfully separated following the two-pass procedure written in Chapter 3 and reported in a paper by Liu et al.^[106] Figure 4-14 shows the optical absorption spectra of the semiconducting SWNTs after the first separation (left) and second separation (right) resulting in a highly enriched solution containing the (7,3) chirality. The (7,3) chirality has a E_{11} absorption band located at 990 nm and an E_{22} absorption band at approximately 510 nm. For DSSC application, the combination of being a relatively simple chirality to isolate, and

the location of its absorption peaks being where they do not overlap the dye, makes the (7,3) species an ideal chirality to target in separation procedures.

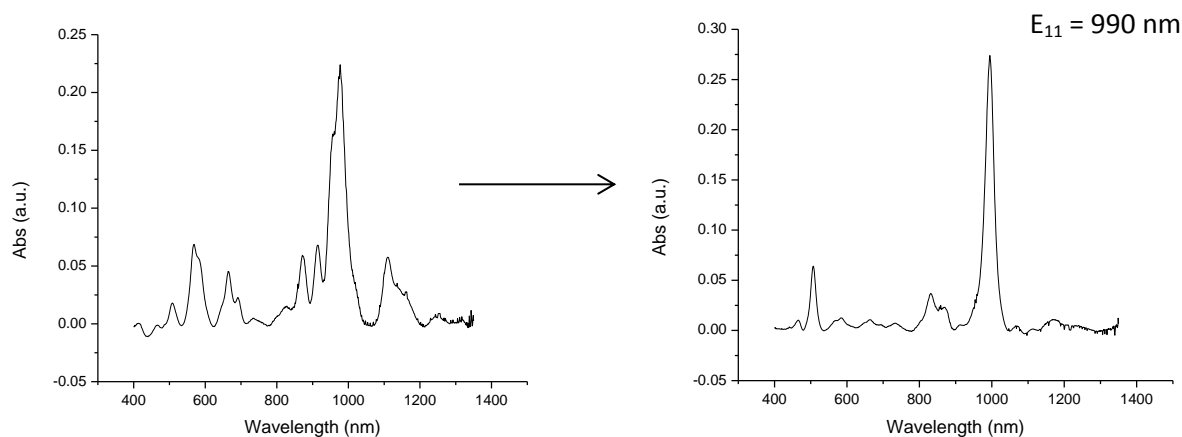

Figure 4-14: Optical absorption spectra of the two-step separation of the (7,3) chirality. Absorption spectrum of the 1st column is on the left and the absorption spectrum of its second separation is on the right.

As discussed in Chapters 1 and 3, the trapped semiconducting SWNTs are easily desorbed and eluted by loading a higher concentration of surfactant. This indicates that CNTs with greater coverage of SDS have reduced interaction with the gel. In a 2013 paper, the Strano group^[159] suggested a model to explain the interactions between SDS and hydrogels that results in the chiral separation of SWNTs made from the HiPCO process. They demonstrate that the separation of single-chirality SWNTs is a kinetically driven forward adsorption process.^[159] As SWNTs pass through the stationary bed of ally dextran gel, the chiralities with the largest affinity are adsorbed into the pores of the gel and separated from the bulk solution. After the solution passes through many gel beds, the chiralities with less affinity are adsorbed as well leaving multi-walled, large diameter, and metallic tubes behind. Since a larger micelle reduces

interaction, smaller diameter SWNTs are first captured by the gel. The results presented in this study agree with this trend as the smaller diameter (7,3) chirality is always observed in the 1st column's absorption spectrum, and mixtures of other chiralities are observed in subsequent columns in order of their diameter.

One drawback to separating by gel chromatography is a limited yield of separated tubes obtained after every pass, as after each pass through the gel, approximately 1% of the tubes are irreversibly adsorbed. ^[106] This suggests that it would be ideal to limit the number of iterations. In this work we targeted and isolated single chiralities from the bulk SWNT solution by adding enough solution to overload the column in order to obtain a high enough purity in a single pass. This involves using a different loading procedure for each of the chiralities desired. One disadvantage to this method is that the procedure requires optimization for every batch of tubes prepared. See section 3.2.2 for the procedures used to separate enriched (7,3) and (6,5) solutions.

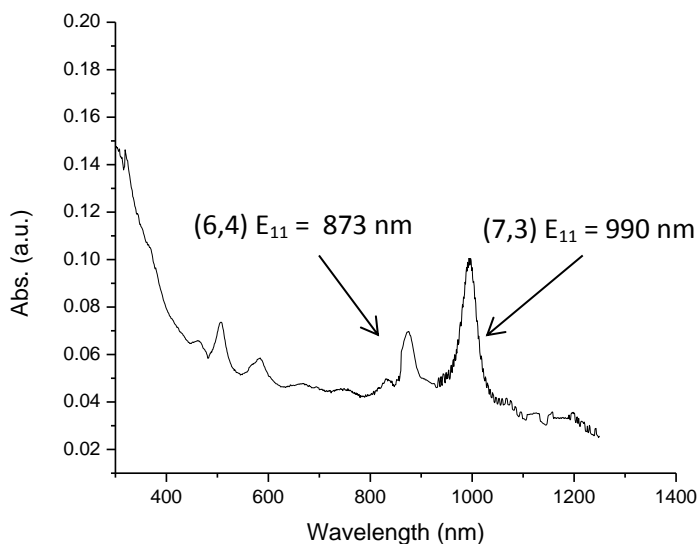

Figure 4-15: UV-vis-NIR spectrum of single-pass separation of (7,3) and (6,4) chiralities.

Depending on the amount of CNT solution used to overload the column stack, columns mixed with (6,4) typically eluted from the 2nd column and were either mixed with (7,3) or (6,5). An attempt to isolate (6,4) from the bulk was unsuccessful. To demonstrate a trend in the performance of DSSCs with increasing chirality purity, the (6,4) mixed samples were used in the photoanode of the DSSCs for comparison. Figure 4-15 shows the absorption spectrum of a (7,3)/(6,4) mixture with purities of respectively. In Figure 4-16, the optical absorption spectrum is accompanied by a PL contour map to confirm the mixture of those two chiralities. The calculated purity of the (6,4) and (6,5) is 49.7% and 45.3% respectively.

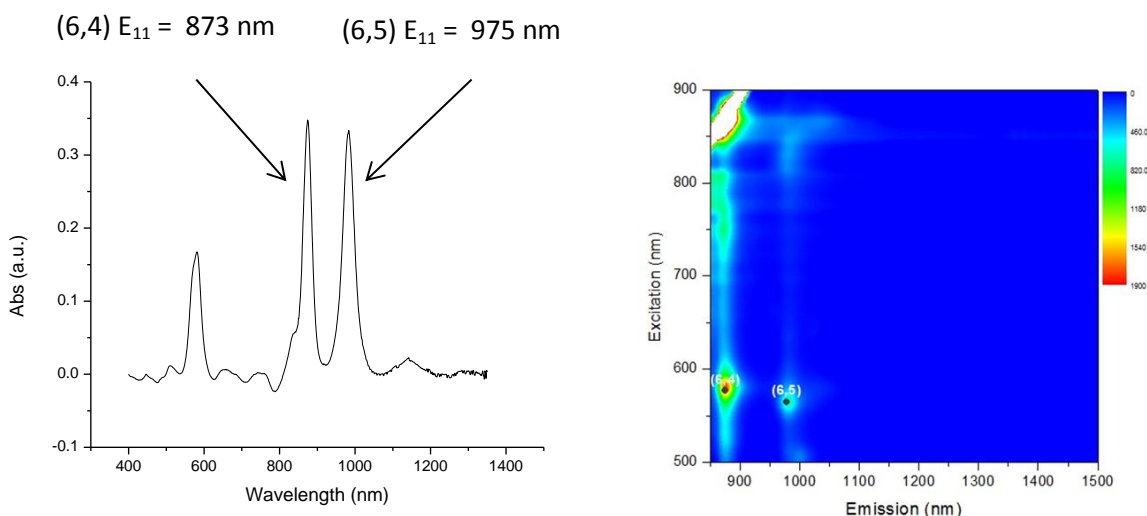

Figure 4-16: UV-vis-NIR Spectrum of single-pass separation of (6,5)&(6,4) chiralities. (Left) Photoluminescence map of (6,5)&(6,4) chiralities. (Right)

Figure 4-17 shows the absorption spectra of the highly-enriched (6,5) solution dispersed in 5 wt.% SDS. A photoluminescence counter map was used to reaffirm the purity of the (6,5) chirality, as in Figure 4-16. Using the UV-vis-NIR spectrum from Figure 4-16, the purity of (6,5) was calculated to be 93%. Based on the intensity of the metallic range of the UV spectra, both the (6,4)/(6,5) and (6,5) fractions had very little metallic species and few semiconducting

impurities. Based on the absorption spectrum of (7,3) in Figure 4-14, the intensity of the metallic range was quite small in comparison to the semiconducting peaks. In the case of the mixed (6,4)/(7,3) solution, however, there was a comparatively higher absorption intensity in the M_{11} range, indicating a larger presence of metallic species in the sample.

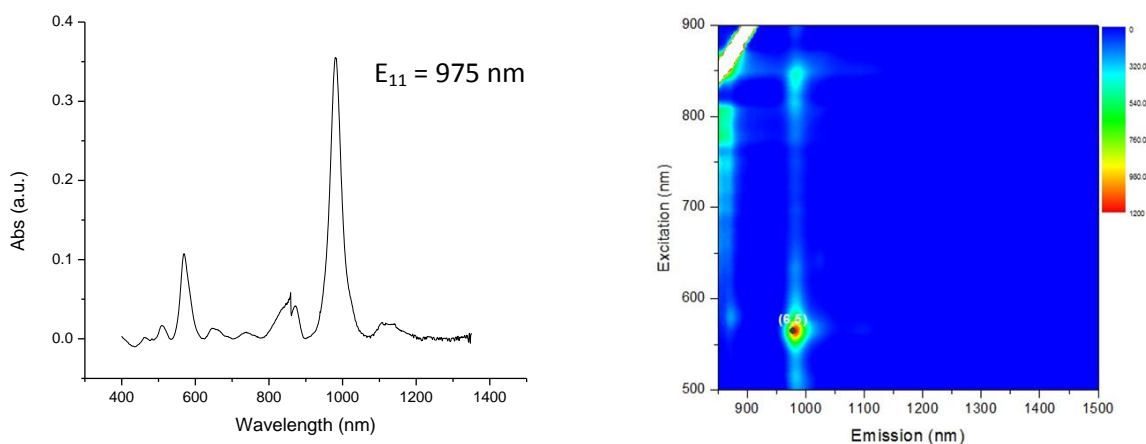

Figure 4-17: UV-vis-NIR Spectrum of single-pass separation of (6,5) chirality. (Left) Photoluminescence map of separated (6,5) chirality. (Right)

If a specific chirality is desired, the amount of CNT solution loaded can be optimized to increase the selectivity of the gel and target the chirality to elute out of a convenient column. However some chiralities will only separate at a low purity. As there is only a single surfactant used, low purity fractions can be collected for a second pass through the column, and if required, several rounds of separation can be performed until the desired purity is achieved. In 2013, the Kataura group, who published single-chirality results through gel chromatography, introduced temperature-controlled gel chromatography to isolate specific (n,m) species. Instead of relying solely on the interaction between the SDS, SWNTs, and the ally dextran-based gel to elute

desired chiralities, they incorporated temperature control to selectively modulate these interactions. The result is obtaining a larger range of chiralities with a single pass through the gel. The best optimization of this technique would occur if a specific chiral index was present in higher amounts in the starting CNT material (for example the enriched (6,5) nanotubes grown by the CoMoCAT method).

Chapter 5

Characterization of TiO₂ Composites and SWNT Thin Films

5.1 TiO₂ and CNT/TiO₂ Composite

Hydrothermal synthesis involves the growth of crystals under high water vapour pressure and temperature in order to promote nucleation. This results in TiO₂ with a high specific surface area. By adding carbon nanotubes, TiO₂ is chemically linked by functional groups to cover the CNTs. Synthesizing TiO₂ and SWNT composites by hydrothermal functionalization is a useful method as it does not require strong acid/base baths that result in the structural degradation of SWNTs. Milder techniques of functionalization are not favourable alternatives since they have a poor success rate and introduce impurities into the composite that are difficult to eliminate (for example, potassium in potassium persulfate). Similarly, templating agents, (i.e. surfactants) also introduce unwanted species. The high pressure and temperature required in the process creates an environment for intimate contact between the TiO₂ and SWNTs, resulting in improved mixing, less agglomeration, and better coating than the conventional methods of CNT/TiO₂ functionalization.

The surface morphologies of hydrothermally synthesized TiO₂ (see Figure 5-1) and TiO₂/CNT composites (Figure 5-2) were characterized by FESEM. The resulting images display a surface of TiO₂ with coarse grains and surface areas of varied size. With the addition of carbon nanotubes, the images reveal that there is a moderate amount of agglomeration.

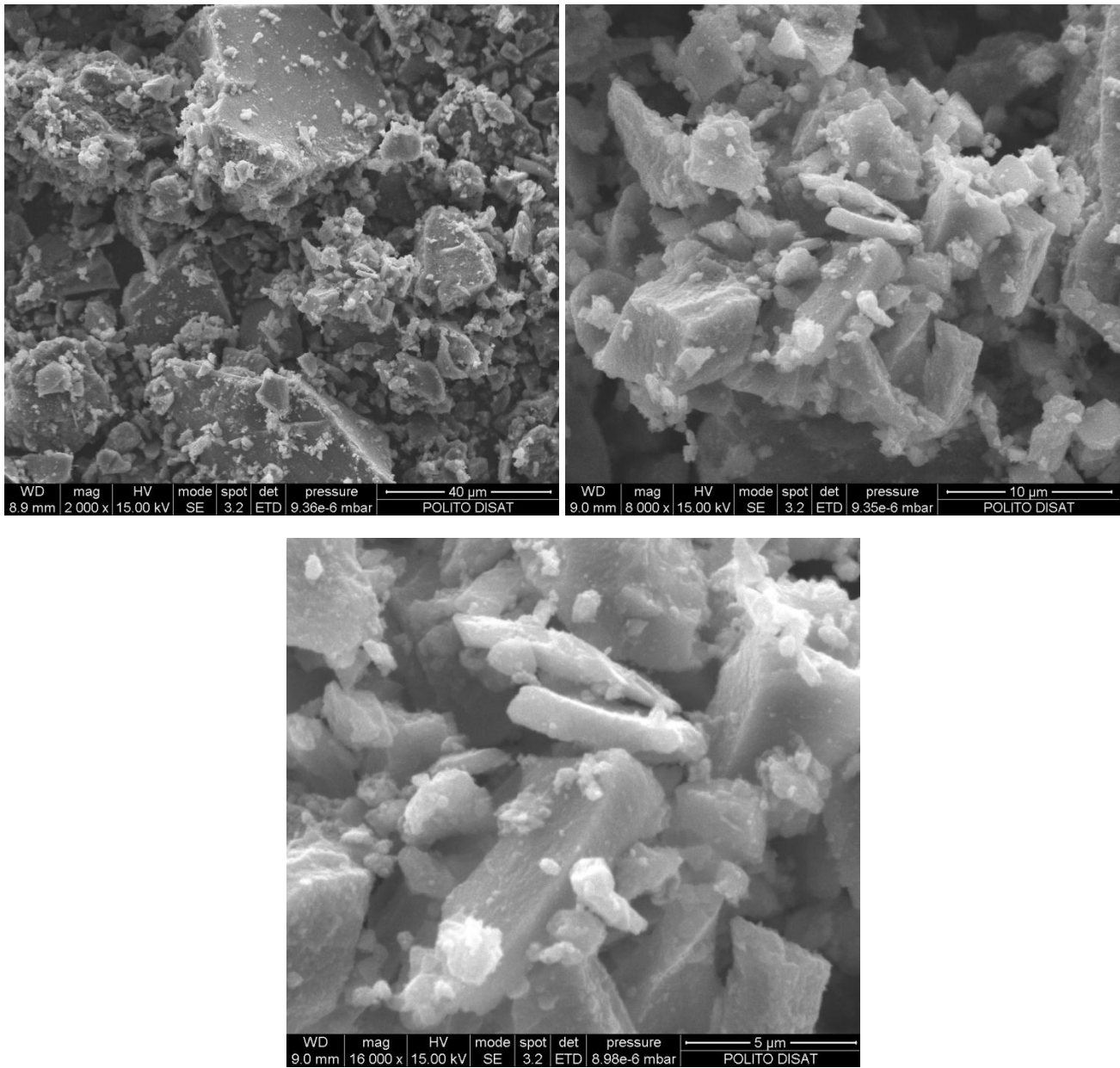

Figure 5-1: Field Emission Scanning Electron Microscopy (FESEM) images of varying magnifications of TiO₂ grown using the hydrothermal method.

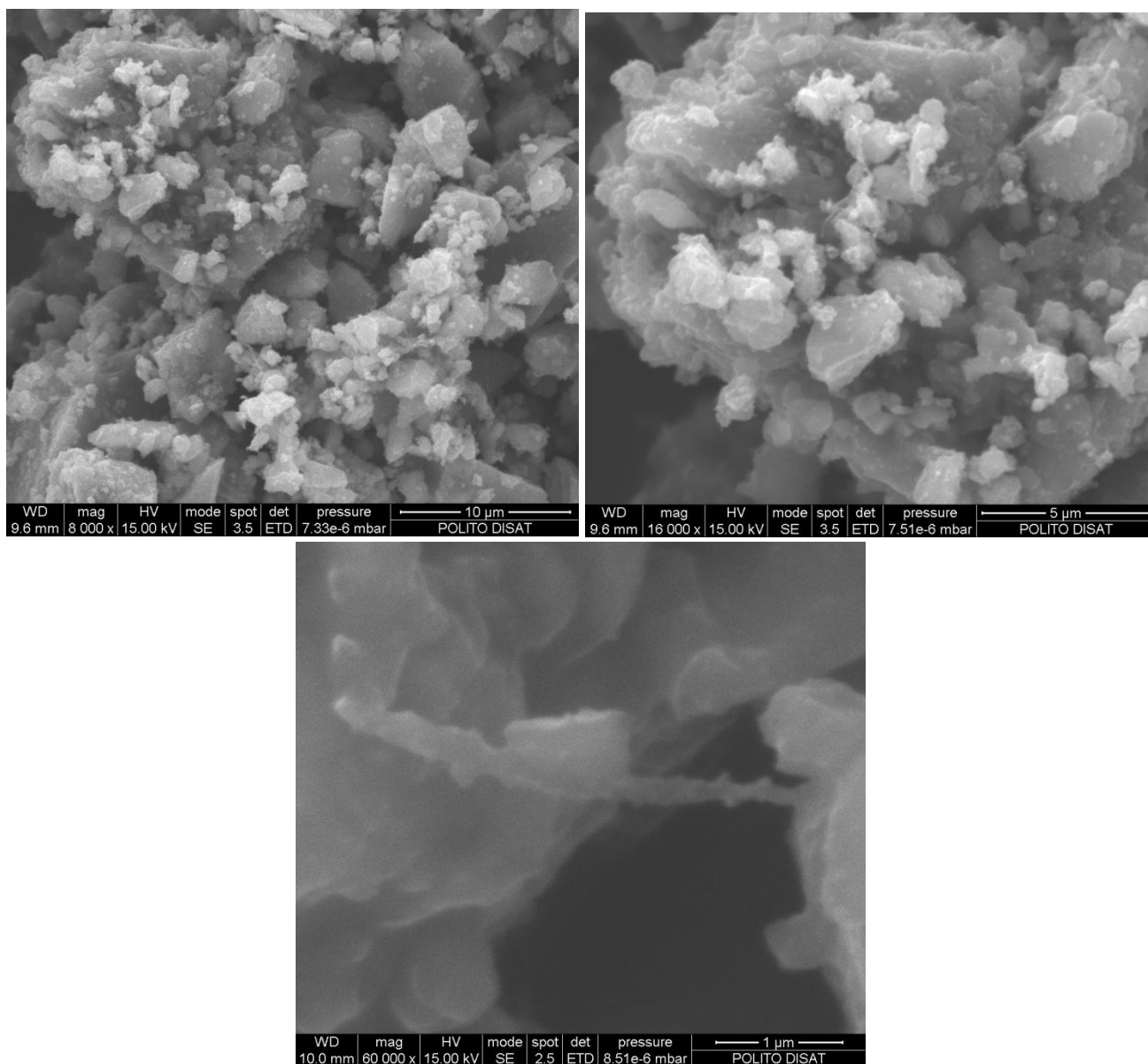

Figure 5-2: Field Emission Scanning Electron Microscopy (FESEM) images with varying magnifications of a CNT/TiO₂ composite grown using the hydrothermal method.

The EDS (see Figure 5-3) of TiO₂, synthesized without the presence of carbon nanotubes, reveals elemental compositions of 28.3 wt% of oxygen and a 70.5 wt% of titanium. The remaining 1.2 wt% was the escape peak of silicon, originating from the EDS detector. The

element composition of the TiO_2/CNT composite were identified by the EDS as 11.3 wt% of carbon, 46.3 wt% of oxygen, and 42.3 wt% of titanium.

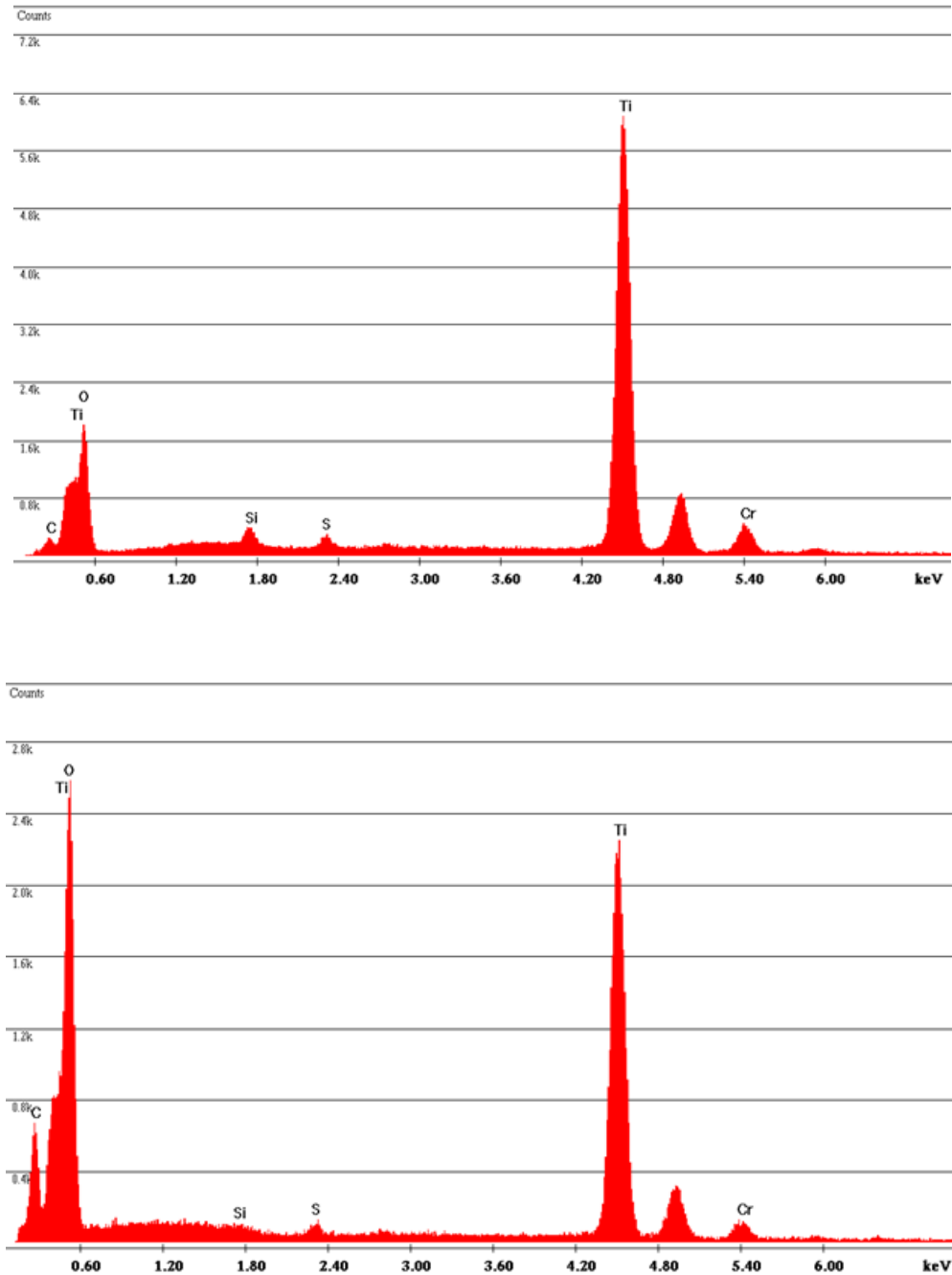
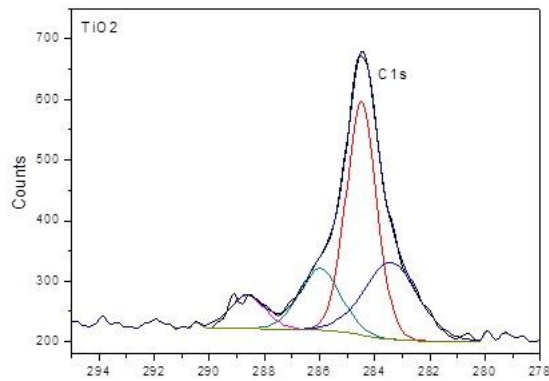
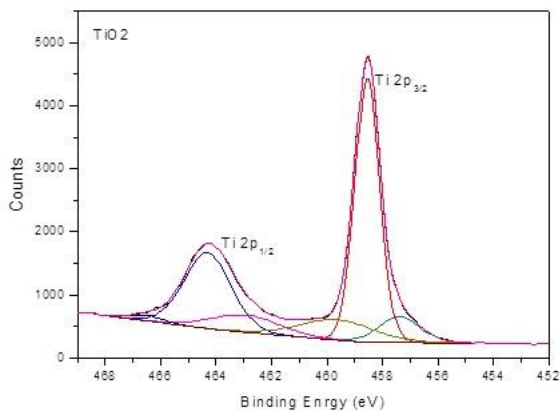

Figure 5-3: Energy Dispersive X-Ray Spectroscopy (EDS) of hydrothermally synthesized TiO_2 (top) and a CNT/TiO_2 composite (bottom).

The carbon on the surface of the TiO₂ powder (Figure 5-4) results from the residual species of the synthesis. Carbon bonds formed from the acetate and alkoxide by-products, as well as from the residual isopropoxide in the synthesis. Carbon was an inevitable impurity (otherwise known as adventitious carbon) during XPS as it occurs from exposure to the atmosphere. Adventitious carbon is mainly composed of single and double-bonded (short chain) hydrocarbon species that have peaks identified between 284.5 and 285 eV. In the TiO₂/CNT composite (Figure 5-5), the carbon bonds resulted from both the adventitious carbon and the carbon nanotubes incorporated into the composite. The carbonyl group in the XPS from the composite was at a higher percentage than in the XPS of the TiO₂ powder due to the functional groups attached to the CNTs.



	Peak (eV)	%	Bond
C _{1s}	283.4	27.7	carbide
	284.5	47.6	C-C/C-H
	286.0	16.9	C-O-C/C-OH
	288.6	7.8	C=O-



	Peak (eV)	%	Bond
Ti _{2p}	457.4	7.5	TiO
	458.5	46.8	TiO ₂
	459.7	10.7	TiO _x
	462.9	8.4	TiO
	464.3	25.3	TiO ₂
	466.5	1.2	TiO _x

Figure 5-4: XPS of TiO₂ Powder hydrothermally synthesized

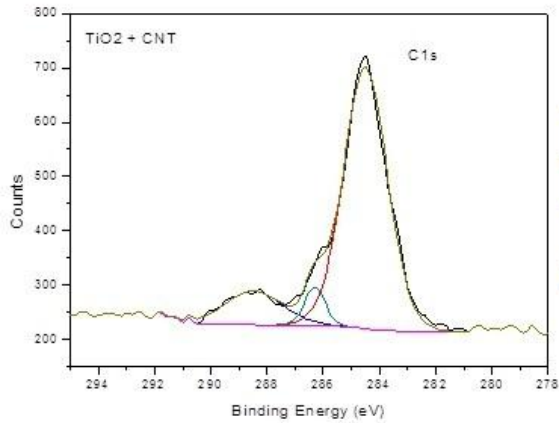

	Peak (eV)	%	Bond
C _{1s}	284.5	80.9	C-C/C-H
	286.3	5.5	C-O-C/C-OH
	288.5	13.6	C=O-

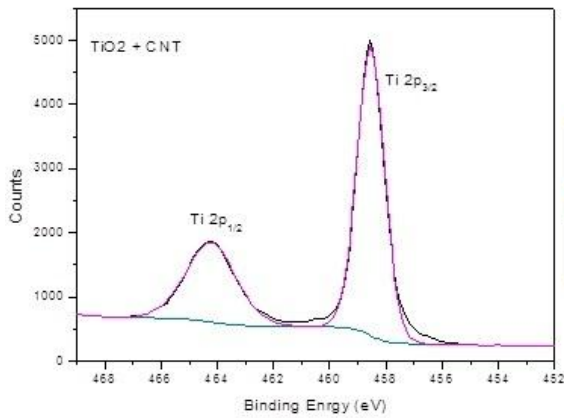

	Peak (eV)	%	Bond
Ti _{2p}	458.4	66.5	TiO ₂
	464.2	33.5	TiO ₂

Figure 5-5: XPS of TiO₂/CNT Composite hydrothermally synthesized

The CNT/TiO₂ composite (Figure 5-5) yielded TiO₂ peaks located at 458.4eV and 464.2eV, with no indication of non-stoichiometric phases. This is due to the CNT surface acting as a crystallization seed for TiO₂ (as supported by the XRD data in Figure 5-8). The TiO₂ synthesized by the hydrothermal method (Figure 5-5) indicated the presence of TiO_x and a very small amount of TiO on the surface. This is both an advantage and a disadvantage, as TiO_x introduces n-type defects (oxygen vacancies), whereas the TiO acts as an exciton quenching site.

The FTIR spectra in Figure 5-6 and Figure 5-7 revealed peaks located at 1140 and 1735 cm⁻¹, which are CNT and TiO₂-CNT signatures.^[165] The small peaks occurring near 1735 cm⁻¹

(in TiO_2) and 1745 cm^{-1} (in TiO_2/CNT composite) indicated the presence of a $-\text{COOH}$ group. Bonding between Ti-O is represented in the approximate region of 650 cm^{-1} . Carboxylic groups coordinated with Ti absorb at 1454 cm^{-1} and 1530 cm^{-1} respectively and belong to symmetric and asymmetric stretching modes. ^[166] The small bands located between 3000 and 2950 cm^{-1} are due to the stretching modes of C-H bonds from the residual isopropoxide and acetate and alkoxide by-products. ^[167]

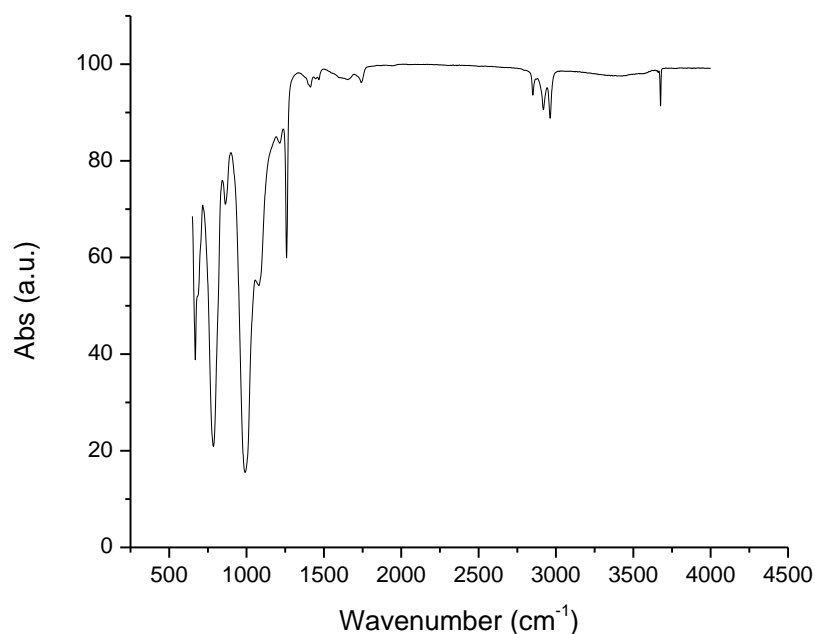

Figure 5-6: FTIR of hydrothermally synthesized TiO_2 powder

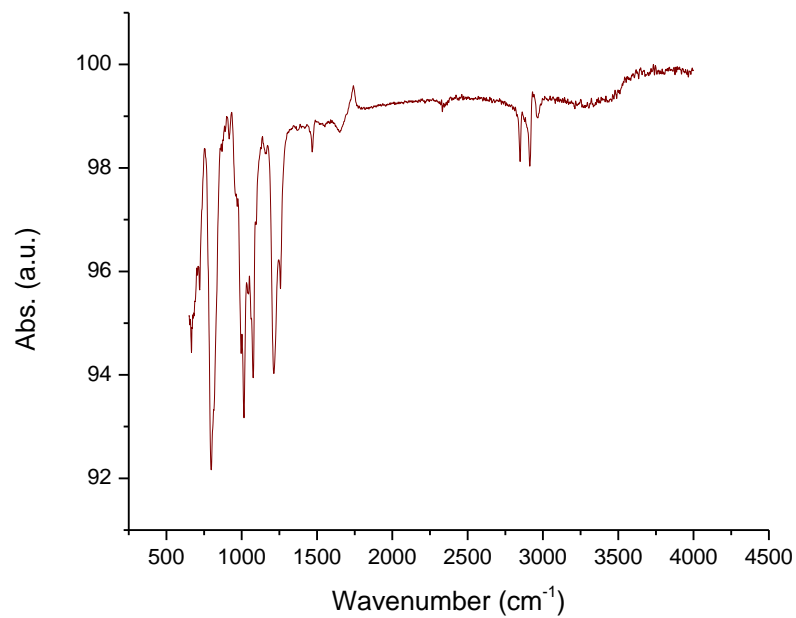

Figure 5-7: FTIR of hydrothermally synthesized CNT/TiO₂ Composite

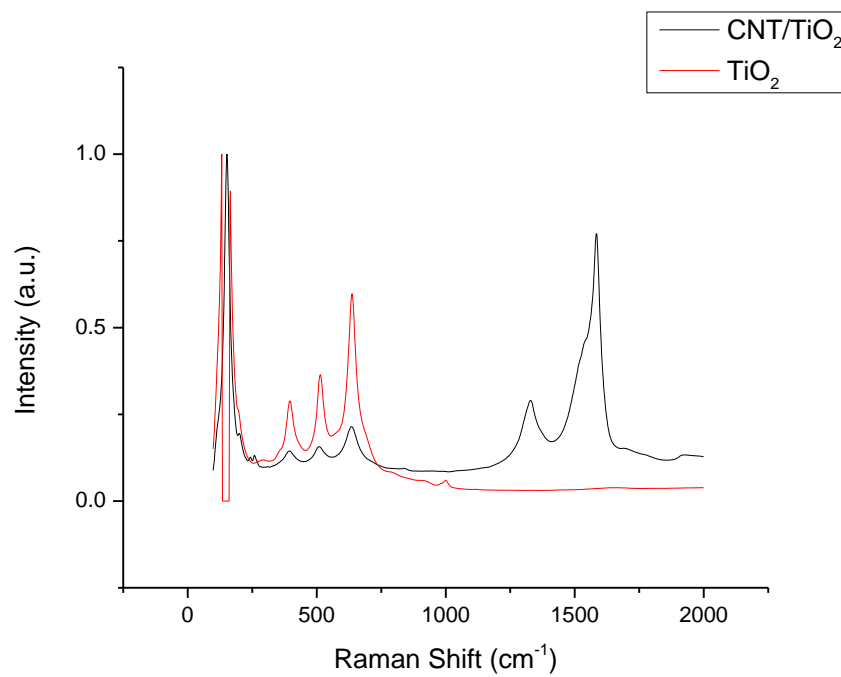

Figure 5-8: Raman spectra of TiO₂ and TiO₂/CNT composite

The anatase form of TiO_2 was represented by three peaks in the Raman spectrum (Figure 5-8) at approximately 393, 518, and 642 cm^{-1} . The other peaks located at approximately 1300 and 1624 cm^{-1} were the D and G bands of the HiPCO prepared CNTs. The intensity of the D band is higher than the Raman spectrum observed in section 4.1.2 of Chapter 4 due to the introduction of defects during the functionalization process. The intensity of G band splitting and RBM bands were reduced as a result of the weakened signal of the inner-diameter of the tubes and sparse distribution of CNTs. The results of the Raman data were confirmed by XRD. Figure 5-9 compares the XRD patterns of the hydrothermally synthesized TiO_2 and TiO_2/CNT composite. The peaks at 25.28° (101), 37.80° (100), 48.18° (200), and 54.09° (105) represent the anatase phase of TiO_2 and confirmed the absence of other TiO_2 phases. The XRD CNT peak was expected at 26.38° (002), however it was barely visible due to the small percentage of CNTs in the composite.

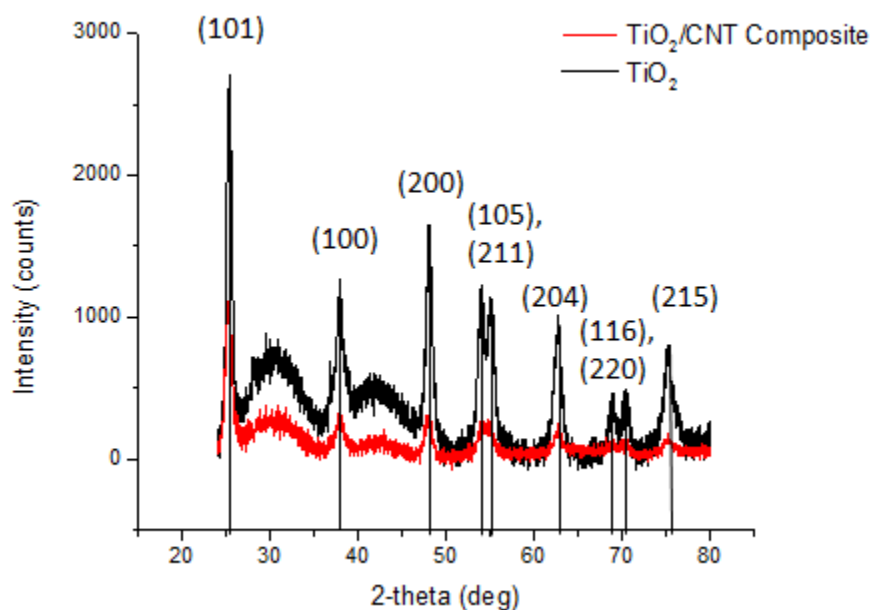

Figure 5-9: XRD Patterns of TiO_2 and TiO_2/CNT Composite

5.2 SWNT Thin Films

Due to the limited yield of the SWNT separation methods, an option that would allow less CNTs to be incorporated into the DSSC was the subject of some investigation. It was determined that not only would a film of SWNTs require less material for assembly, but would produce an interface closer to an ideal Schottky barrier in the photoanode of a DSSC. This section examines transmittance and sheet resistance results of the deposited SWNT films of both mixed and single-chirality.

The transmittance spectra, in Figure 5-10, demonstrated the amount of light that can travel through the film. The transmittance of the (7,3) chirality indicated no absorption peak in the range of maximum absorption of the dye. The other films yielded peaks in the region of the maximum light absorption in the dye. The (7,3) chirality is ideal for DSSC application with dyes that absorb in the IR region (i.e. black dye).

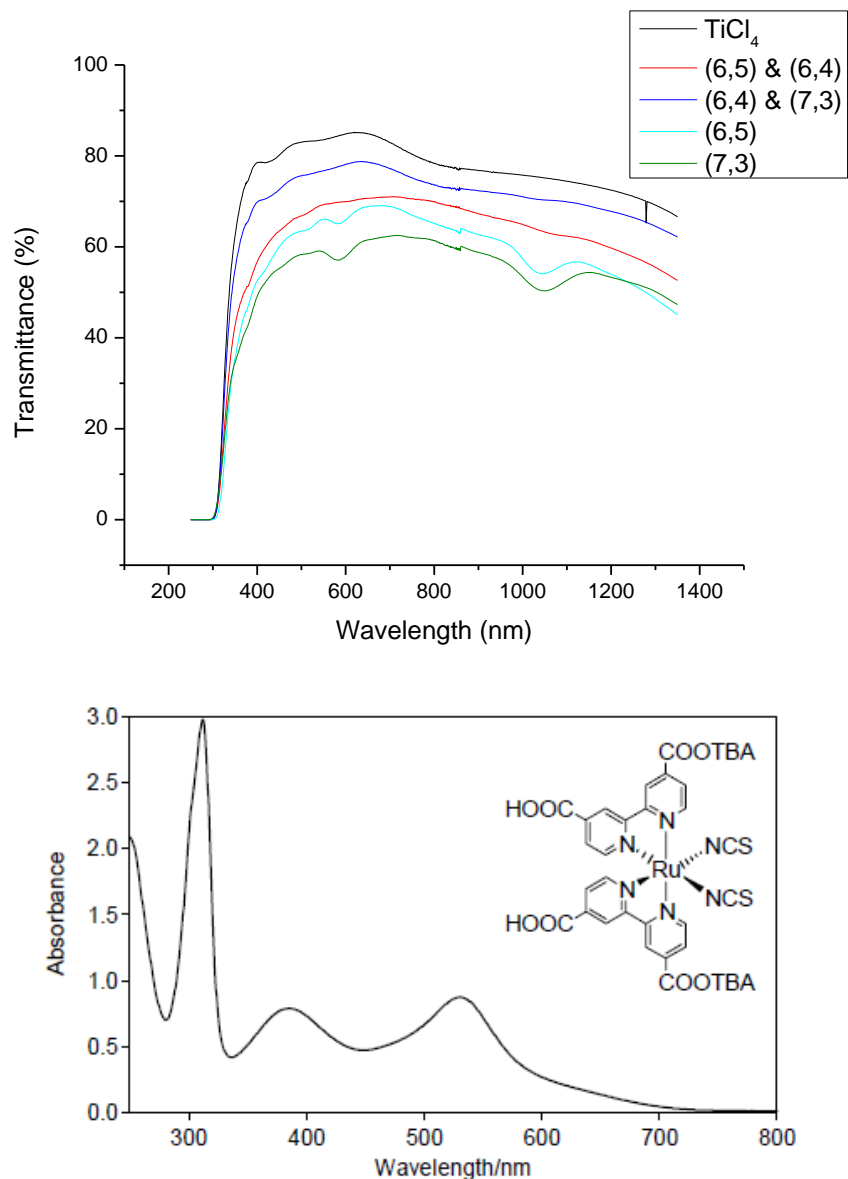

Figure 5-10: Transmittance measurements of chirality-specific films (**top**) and absorbance spectrum of N-719 dye (Reproduced with permission from Ref [19]) (**bottom**).

The resistance was lowest for the mixed chirality film due to the presence of metallic tubes. The mixed semiconducting chirality films ((6,5) & (6,4) and (7,3) & (6,4)) measured to have the highest resistance due to the film being composed of two semiconducting chiralities with different bandgaps and the absence of metallic species. The single-chirality films demonstrated a low resistance as the high purity film was composed of a single bandgap.

However, this resistance was not as high as the mixed chirality film, due to the purity of semiconducting species.

Table 5-1: Sheet Resistance measurements of chirality-specific films.

Chirality	Resistance (Ω)
Mixed Chirality	3 695
(6,4) & (6,5)	51 464
(6,4) & (7,3)	46 493
(6,5)	5 992
(7,3)	5 822

Chapter 6

Dye-Sensitized Solar Cell Performance

6.1 Performance of Cells with TiO₂, TiO₂/SWNT Composite, and SWNT Thin Film

The short circuit current (I_{sc}) is due to the generation and collection of charges. Its value is dependent on the amount of dye absorbed on the TiO₂ surface and the injection of electrons from the dye to the TiO₂. When the carbon nanotubes are put in contact with the TiO₂ surface, the Fermi level in each of the materials equalizes, as observed in standard semiconductor p-n junctions. The equalized Fermi level causes the conduction band of the TiO₂ to shift downwards with respect to the LUMO of the dye and the conduction band of the CNTs to shift down with respect to the conduction band in the TiO₂. The result is a greater drive for the electrons to travel from the dye to the conduction band of the TiO₂ and CNTs.

In Table 6-1 and in Figure 6-1 the solar-cell characteristics of the 3 configurations tested in this work are shown. In particular, a standard TiO₂ DSSC performance is compared with a TiO₂/CNT composite and a TiO₂ + CNT film configuration.

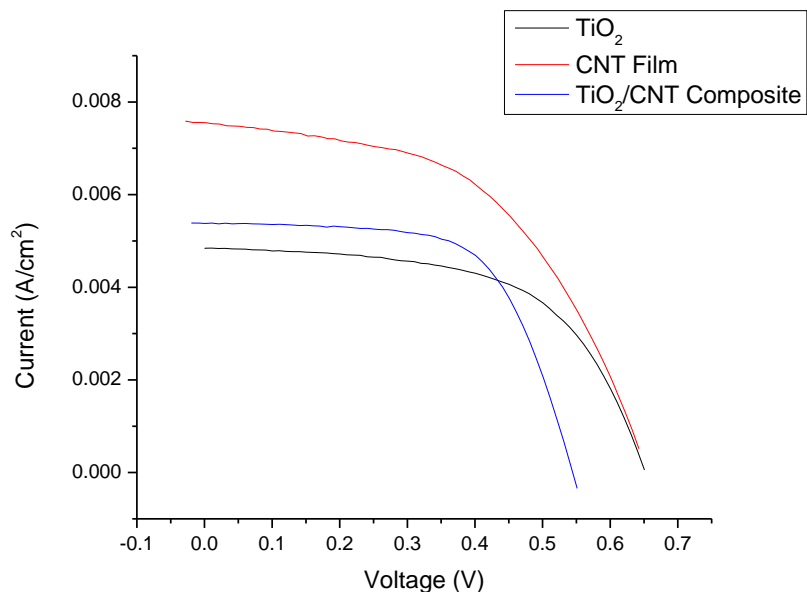

Figure 6-1: I-V Curves of DSSCs taken under an irradiance of 1 sun. The DSSC with the photoanode composed of the CNT/TiO₂ composite had the highest fill factor (FF) however the DSSC that performed with the highest efficiency (η) was assembled with separate CNT and TiO₂ films.

Table 6-1: DSSC performance parameters of devices made with photoanodes containing TiO₂/CNT composite, separate CNT and TiO₂ films, and TiO₂ alone.

	η	FF	I _{sc} (mA)	V _{oc} (V)	R _s (Ω)	R _{sh} (k Ω)	I _o (A)	m	IPCE
TiO ₂	1.85%	58%	4.94	0.651	24.80	2.9	7.9×10^{-7}	2.56	15%
TiO ₂ /CNT Composite	1.88%	63%	5.40	0.551	19.03	1.1	1.0×10^{-4}	1.80	26%
TiO ₂ /CNT Film	2.52%	52%	7.60	0.642	24.62	0.7	1.1×10^{-6}	3.40	47%

A definite improvement can be observed for the DSSC with CNT. Furthermore, it is evident that the short-circuit current improves more with the film than with the composite. The possible reasons for this behaviour are:

1. In the composite, only a portion of the CNTs form a Schottky junction with the TiO₂. As not all of the CNTs are in contact with the TiO₂, layering the TiO₂ and CNTs in the form of a film creates a truer Schottky barrier.
2. There are more CNTs in the composite than there are in the film. This causes more competition for light absorption between the CNTs and the dye thereby lowering the charge injection from the dye to the TiO₂. This difference in light absorption is also reflected in the difference in quantum efficiency (Figure 6-2), where it is doubled in the DSSC made with the film compared to the TiO₂/CNT composite.

The open circuit voltage (V_{oc}), found in Figure 6-1, corresponds to the amount of forward bias on the cell stemming from the Fermi level of the TiO₂ and the redox potential of the electrolyte. Adding the CNTs to the photoanode causes the Fermi level of the TiO₂ to fall towards the valence band. This formation of a Schottky junction results in a drop in the open-circuit voltage. Using the CNTs as a film, instead as part of a composite, reduces both recombination and saturation dark current, resulting in an increase in the open-circuit voltage.

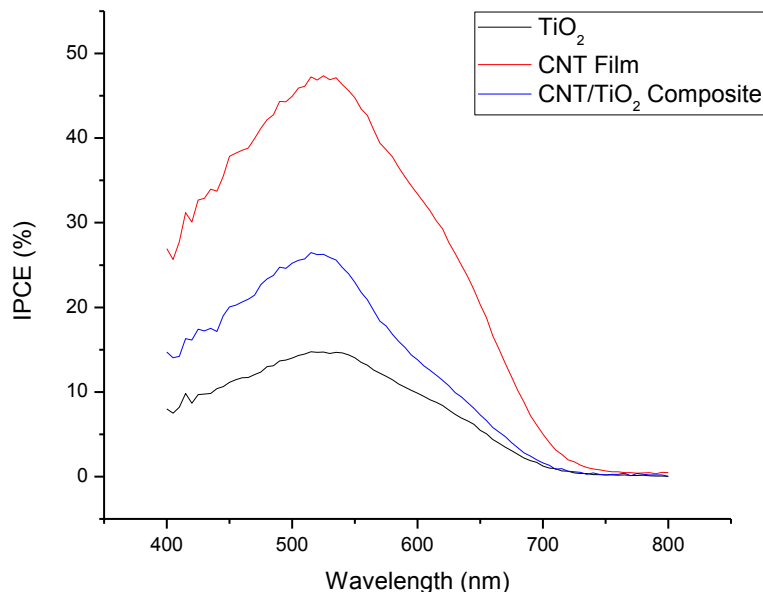

Figure 6-2: Quantum Efficiency (IPCE) performance of the DSSCs with TiO₂, CNT/TiO₂ composite, and CNT Film in the photoanode. Maximum incident photon to charge carrier efficiency for each of the DSSCs occur at 525 nm where the anode with the CNT film performs the best at almost double the photoanode with the CNT composite. The DSSCs with CNTs in the photoanode performed better than the DSSC without.

Since TiO₂ is a mesoporous structure, there are grain boundaries which have resistive effects on the DSSC. Defects in the TiO₂ will also cause a series resistance in the device. The addition of CNTs, many of which are metallic, increases the 1D transport structure of the electrons. During the preparation of the electrodes, the FTO glasses are treated with TiCl₄ (see section 3.4.1 for details). The purpose of this is to improve the adherence between the semiconducting films and the FTO glass by creating a chemical linkage. The deposition of the CNT film on the FTO glass significantly decreases this linkage and consequently decreases the adherence between the TiO₂/CNT film and the electrode. The result of this is an increase in the series resistance of the DSSC.

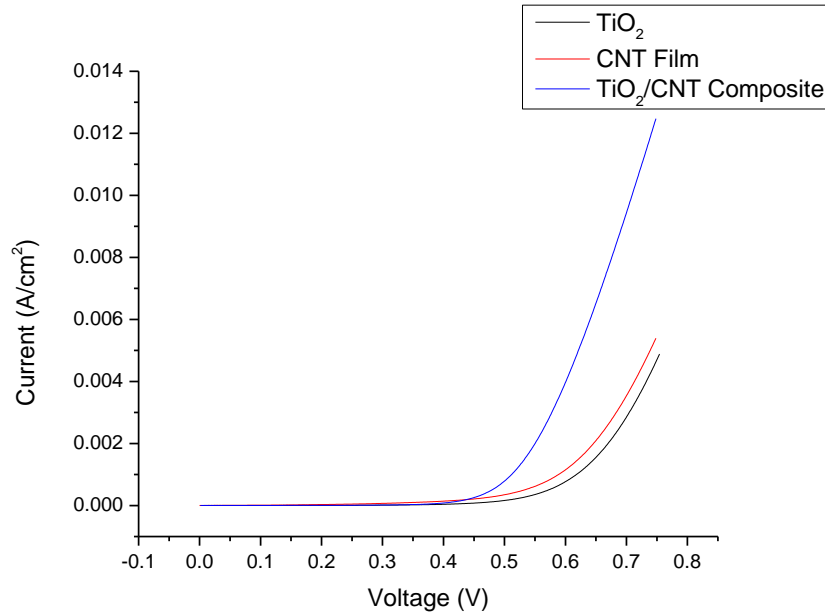

Figure 6-3: *I-V Curves measured in a dark environment. The composite shows the largest increase in dark current with an increase in voltage. The DSSCs assembled with CNT and TiO₂ layered films and only TiO₂ have relatively comparable dark current behaviour.*

The shunt resistance (R_{sh}) results in significant power loss in the cell by providing alternate paths for the current to travel. In the DSSC, a shunt will allow electrons to travel from the anode film back to the electrolyte, instead of travelling to the external circuit. In DSSCs constructed with CNTs, this means that the tri-iodide in the electrolyte is reduced from the CNTs in the photoanode, instead of the cathode. Shunt pathways were introduced by the technique used to deposit the films since it did not ensure that the CNT film will be compact. This could lead to spaces in the film where CNTs are not adequately covering the FTO electrode. The cell containing only TiO₂ in the photoanode has the highest shunt resistance; however there are still shunt pathways introduced between the conductive FTO glass and the electrolyte.

The saturation dark current (I_o), which is derived from taking the linear fit of the $\ln(\text{dark current})$ shown in Figure 6-4, is a measure of the leakage current density from the anode to the electrolyte. It is directly related to thermal excitation and recombination with the electrolyte. The kinetics is described by:

$$I_o = k[I_3^-][e^-] \quad (27)$$

where k is the kinetic constant which is based on the speed of reaction, $[I_3^-]$ is the concentration of tri-iodide, and $[e^-]$ is the concentration of electrons leaking to the electrolyte. The speed of the reaction is influenced by the number of catalyst sites causing the reduction of tri-iodide. The kinetic constant is high due to the grain boundaries and dangling bonds in the TiO_2 . However, this is compensated by the concentration of electrons being kept low by its high band gap of 3.2 eV which makes it difficult for the current to leak to the cathode. The DSSC with the composite had the highest saturation dark current due to a larger percentage of CNTs in the composite. Additionally many of the CNTs were exposed to the electrolyte. Ensuring that the CNTs be completely covered by TiO_2 is still an area of ongoing research and a priority, as the partial covering causes the composite to not behave as a real Schottky junction and produce a lower forward bias. The CNT film has the same issues as the composite in that there are CNTs exposed to the electrolyte; however the amount is much less in comparison to the composite. The incorporation of the CNTs in the form of a film creates an electronic structure closer to that of a real Schottky junction, thereby improving the forward bias and decreasing the recombination current.

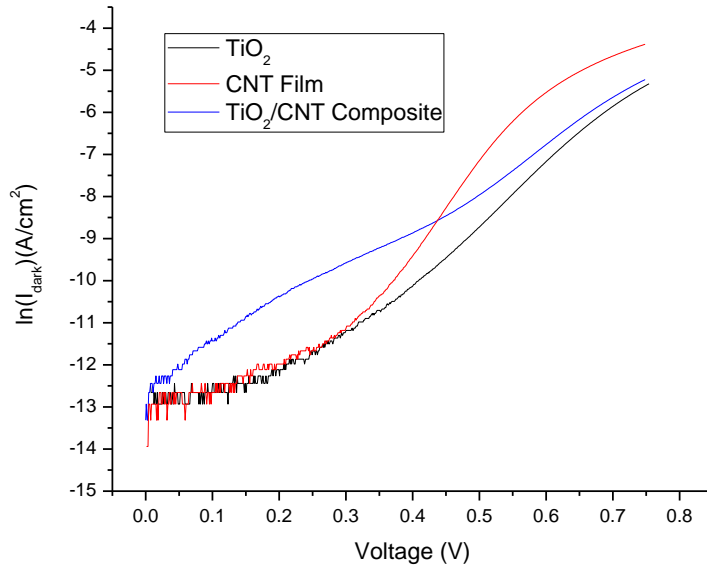

Figure 6-4: $\ln(I)$ - V Curves of DSSCs in a dark environment. Two junctions are evident in the CNT film curve due to the layering in the composition of the anode.

Another parameter that is directly influenced by the recombination in the cell is the ideality factor which is a measure of how well the device behaves like a diode. An ideal diode has an ideality factor of 1, however good solar cells typically have ideality factors between 1 and 2. DSSCs having ideality factors larger than 2 are also frequently observed. The ideality factor of the basic TiO_2 -DSSC is attributed to a higher order kinetic recombination due to electron traps and defects in the film. The anode film composed of the CNT/ TiO_2 composite is a first order kinetic mechanism which implies the electrons are travelling directly from the tubes to the electrolyte. However, the value is closer to 2 than to 1 because the Schottky barrier is not ideal resulting in tunnelling and image charge. The photoanode composed of the layered CNT and TiO_2 film has a high ideality factor which can be explained by the method used to deposit the CNT film on the electrode. The resulting CNT film was not as uniform as anticipated.

6.2 Performance of Cells with Chirality Separated SWNTs

This section discusses the results from an internal comparison between different SWNT films. The TiO₂ was switched from the hydrothermally synthesized composite to the better quality commercial P90. Table 6-2 summarizes the DSSC parameters of cells made with chirality-specific CNT films. Overall, the DSSCs did not perform as well as expected. The main reason for this is the exposure of the CNTs to the electrolyte. The films deposited in this section were much larger than the dimensions of the TiO₂ film screen-printed on top, and while there was an attempt to scratch the exposed film off of the conductive glass, care had to be taken to not ruin the electrode or FTO coating. Therefore it was not possible to scratch off all of the exposed film. In the future, depositing CNTs using a spray pyrolysis technique to coat the films, make them more compact, and have them fit the dimensions of the layered TiO₂, will significantly decrease the catalysis of the electrolyte from the anode.

While this study does not reveal the best efficiencies, it does report a trend of increasing efficiency with increased chiral selectivity and an improvement over the mixed chirality film. Furthermore, the results found in Figure 6-5 and Table 6-2 indicate which chiralities improve the performance of the anode and which do not.

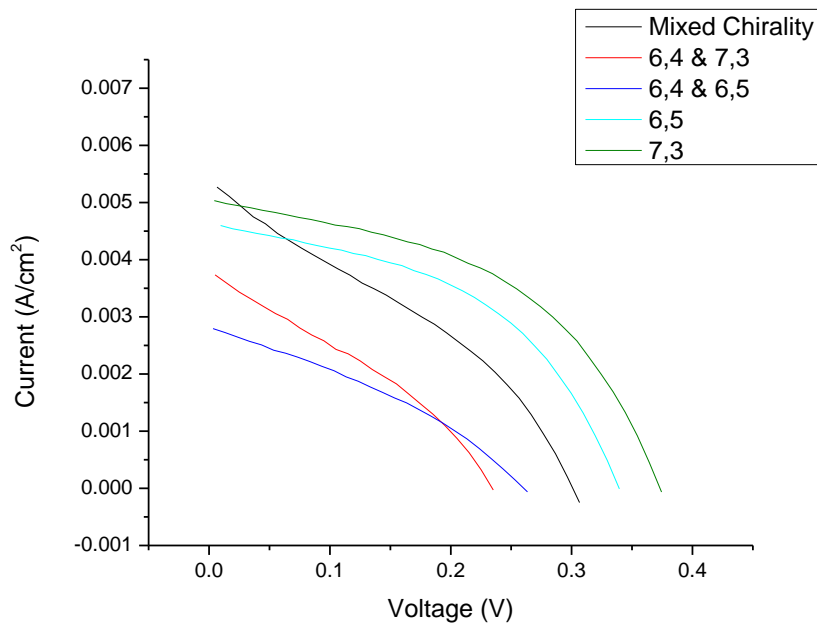

Figure 6-5: I-V Curves of DSSCs taken under an irradiance of 1 sun. DSSCs assembled with a single-chirality anode had the highest fill factor (FF) and efficiency (η).

Table 6-2: DSSC performance parameters of devices composed of chirality specific SWNT films in the photoanode.

	η	FF	I_{sc} (mA)	V_{oc} (V)	R_s (Ω)	R_{sh} (Ω)	I_o (A)	m	IPCE
Mixed	0.54%	32%	5.51	0.307	22.4	31.4	2.2×10^{-4}	3.93	7%
(7,3) & (6,4)	0.28%	30%	3.99	0.235	28.6	53.4	7.3×10^{-5}	2.80	6%
(6,5) & (6,4)	0.24%	33%	2.79	0.263	48.5	352.1	2.0×10^{-5}	2.92	8%
(6,5)	0.74%	47%	4.62	0.340	20.1	110.4	4.5×10^{-5}	2.47	12%
(7,3)	0.98%	48%	5.03	0.374	19.8	122.4	2.4×10^{-5}	2.12	15%

The open-circuit voltage shown in Figure 6-5 indicates the Fermi level position of the TiO₂ and the redox potential of the electrolyte. If the TiO₂ is brought into contact with CNTs of different bandgaps, the Fermi level of the semiconductor will shift either up or down, influencing the open circuit voltage. The mixed film has the largest variation in bandgaps, as well as metallic species. The two-chirality mixed films vary in their purity: the (7,3) & (6,4) film has a greater amount of metallic tubes than the (6,5) & (6,4) film. The single-chirality films: (6,5) and (7,3) have the highest purity in semiconducting tubes, as well as a high single-chirality purity. As reported in Table 6-3, the barrier height decreases with the amount of metallic tubes. Decreasing the barrier height increases the saturation dark current (Figure 6-6 and Figure 6-7) since more electrons can be thermally generated. The mixed film has the shortest height and the purer single-chiralities have the largest. When the TiO₂ and single-chirality film come into contact, the Fermi levels equilibrate, causing the Fermi level in the TiO₂ to shift upwards. This causes the difference between the conduction band of the TiO₂ and the redox potential of the electrolyte to become higher – thus increasing the open-circuit voltage of the DSSC.

Table 6-3: Surface area of TiO₂ films and estimated Schottky barrier heights at the FTO/TiO₂ interfaces influenced by varying chirality films.

	Surface Area (cm ²)	Schottky Barrier Height (eV)
Mixed	0.105	0.36
(7,3) & (6,4)	0.031	0.39
(6,5) & (6,4)	0.100	0.45
(6,5)	0.062	0.65
(7,3)	0.086	0.68

When a metallic and semi-conducting material comes in contact, they typically form a conventional Schottky barrier, where the Fermi level of the semiconducting material shifts to become a constant through the system. When two semiconducting materials come into contact with one another, the Fermi levels of each of the materials shift to equilibrate with one another creating a heterojunction at the interface. There are three types of junctions that could form at a semi-conductor/semi-conductor interface:

1. Straddling gap (Type I): Where the bandgap of one semiconductor is completely contained in the bandgap of the other. This is the most common heterojunction.
2. Staggered gap (Type II): The bandgaps overlap; however either the conduction band of the smaller gapped material might lie above that of the larger gapped material or its valence band might lie below.
3. Broken gap (Type III): If the staggering of the gaps becomes too extreme, they do not overlap at all.

Since the electron affinity of the TiO_2 film, or the work function of the individual single and mixed chirality films have not been found, it cannot be known exactly what kind of heterojunction is at the CNT/ TiO_2 interface in each DSSC. Furthermore, there are inevitable impurities in each of the films including vacancies and grain boundaries in the TiO_2 , and even small amounts of sodium from the surfactant used to separate the SWNTs. These impurities might cause a “pinning” of the Fermi level in the semiconductor and not a shift as predicted; they also contribute to an unknown type of barrier at the junction between the electrode and the TiO_2 .

A linear fit of the I-V curve measured in a dark environment of each DSSC (Figure 6-6) was used to estimate the barrier height and tabulated in Table 6-3.

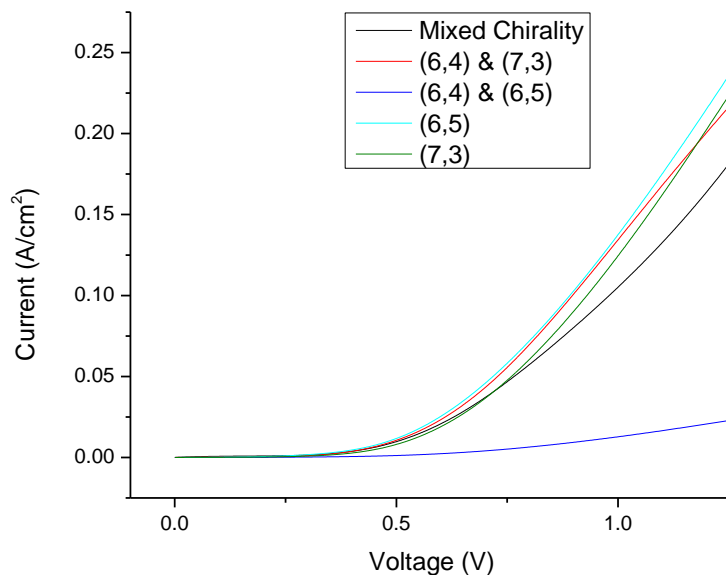

Figure 6-6: I-V Curves measured in a dark environment. The (6,5) & (6,4) chirality film produced the smallest increase in dark current with an increase in voltage due to having the highest shunt resistance

The (6,4) chirality incorporated into the dual-mixed chirality films has a comparatively larger band gap than either the (7,3) or (6,5) chiralities. The effect of the larger band gap shifts the Fermi level up, which should increase in theory the open-circuit voltage. However, the barrier height remains low because the (6,4) chirality has its Fermi level close to the conduction band of the TiO₂. The result is less charge collection and more recombination, and therefore a decreased short-circuit current and a lower open-circuit voltage. This concept of the (6,4) chirality has the same effect on the films' quantum efficiency (in Figure 6-8). The Fermi level is

too high, so the injection from the LUMO of the dye is again not favoured. Therefore it can be concluded that the (6,4) chirality is not a useful material to have in the photoanode.

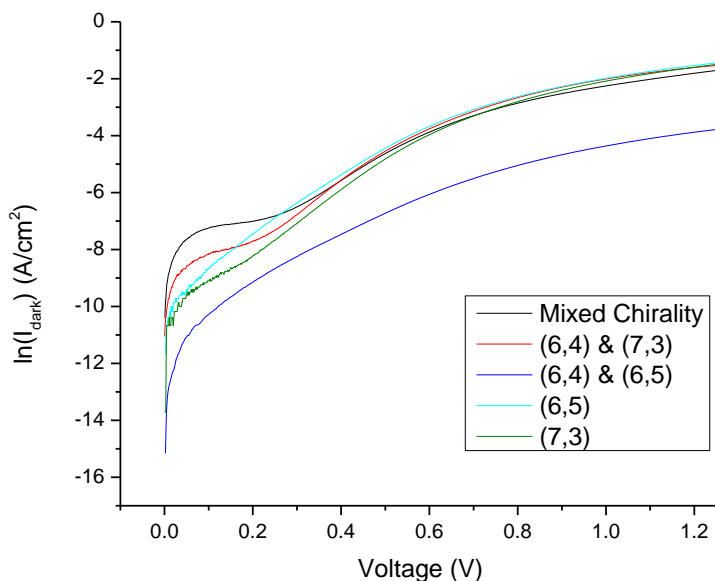

Figure 6-7: $\ln(I)$ - V Curves of DSSCs in a dark environment. Two junctions are evident in the curves due to the layering composition of the anode.

The quantum efficiency is low for the mixed chirality anode, for if the Fermi level is high (and the barrier height low), there is a smaller difference between the LUMO of the dye and the conduction band in the TiO_2 . The result is the injection of electrons from the LUMO of the dye to conduction and of the TiO_2 to be less favoured, which consequently decreases the quantum efficiency. Similarly, competition between the dye and the carbon nanotubes also decreases the quantum efficiency of the DSSC. The metallic species present in both the mixed film and the (7,3) & (6,4) film demonstrates this effect.

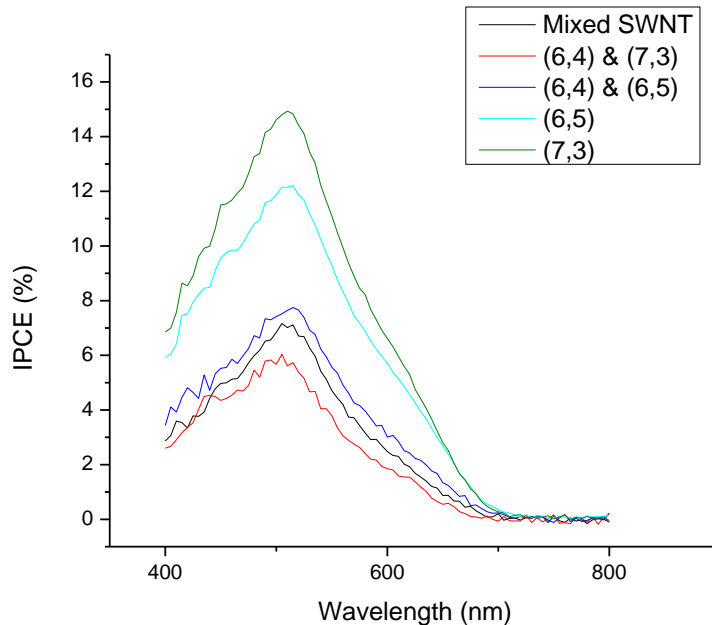

Figure 6-8: Quantum Efficiency performance of the DSSCs with mixed and single chirality films in the photoanode. Maximum incident photon to charge carrier efficiency for each of the DSSCs occurs at 515 nm where the anodes composed of single-chirality films perform the best. Films with only two chiralities perform the worst largely due to the loss of conductivity.

The metallic tubes in the mixed and (7,3) & (6,4) films are responsible for lowering the series resistance in the photoanode. Having a mixture of CNTs with different bandgaps introduces carrier traps in the material which increases the material's resistance. This is clearly observed in the (6,5) & (6,4) film, where the amount of metallic species is low but the semiconducting species with varying bandgaps is high.

In the single chirality films, the open-circuit voltage is expected to be low because the bandgap in these materials is small and the Fermi level is therefore close to the redox potential of the electrolyte. However, the barrier height in these anodes is higher, resulting in improved collection efficiency, higher quantum efficiency, and a smaller saturation dark current thereby

raising the open-circuit voltage. Since the barrier is higher, the Fermi level of the single chirality films has an energetic distance from the LUMO of the dye (See Figure 1-3). This is why there is better charge injection causing a higher short-circuit current. The better performance of the (7,3) film over the (6,5) film can be explained by the small difference in band gap between the two structures. This difference in band gap translates to less competition for photons between the (7,3) carbon nanotubes and the dye since the absorption spectrum of the dye is removed from the absorption of the (7,3) chirality (see Chapter 5 for transmittance measurements). This results in a higher short-circuit current in the DSSC with the (7,3) anode. This difference in barrier height in the (7,3) structure also results in the shunt resistance being higher as well.

The shunt resistance is lowest for the mixed chirality film due to the presence of metallic tubes causing recombination between the photoanode and counter-electrode. As discussed in chapter 4, the purity of semiconducting tubes in the (7,3) & (6,4) films is lowest and thus there are more metallic tubes than in the rest of the chirality-specific films. This is correlated to the saturation dark current and the shunt resistance. The presence of metallic tubes allows for shunt pathways for the electrons to travel and increased opportunities for recombination. The film made up mainly of (6,4) & (6,5) chiralities has the highest purity of semiconducting tubes and therefore the highest shunt resistance and lowest saturation dark current. As identified previously in Chapter 5, the conductivity of the (6,4) & (6,5) film is also the lowest. This is not only due to the absence of metallic tubes, but also to the mix of the two chiralities in the same film creating electron traps. Both (6,5) and (7,3) films have a high semiconducting nanotube purity; however they are also the most conductive out of the chiral-specific films. So while their shunt resistance is lower (with an higher saturation dark current) than the (6,5) & (6,4) mixed film, there are less

shunt pathways and less recombination than the films with more metallic tubes but yet comparably conductive.

The ideality factor is about 2 in all of the anode materials in this section. The anode resulting in a DSSC performance closest to an ideal diode is the (7,3). None of the DSSCs tested produced an ideality factor between 1 and 2, due to the exposure of CNTs to the electrolyte and the increased amount of shunt pathways.

6.3 Cathode Performance of SWNT Film (Mixed and Single Chirality)

Since carbon nanotubes catalyze the electrolyte reaction so well, experiments were done to test how CNT films of mixed and single chirality performed as counter electrodes. As a reference cell, these films were tested and compared against the conventional platinum film. Similar to previous experiments, the photoanodes consist of the commercial P90 TiO₂ and was mixed into a paste and screen printed onto the FTO glass.

As illustrated in Figure 6-9 and recorded in Table 6-4, the short circuit current is highest in the cell with the platinum (Pt) counter-electrode due to the increased conductivity of the Pt. The conductivity of the mixed film is undermined by the presence of tubes with mixed band gaps and while the (6,5) has a fairly high purity of a single chirality, it has a lower conductivity in comparison to the Pt and mixed film. The result is a decreased rate of reduction of the tri-iodide to iodide, causing a slow electron regeneration of the dye. If the rate of injection of electrons from the dye to the TiO₂ is faster than the regeneration of the dye from the electrolyte, it will become more favourable for the dye to regenerate its electrons from the TiO₂ instead. This

hinders the generation of current in the photoanode of the cell and thus lowers the short circuit current.

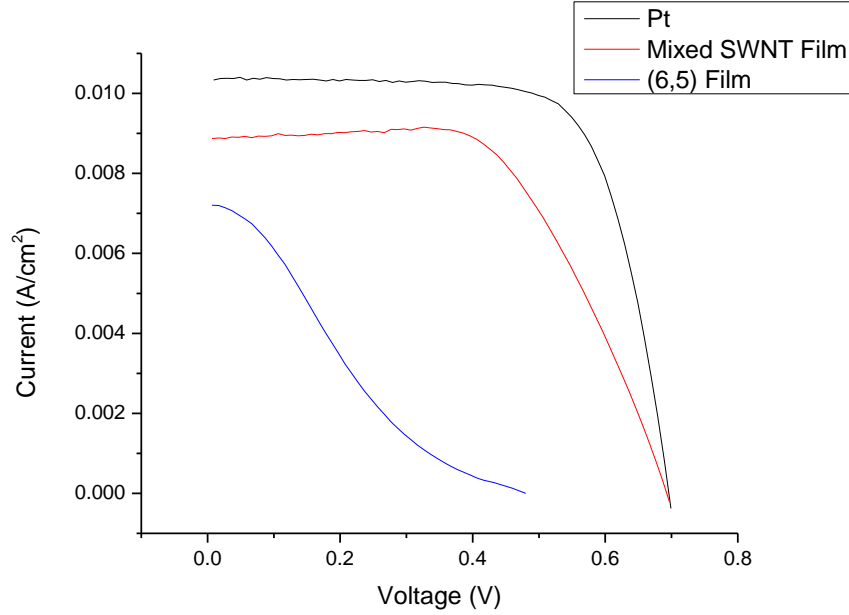

Figure 6-9: I-V Curves of DSSCs taken under an irradiance of 1 sun. The DSSC with the cathode composed of platinum displayed highest fill factor (FF) and performed with the highest efficiency (η). The tail in the (6,5) counter-electrode is due to the high amount of semi-conducting tubes thus making the contact between the film and the FTO less ohmic. The result is the formation of two junctions seen by a change in the slope of the curve.

Table 6-4: DSSC performance parameters of devices with the cathode composed of platinum, mixed chirality carbon nanotubes, and (6,5) carbon nanotubes respectively.

	η	FF	I_{sc} (mA)	V_{oc} (V)	R_s (Ω)	R_{sh} (Ω)	I_o (A)	m	IPCE
Pt	5.2%	71%	10.37	0.699	8.7	33792.1	1.3×10^{-8}	1.67	27%
Mixed	3.7%	60%	8.88	0.697	20.0	55958.1	1.1×10^{-7}	2.16	30%
(6,5)	0.73%	24%	7.25	0.417	111.1	111.0	5.7×10^{-5}	2.35	15%

The counter-electrodes composed of Pt and mixed chirality films have comparable quantum efficiency (see Figure 6-10). The discrepancy between the quantum efficiency and the short-circuit current is due to the fact that the change in efficiency does not scale linearly with power. The comparable quantum efficiency values are expected between the DSSCs with Pt and mixed films because the parameter primarily depends on the performance of the photoanode, which is composed of only TiO₂. The DSSC with the (6,5) cathode is also made up of TiO₂ in the photoanode; however the quantum efficiency is quite low in comparison to the other two cells due to the significant difference in the short-circuit current.

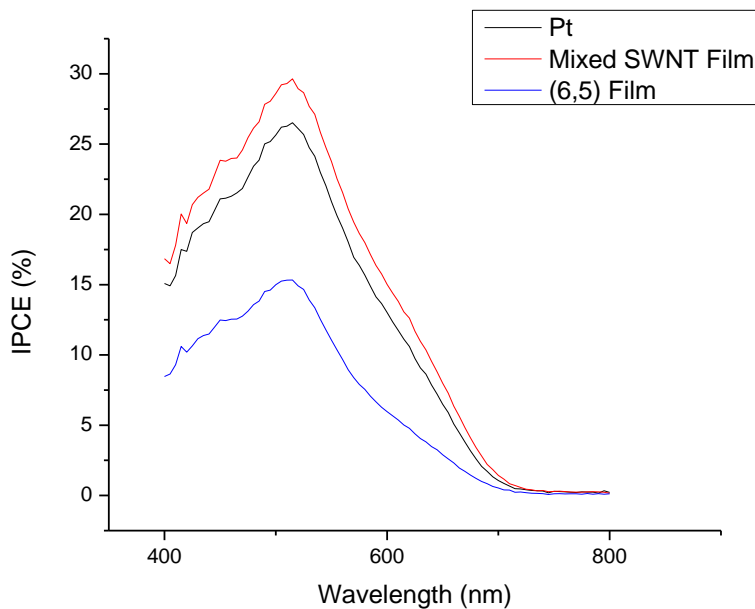

Figure 6-10: Quantum Efficiency performance of the DSSCs with platinum, mixed chirality films, and (6,5) CNT films. The maximum absorbance occurred at 515 nm with the mixed chirality counter-electrode device having the highest incident photon to conversion efficiency (IPCE) of 30%.

The open-circuit voltage is similar between the mixed film and platinum counter-electrodes indicating good electron injection from the mixed tubes to the electrolyte. The value of the open-circuit voltage is close to the thermodynamic value of approximately 0.7 V, given by the difference between the Fermi level of the TiO_2 and the redox level of the electrolyte. The (6,5) however has a much lower open-circuit voltage than the other two cells which is likely due to the high amount of saturated dark current.

There are two kinds of series resistance acting on the counter electrode:

1. The Ohmic resistance.
2. The resistance in charge transfer which does not change linearly with the voltage, and is thus not ohmic. This resistance depends on the process of electron transfer from the counter electrode to the electrolyte. The slower the transfer, the lower the short-circuit current and open-circuit voltage.

The series resistance also affects the fill factor. As the series resistance increases, more power is dissipated causing the fill factor to lower and ultimately lower the short-circuit current. There is a difference in the series resistance of the mixed and (6,5) cathodes due to the presence of semi-conducting tubes and electronic impurities. Based on this, if the mixed film and the platinum are compared, it was observed that the mixed chirality counter-electrode has a higher series resistance; but not as high as the (6,5) only film.

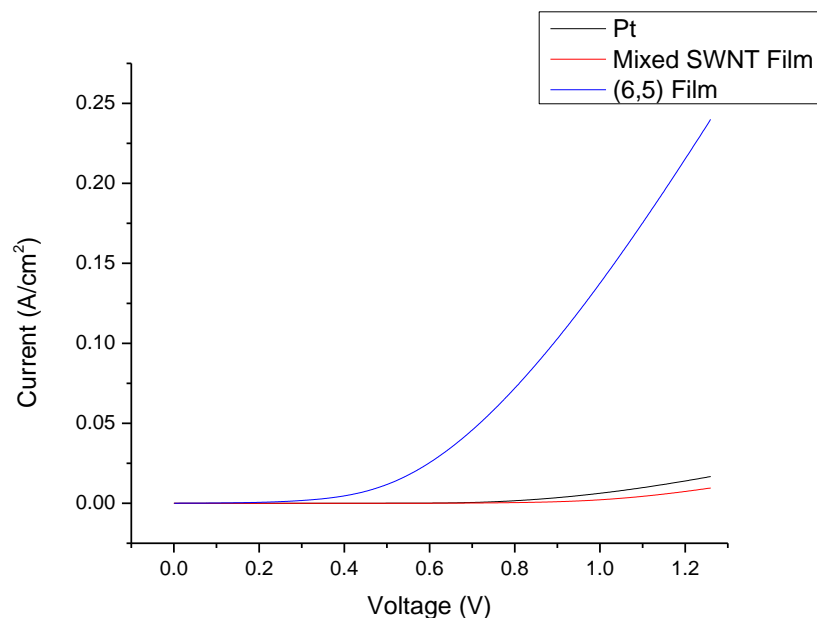

Figure 6-11: *I-V Curves measured in a dark environment. The (6,5) chirality film shows the largest increase in dark current with an increase in voltage while DSSCs assembled with platinum and mixed chiralities in the counter electrode have relatively comparable dark current behaviour.*

The shunt resistance is lowest for the DSSC assembled with a (6,5) chirality counter-electrode due to the lack of compactness in the film. As explained previously in this chapter, the deposition method used makes it hard to control the uniformity of the film. This causes some of the tubes in the counter electrode to make contact with the FTO glass in the anode creating a short and decreasing the shunt resistance.

In Table 6-4 the mixed film has a higher shunt resistance than the (6,5) film despite the similar deposition technique of each of the films. Therefore in this case there must not be a short and yet the saturated dark current is higher than the platinum electrode (see Figure 6-11). Due to the presence of semiconducting tubes in the mixed film, the electron transfer between the counter electrode and the electrolyte is not as efficient as the platinum electrode and therefore does not

catalyze the electrolyte as effectively. Again this results in a reduced rate of reduction in the tri-iodide to iodide which then negatively effects the regeneration the dye. Therefore, regardless of the high shunt resistance in the mixed film DSSC, the decreased rate in which the tri-iodide becomes reduced makes it easier for the dye to take electrons back from the TiO_2 thereby increasing the saturation dark current.

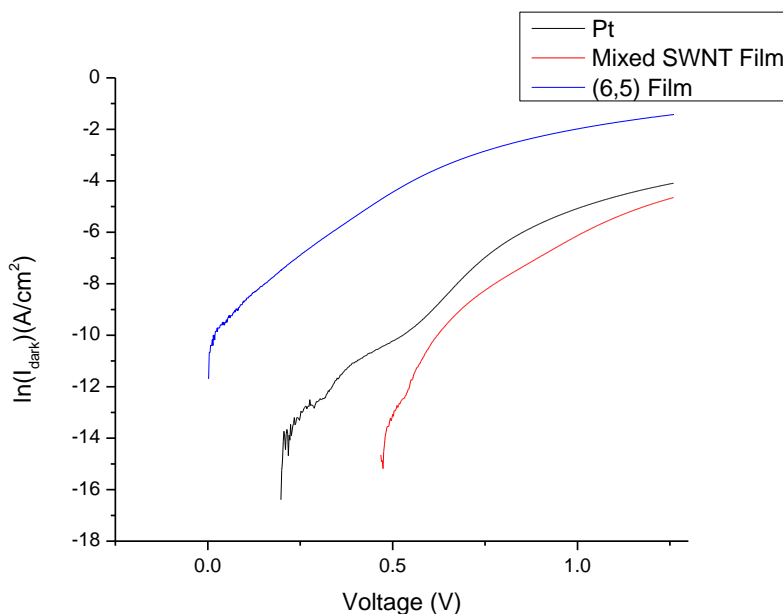

Figure 6-12: $\ln(I)$ - V Curves of DSSCs in a dark environment. The cathode composed of the (6,5) chirality film shows a low shunt resistance and a high saturated dark current.

All of the carbon nanotube films used for the counter-electrode produced DSSCs performing with an ideality factor higher than 2. While this is not ideal for a diode or solar cell, it is not unusual in a DSSC. The cathode composed of the (6,5) film had the highest ideality factor due to the short between the film and the FTO anode increasing recombination. This is consistent with the high saturated dark current, and the low shunt resistance. Finally, the DSSC

with the platinum counter-electrode had the better ideality factor of between 1 and 2. This could again be attributed to the higher rate of reduction two the electrolyte.

Chapter 7

Conclusion and Future Work

Samples of HiPCO SWNTs of enriched chirality were prepared using the procedure originally outlined in a 2011 paper by Liu *et al.* and modified for this work in order to obtain a more efficient selection of high purity single chiralities. Enriched tubes of (6,5) and (7,3) at purities 93 and 86% were obtained in a single pass. The approach used was dependent on the ratio of gel to CNTs, which varied in each batch prepared. The procedure was adjusted for each batch. The versatility of this separation technique suggests the possibility of separating small diameter and semiconducting “homemade” CNTs. Research has suggested, through atomic force microscopy data, that after sonication there is little difference in length among the different (n, m) nanotubes; consequently, length difference of the CNTs was assumed not to be a factor in chirality separation.

The different chiralities were tested by preparing DSSC with CNT/ TiO₂ composites. CNTs deposited in a thin film layer configuration were also tested within a DSSC device. An improved performance in the film over the composite was observed and attributed to decreased competition with the dye, less exposure to the electrolyte, and increased behaviour as a Schottky barrier. Additionally there was an improvement in the performance of DSSCs with photoanodes of a single chirality. Using a single-chirality in the photoanode allowed us to tune the Schottky barrier height so that there was a larger difference between the LUMO of the dye and the conduction band in the TiO₂. This process promotes electron injection from the dye to the TiO₂. The end result was an increased forward bias and less recombination. Since the single chirality

films only absorbed light at a single wavelength and did not overlap the maximum absorbance of the dye, there was little competition between the single-chirality SWNT films and the dye. Future work includes measuring the work function of each of the films to better determine the type of heterojunction at the CNT/TiO₂ interface.

As there was a significant catalyzing effect from the CNTs on the electrolyte, films with both mixed and single-chirality CNTs were tested as the counter-electrode of the DSSC. The mixed film, with the presence of metallic species, performed well as the DSSC counter-electrode, achieving better quantum efficiency than platinum. However, the fill factor and short circuit current was less than that of the Pt electrode translating into decreased DSSC performance. To improve the behaviour of CNTs in the counter electrode, future work will include separation of metallic from semiconducting tubes to deposit only metallic tubes as a cathode film.

The work presented in this study required the deposition of a CNT film directly on FTO glass, treated with TiCl₄, followed by screen-printing of a TiO₂ layer on top of the deposited film. Later work will include the deposition of a thin blocking layer of TiO₂ to protect the nanotube film from recombination with the electrolyte. There are numerous ways this can be achieved including atomic layer deposition, metal-organic chemical vapour deposition, or spray pyrolysis. Using spray pyrolysis as a CNT deposition method may also produce more compact films of differing areas adapted to the dimensions of the TiO₂ film, reducing contact between the CNT film and the electrolyte.

References:

- [1] United Nations, Department of Economic and Social Affairs, Population Division. World Population Prospects: The 2D12 Revision, Volume I: Comprehensive Tables; New York, NY, 2013.
- [2] International Energy Agency. World Energy Outlook 2013; OECD/IEA: Paris, 2013
- [3] Brown, Lester R. Plan B 3.0: Mobilizing to Save a Civilization; W.W. Norton & Company Inc.: New York, NY, 2008; pp 30-34.
- [4] Moriarty, P Honnery, D. What is the Global Potential for Renewable Energy? Renewable and Sustainable Energy Reviews, 16(1):244-252, 2012.
- [5] International Energy Agency. Technology Roadmap: Solar Photovoltaic Energy; OECD/IEA: Paris, 2014.
- [6] In Energy and Mines Ministers' Conference; Canada - A Global Leader in Renewable Energy: Enhancing Collaboration on Renewable Energy Technologies; 2013.
- [7] Vandeligt, K.; Pelland, S.; Poissant, Y. *Assessment of the Environmental Performance of Solar Photovoltaic Technologies*; Environment Canada, 2012.
- [8] Sze, S. *Semiconductor devices, physics and technology*; John Wiley and Sons (WIE): United States, 1985.
- [9] Jenny, N. *The physics of solar cells*; 1st ed.; Distributed by World Scientific Pub. Co.: United Kingdom, 2003.
- [10] <http://hyperphysics.phy-astr.gsu.edu/hbase/solids/imgsol/bias8.gif> (accessed Jan 6, 2015).
- [11] Cataldo, S.; Salice, P.; Menna, E.; Pignataro, B. *Energy & Environmental Science* **2012**, *5*.
- [12] Grätzel, M. *Journal of Photochemistry and Photobiology A: Chemistry* **2004**, *164*, 3–14.
- [13] Tachibana, Y.; Moser, J.; Grätzel, M.; Klug, D.; Durrant, J. *The Journal of Physical Chemistry* **1996**, *100*, 20056–20062.
- [14] In *Handbook of photovoltaic science and engineering*; John Wiley & Sons Inc: United States, 2003.
- [15] Hardin, B.; Snaith, H.; McGehee, M. *Nature Photonics* **2012**, *6*, 162–169.
- [16] Haque, S.; Tachibana, Y.; Willis, R.; Moser, J.; Grätzel, M.; Klug, D.; Durrant, J. *The Journal of Physical Chemistry B* **2000**, *104*, 538–547.

- [17] Tachibana, Y.; Haque, S.; Mercer, I.; Moser, J.; Klug, D.; Durrant, J. *The Journal of Physical Chemistry B* **2001**, *105*, 7424–7431.
- [18] Wang, P.; Zakeeruddin, S.; Moser, J.-E.; Grätzel, M. *The Journal of Physical Chemistry B* **2003**, *107*, 13280–13285.
- [19] Wang, Z.-S.; Kawauchi, H.; Kashima, T.; Arakawa, H. *Coordination Chemistry Reviews* **2004**, *248*, 1381–1389.
- [20] Carp, O.; Huisman, C.L.; Reller, A.; *Progress in Solid State Chemistry* **2004**, *32*, 33–177.
- [21] Leary, R.; Westwood, A. *Carbon* **2011**, *49*, 741–772.
- [22] Li, G.; Richter, C.; Milot, R.; Cai, L.; Schmuttenmaer, C.; Crabtree, R.; Brudvig, G.; Batista, V. *Dalton Transactions* **2009**.
- [23] Du, L.; Furube, A.; Hara, K.; Katoh, R.; Tachiya. *The Journal of Physical Chemistry C* **2010**, *114*, 8135–8143.
- [24] Woan, K.; Pyrgiotakis, G.; Sigmund, W.; *Advanced Materials* **2009**, *21*, 2233–2239.
- [25] Dresselhaus, M.; etc.; Dresselhaus. *Science of Fullerenes and Carbon Nanotubes: Their Properties and Applications*; Elsevier Science & Technology Books: United States, 1996.
- [26] Kumar, M.; Ando, Y. *J. Nanosci. Nanotechnol.* **2010**, *10*, 3739–3758.
- [27] Tessonnier, J.-P.; Su, D. S. *ChemSusChem* **2011**, *4*, 824–847.
- [28] Iijima, S. *Nature* **1991**, *354*, 56–58.
- [29] Saito, Y.; Nishikubo, K.; Kawabata, K.; Matsumoto, T. *Journal of Applied Physics* **1996**, *80* (5).
- [30] Ebbesen, T.; Ajayan, P. *Nature* **1992**, *358*, 220–222.
- [31] Zhao, X.; Ohkohchi, M.; Inoue, S.; Suzuki, T.; Kadoya, T.; Ando, Y. *Diamond and Related Materials* **2006**, *15*, 1098–1102.
- [32] Guo; Nikolaev; Thess; Colbert, D. T.; Smalley, R. E. *Chemical Physics Letters* **1995**, *243*, 49–54.
- [33] Journet, C.; Picher, M.; Jourdain, V. *Nanotechnology* **2012**, *23*.
- [34] In *Understanding Carbon Nanotubes: From Basics to Applications*; Loiseau, A., Ed.; Springer-Verlag Berlin and Heidelberg GmbH & Co. K: Germany; pp. 55–58.
- [35] Thess; Lee; Nikolaev; Dai; Petit; Robert; Xu; Lee, Y.; Kim, S.; Rinzler, A.; Colbert, D.; Scuseria, G.; Tomanek; Fischer, J.; Smalley, R. *Science* **1996**, *273*, 483–487.
- [36] Rao, A. *Science* **1997**, *275*, 187–191.

- [37] Li, W.; Xie, S.; Qian, L.; Chang, B.; Zou, B.; Zhou, W.; Zhao, R.; Wang, S. *Science* **1996**, *274*, 1701–1703.
- [38] Presek, J.; Drbohlavova, J.; Chomoucka, J.; Hubalek, J. In *Carbon Nanotubes: Synthesis & Properties*; Mishra, A. K., Ed.; Nova Science Publishers, Inc.: United States, 2011.
- [39] Kumar, M. *Carbon Nanotubes - Synthesis, Characterization, Applications* **2011**.
- [40] Huang, S.; Cai, X.; Liu, J. *Journal of the American Chemical Society* **2003**, *125*, 5636–5637
- [41] Liu, H.; Takagi, D.; Chiashi, S.; Homma, Y. *Nanotechnology* **2009**, *20*.
- [42] Deck, C.; McKee, G.; Vecchio, K. *Journal of Electronic Materials* **2006**, *35*.
- [43] Cumings, J.; Mickelson, Z.; Zettl, H. *Solid State Communications* **2003**, *126*, 359–362.
- [44] Hayashi, Y.; Fukumura, T.; Odani, K.; Matsuba, T.; Utsunomiya, R. *Thin Solid Films* **2011**, *518*, 3506–3508.
- [45] Du, G.; Zhou, Y.; Xu, B. *Materials Characterization* **2010**, *61*, 427–432.
- [46] Lim, S. H.; Luo, Z.; Shen, Z.; Lin, J. *Nanoscale Research Letters* **2010**, *5*, 1377–1386.
- [47] Nikolaev, P.; Bronikowski, M.; Bradley, R. K.; Rohmund, F.; Colbert, D.; Smith, K. S.; Smalley, R. *Chemical Physics Letters* **1999**, *313*, 91–97.
- [48] Bronikowski, M.; Willis, P.; Colbert, D.; Smith, K.; Smalley, R. *Journal of Vacuum Science & Technology A: Vacuum, Surfaces, and Films* **2001**, *19*.
- [49] Ci, L.; Xie, S.; Tang, D.; Yan, X.; Li, Y.; Liu, Z.; Zou, X.; Zhou, W.; Wang, G. *Chemical Physics Letters* **2001**, *349*, 191–195.
- [50] Tang, Z. *Science* **2001**, *292*, 2462–2465.
- [51] Strano, M.; Huffman, C.; Moore, V.; O’Connell, M.; Haroz, E.; Hubbard, J.; Miller, M.; Rialon, K.; Kittrell, C.; Ramesh, S.; Hauge, R.; Smalley, R. *The Journal of Physical Chemistry B* **2003**, *107*, 6979–6985.
- [52] Kataura; Kumazawa; Maniwa; Umezu; Suzuki; Ohtsuka; Achiba. *Synthetic Metals* **1999**, *103*, 2555–2558.
- [53] Meyyappan. *Carbon Nanotubes: Science and Applications*; CRC Press Inc: United States, 2004.
- [54] Belin; Epron. *Materials Science and Engineering: B* **2005**, *119*, 105–118.
- [55] Bachilo, S.; Strano, M.; Kittrell, C.; Hauge, R.; Smalley, R.; Weisman, B.R. *Science* **2002**, *298*, 2361–2366.
- [56] Belin, T.; Epron, F. *Materials Science and Engineering: B* **2005**, *119* (2), 105–118.

- [57] Tromp, R.; Afzali; Freitag; Mitzi, D.; Chen, Z. *Nano Letters* **2008**, *8*, 469–472.
- [58] Yanagi, K. In *Carbon Nanotubes and Graphene*; Tanaka, K.; Iijima, S., Eds.; Elsevier: United Kingdom, 2014; pp. 19–38.
- [59] Gupta, D.; Singh, N.; Gajbhiye, N.; Choudhary, B. *Emerging Materials Research* **2013**, *2*, 299–337.
- [60] Ajayan, P.; Ebbesen, T.; Ichihashi; Iijima; Tanigaki; Hiura. *Nature* **1993**, *362*, 522–525.
- [61] Dyke, C.; Tour, J. *Journal of the American Chemical Society* **2003**, *125*, 1156–1157.
- [62] Hirsch, A. *Angewandte Chemie International Edition* **2002**, *41*.
- [63] Peng-Cheng; Siddiqui, N.; Marom, G.; Kim, J.-K. *Composites Part A: Applied Science and Manufacturing* **2010**, *41*, 1345–1367.
- [64] Tobias, G.; Mendoza, E.; Ballesteros, B. In *Encyclopedia of nanotechnology*; Bhushan, B., Ed.; Springer Netherlands: Netherlands, 2012; pp. 911–919.
- [65] Nakashima, N.; Tomonari, Y.; Murakami, H. *Chemistry Letters* **2002**, 638–638.
- [66] Steinmetz, J.; Kwon, S.; Lee, H.-J.; Abou-Hamad, E.; Almairac, R.; Goze-Bac, C.; Kim, H.; Park, Y.-W. *Chemical Physics Letters* **2006**, *431*, 139–144.
- [67] Ehli, C.; Rahman, G. A.; Jux, N.; Balbinot, D.; Guldi, D.; Paolucci, F.; Marcaccio, M.; Paolucci, D.; Melle-Franco, M.; Zerbetto, F.; Campidelli, S.; Prato, M. *Journal of the American Chemical Society* **2006**, *128*, 11222–11231.
- [68] Tu, X.; Manohar, S.; Jagota, A.; Zheng, M. *Nature* **2009**, *460*, 250–253.
- [69] Arnold, M.; Stupp, S.; Hersam, M. *Nano Letters* **2005**, *5*, 713–718.
- [70] Zheng, M.; Jagota, A.; Semke, E.; Diner, B.; Mclean, R.; Lustig, S.; Richardson, R.; Tassi, N. *Nature Materials* **2003**, *2*, 338–342.
- [71] Wang; Shan, H.; Hauge, R.; Pasquali, M.; Smalley, R. *The Journal of Physical Chemistry B* **2007**, *111*, 1249–1252.
- [72] Nikolaev, P. *ChemInform* **2004**, *35*.
- [73] Bettinger, H. *The Journal of Physical Chemistry B* **2005**, *109*, 6922–6924.
- [74] Simmons, J.; Nichols, B.; Baker, S.; Marcus, M.; Castellini, O.; Lee, C.-S.; Hamers, R.; Eriksson, M. *The Journal of Physical Chemistry B* **2006**, *110*, 7113–7118.
- [75] Osorio, A. G.; Silveira, I. C. L.; Bueno, V. L.; Bergmann, C. P. *Applied Surface Science* **2008**, *255*, 2485–2489.
- [76] Ziegler, K.; Gu, Z.; Shaver, J.; Chen, Z.; Flor, E.; Schmidt, D.; Chan, C.; Hauge, R.; Smalley, R. *Nanotechnology* **2005**, *16*, 539–544.

- [77] J. Zhang, H. Zou, Q. Quan, Y. Yang, Q. Li, Z. Liu, X. Guo, Z. Du, *J. Phys. Chem. B* **2003**, *107*, 3712-3718.
- [78] Ng, C. M.; Manickam, S. *Chemical Physics Letters* **2013**, *557*, 97–101.
- [79] N. Chopra, M. Majumder, B. J. Hinds, *Adv. Funct. Mater.* **2005**, *15*, 858-864.
- [80] Jung, M.-S.; Jung, S.-O.; Jung, D.-H.; Ko, Y. K.; Jin, Y. W.; Kim, J.; Jung, H.-T. *The Journal of Physical Chemistry B* **2005**, *109*, 10584–10589.
- [81] McDonald, T. J.; Blackburn, J. L.; Metzger, W. K.; Rumbles; Heben, M. J. *Journal of Physical Chemistry C* **2007**, *111*, 17894–17900.
- [82] Schmidt, G.; Gallon, S.; Esnouf, S.; Bourgoïn, J.-P.; Chenevier, P. *Chemistry - A European Journal* **2009**, *15*, 2101–2110.
- [83] Price, K.; Tour, J. *Journal of the American Chemical Society* **2006**, *128*, 12899–12904.
- [84] Strano, M. *Science* **2003**, *301*, 1519–1522.
- [85] Strano, M. *Journal of the American Chemical Society* **2003**, *125*, 16148–16153.
- [86] Kamaras. *Science* **2003**, *301*, 1501–1501.
- [87] Hu, H.; Zhao, B.; Hamon, M.; Kamaras, K.; Itkis, M.; Haddon, R. *Journal of the American Chemical Society* **2003**, *125*, 14893–14900.
- [88] An, K. H.; Park, J. S.; Yang, C.-M.; Jeong, S. Y.; Lim, S. C.; Kang, C.; Son, J.-H.; Jeong, M. S.; Lee, Y. H. *Journal of the American Chemical Society* **2005**, *127*, 5196–5203.
- [89] Yang, C.-M.; Park, J. S.; An, K. H.; Lim, S. C.; Seo, K.; Kim, B.; Park, K. A.; Han, S.; Park, C. Y.; Lee, Y. H. *The Journal of Physical Chemistry B* **2005**, *109*, 19242–19248.
- [90] An, K. H.; Yang, C.-M.; Lee, J. Y.; Lim, S. C.; Kang, C.; Son, J.-H.; Jeong, M. S.; Lee, Y. H. *Journal of Electronic Materials* **2006**, *35*, 235–242.
- [91] Ménard-Moyon, C.; Izard, N.; Doris, E.; Mioskowski, C. *Journal of the American Chemical Society* **2006**, *128*, 6552–6553.
- [92] O’Connell, M. *Science* **2002**, *297*, 593–596.
- [93] Green, A.; Hersam, M. *Materials Today* **2007**, *10*, 59–60.
- [94] Green, A.; Hersam, M. *Advanced Materials* **2011**, *23*, 2127–2127.
- [95] Arnold, M.; Green, A.; Hulvat, J.; Stupp, S.; Hersam, M. *Nature Nanotechnology* **2006**, *1*, 60–65.
- [96] Zhu; Crochet; Arnold, M. S.; Hersam, M. C.; Ulbricht; Resasco; Hertel. *Journal of Physical Chemistry C* **2007**, *111*, 3831–3835.

- [97] Yanagi, K.; Iitsuka, T.; Fujii, S.; Kataura, H. *The Journal of Physical Chemistry C* **2008**, *112*, 18889–18894.
- [98] Zhao, P.; Einarsson, E.; Xiang, R.; Murakami, Y.; Maruyama, S. *The Journal of Physical Chemistry C* **2010**, *114*, 4831–4834.
- [99] Doorn, S.; Fields, R.; Hu, H.; Hamon, M.; Haddon, R.; Selegue, J.; Majidi, V. *Journal of the American Chemical Society* **2002**, *124*, 3169–3174.
- [100] Doorn, S.; Strano, M.; O'Connell, M.; Haroz, E.; Rialon, K.; Hauge, R.; Smalley, R. *The Journal of Physical Chemistry B* **2003**, *107*, 6063–6069.
- [101] Krupke, R.; Hennrich, F.; Loehneysen, H.; Kappes, M. *ChemInform* **2003**, *34*.
- [102] Shin, D. H.; Kim, J.-E.; Shim, H. C.; Song, J.-W.; Yoon, J.-H.; Kim, J.; Jeong, S.; Kang, J.; Baik, S.; Han, C.-S. *Nano Letters* **2008**, *8*, 4380–4385.
- [103] Peng, H.; Alvarez, N.; Kittrell, C.; Hauge, R.; Schmidt, H. *Journal of the American Chemical Society* **2006**, *128*, 8396–8397.
- [104] Sviridov. *Clinical Chemistry* **2006**, *52*, 389–397.
- [105] Moshhammer, K.; Hennrich, F.; Kappes, M. *Nano Research* **2009**, *2*, 599–606.
- [106] Liu, H.; Nishide, D.; Tanaka, T.; Kataura, H. *Nature Communications* **2011**, *2*.
- [107] Jain, R.; Howden, R.; Tvrdy, K.; Shimizu, S.; Hilmer, A.; McNicholas, T.; Gleason, K.; Strano, M. *Advanced Materials* **2012**, *24*, 4436–4439.
- [108] Duan, W. H.; Wang, Q.; Collins, F. *Chemical Science* **2011**, *2*.
- [109] Littlejohn, D. *Analytica Chimica Acta* **1994**, *297*, 466–468.
- [110] Kataura, H.; Kumazawa, Y.; Maniwa, Y.; Umezu, I.; Suzuki, S.; Ohtsuka, Y.; Achiba, Y. *Synthetic Metals* **1999**, *103*, 2555–2558.
- [111] Landi, B. J.; Ruf, H. J.; Worman, J. J.; Raffaele, R. P. *The Journal of Physical Chemistry B* **2004**, *108*, 17089–17095.
- [112] Detriche, S.; Nagy, J. B.; Mekhalif, Z.; Delhalle, J. *Journal of Nanoscience and Nanotechnology* **2009**, *9*, 6015–6025.
- [113] Itkis, M. E.; Niyogi, S.; Meng, M. E.; Hamon, M. A.; Hu, H.; Haddon, R. C. *Nano Letters* **2002**, *2*, 155–159.
- [114] Usrey, M. L.; Chaffee, A.; Jeng, E. S.; Strano, M. S. *The Journal of Physical Chemistry C* **2009**, *113*, 9532–9540.
- [115] Pacheco, M with Correa, J. D.; Antônio J R da Silva. *Journal of Physics: Condensed Matter* **2010**, *22*.

- [116] Bergin, S. D.; Sun, Z.; Streich, P.; Hamilton, J.; Coleman, J. N. *The Journal of Physical Chemistry C* **2010**, *114*, 231–237.
- [117] Pavia, D. L.; Lampman, G. M.; Kriz, G. S. *Introduction to spectroscopy*; 3rd ed.; Harcourt College Publishers: United States, 2000.
- [118] Atkins, P. W. *The elements of physical chemistry*; Oxford; Oxford University Press, 1992: United Kingdom, 1992.
- [119] Skoog, D. A.; West, D. M.; Holler, J. F. *Principles of instrumental analysis*; Wadsworth Publishing Co Inc: United States, 1992.
- [120] *Comprehensive Analytical Chemistry* **2001**, 285–331.
- [121] Singh, P.; Campidelli, S.; Giordani, S.; Bonifazi, D.; Bianco, A.; Prato, M. *Chemical Society Reviews* **2009**, 38.
- [122] Burghard, M. *Surface Science Reports* **2005**.
- [123] Eklund, P. C.; Holden, J. M.; Jishi, R. A. *Carbon* **1995**, *33*, 959–972.
- [124] Dresselhaus, M. S.; etc.; Dresselhaus, G. *Science of Fullerenes and Carbon Nanotubes: Their Properties and Applications*; Elsevier Science & Technology Books: United States, 1996.
- [125] Yang, C.; Hu, X.; Zhang, Y. *2006 1st IEEE International Conference on Nano/Micro Engineered and Molecular Systems* **2006**.
- [126] Peng, Y.; Liu, H. *Industrial & Engineering Chemistry Research* **2006**, *45*, 6483–6488.
- [127] Zhang, J.; Zou, H.; Qing, Q.; Yang, Y.; Li, Q.; Liu, Z.; Guo, X.; Du, Z. *The Journal of Physical Chemistry B* **2003**, *107*, 3712–3718.
- [128] Jorio, A.; Pimenta, M. A.; Filho, A. S. G.; Saito, R.; Dresselhaus, G.; Dresselhaus, M. S. *New Journal of Physics* **2003**, *5*, 139–139.
- [129] <http://www.ijvs.com/volume1/edition5/section1.html> (accessed Feb 9, 2015).
- [130] Kataura, H.; Kumazawa, Y.; Maniwa, Y.; Umezumi, I.; Suzuki, S.; Ohtsuka, Y.; Achiba, Y. *Synthetic Metals* **1999**, *103*, 2555–2558.
- [131] Cheng, Q.; Debnath, S.; Gregan, E.; Byrne, H. J. *physica status solidi (b)* **2008**, *245*, 1947–1950.
- [132] Nair, N.; Usrey, M. L.; Kim, W.-J.; Braatz, R. D.; Strano, M. S. *Analytical Chemistry* **2006**, *78*, 7689–7696.

- [133] Yu, Z.; Brus, L. *The Journal of Physical Chemistry B* **2001**, *105*, 1123–1134.
- [134] Skoog, D. A.; West, D. M. *Principles of instrumental analysis*; Saunders College Pub.: United Kingdom, 1985.
- [135] Newbury, D. E.; Williams, D. B. *Acta Materialia* **2000**, *48*, 323–346.
- [136] In *Physical methods for materials characterisation*; Institute of Physics Publishing: United Kingdom, 2003.
- [137] Belin, T.; Epron, F. *Materials Science and Engineering: B* **2005**, *119*, 105–118.
- [138] Hou, P.-X.; Liu, C.; Cheng, H.-M. *Carbon* **2008**, *46*, 2003–2025.
- [139] Clark, R. J. H.; Hester, R. E. *Spectroscopy of surfaces*; Chichester; Wiley, c1988.: United Kingdom, 1988.
- [140] Dillon, E. P.; Crouse, C. A.; Barron, A. R. *ACS Nano* **2008**, *2*, 156–164.
- [141] Park, S.-G.; Kim, H.-I.; Yang, J.-J.; Kim, H.-J. *ECS Transactions* **2008**.
- [142] Wepasnick, K. A.; Smith, B. A.; Bitter, J. L.; Fairbrother, H. D. *Analytical and Bioanalytical Chemistry* **2010**, *396*, 1003–1014.
- [143] Chen, X.; Liu, L.; Liu, Z.; Marcus, M. A.; Wang, W.-C.; Oyler, N. A.; Grass, M. E.; Mao, B.; Glans, P.-A.; Yu, P. Y.; Guo, J.; Mao, S. S. *Scientific Reports* **2013**.
- [144] Chen, X.; Mao, S. S. *ChemInform* **2007**, *38*.
- [145] Atkins, P. W. *The elements of physical chemistry*; Oxford; Oxford University Press, 1992: United Kingdom, 2009.
- [146] Goldstein, J.; Newbury, D.; Joy, D.; Lyman, C.; Echlin, P. *Scanning electron microscopy and x-ray microanalysis*; 3rd ed.; Kluwer Academic/Plenum Publishers: New York, NY, 2002.
- [147] Orlov, A.; Jefferson, D. A.; Macleod, N.; Lambert, R. M. *Catalysis Letters* **2004**, *92*, 41–47.
- [148] Okpalugo, T. I. T.; Papakonstantinou, P.; Murphy, H.; McLaughlin, J.; Brown, N. M. D. *Carbon* **2005**, *43*, 153–161.
- [149] Arepalli, S.; Nikolaev, P.; Gorelik, O.; Hadjiev, V. G.; Holmes, W.; Files, B.; Yowell, L. *Carbon* **2004**, *42*, 1783–1791.

- [150] Arai, Y. *Chemistry of powder production*; Springer-Verlag New York, LLC: United Kingdom, 2008.
- [151] Cullity, B. D.; Stock, S. R. *elements of x ray diffraction*; 3rd ed.; prentice hall: United States, 2001.
- [152] Eskelinen, P. *Journal of Solid State Chemistry* **1992**, *100*, 356–362.
- [153] Heuer, J. P. *Scanning* **1992**, *14*, 365–365.
- [154] Gregg, S. J.; Sing, K. S. W. *Adsorption, surface area, and porosity*; London ; Academic Press, 1982.: United States, 1982.
- [155] Brunauer, S.; Emmett, P. H.; Teller, E. *Journal of the American Chemical Society* **1938**, *60*, 309–319.
- [156] *Choice Reviews Online* **2005**, *42*, 42–5288.
- [157] Jenny, N. *The physics of solar cells*; 1st ed.; Distributed by World Scientific Pub. Co.: United Kingdom, 2003.
- [158] Wurfel, P.; Wurfel, U. *Physics of Solar Cells: From Basic Principles to Advanced Concepts*; 2nd ed.; Wiley, John & Sons, Incorporated: Germany, 2009.
- [159] Tvrdy, K.; Jain, R. M.; Han, R.; Hilmer, A. J.; McNicholas, T. P.; Strano, M. S. *ACS Nano* **2013**, *7*, 1779–1789.
- [160] Muduli, S.; Lee, W.; Dhas, V.; Mujawar, S.; Dubey, M.; Vijayamohanan, K.; Han, S.-H.; Ogale, S. *ACS Applied Materials & Interfaces* **2009**, *1*, 2030–2035.
- [161] Kern, W.; Puotinen, D. A. *RCA Rev.* **1970**, *31*.
- [162] Wu, Z. *Science* **2004**, *305*, 1273–1276.
- [163] Hennrich, F.; Lebedkin, S.; Malik, S.; Tracy, J.; Barczewski, M.; Rösner, H.; Kappes, M. *Physical Chemistry Chemical Physics* **2002**, *4*, 2273–2277.
- [164] Ito, S.; Chen, P.; Comte, P.; Nazeeruddin, M. K.; Liska, P.; Péchy, P.; Grätzel, M. *Progress in Photovoltaics: Research and Applications* **2007**, *15*, 603–612.
- [165] Chen, L.; Zhang, B.-L.; Qu, M.-Z.; Yu, Z.-L. *Powder Technology* **2005**, *154*, 70–72.
- [166] Birnie, D. P.; Bendzko, N. J. *Materials Chemistry and Physics* **1999**, *59*, 26–35.
Sui, R.; Thangadurai, V.; Berlinguette, C. P. *Chemistry of Materials* **2008**, *20*, 7022–7030.

ELSEVIER LICENSE
TERMS AND CONDITIONS

Apr 14, 2015

This is a License Agreement between Victoria Davis ("You") and Elsevier ("Elsevier") provided by Copyright Clearance Center ("CCC"). The license consists of your order details, the terms and conditions provided by Elsevier, and the payment terms and conditions.

All payments must be made in full to CCC. For payment instructions, please see information listed at the bottom of this form.

Supplier	Elsevier Limited The Boulevard, Langford Lane Kidlington, Oxford, OX5 1GB, UK
Registered Company Number	1982084
Customer name	Victoria Davis
Customer address	2000 Simcoe Street North Oshawa, ON L1H 7K4
License number	3607400444973
License date	Apr 13, 2015
Licensed content publisher	Elsevier
Licensed content publication	Coordination Chemistry Reviews
Licensed content title	Significant influence of TiO ₂ photoelectrode morphology on the energy conversion efficiency of N719 dye-sensitized solar cell
Licensed content author	Zhong-Sheng Wang, Hiroshi Kawauchi, Takeo Kashima, Hironori Arakawa
Licensed content date	July 2004
Licensed content volume number	248
Licensed content issue number	13-14
Number of pages	9
Start Page	1381
End Page	1389
Type of Use	reuse in a thesis/dissertation
Portion	figures/tables/illustrations
Number of figures/tables/illustrations	1
Format	both print and electronic
Are you the author of this Elsevier article?	No

Will you be translating?	No
Order reference number	15
Original figure numbers	Fig 1
Title of your thesis/dissertation	Investigation of Dye-Sensitized Solar Cell Performance with Single Chirality Semiconducting Carbon Nanotubes
Expected completion date	Apr 2015
Estimated size (number of pages)	160
Elsevier VAT number	GB 494 6272 12
Permissions price	0.00 USD
VAT/Local Sales Tax	0.00 USD / 0.00 GBP
Total	0.00 USD
Terms and Conditions	

INTRODUCTION

1. The publisher for this copyrighted material is Elsevier. By clicking "accept" in connection with completing this licensing transaction, you agree that the following terms and conditions apply to this transaction (along with the Billing and Payment terms and conditions established by Copyright Clearance Center, Inc. ("CCC"), at the time that you opened your Rightslink account and that are available at any time at <http://myaccount.copyright.com>).

GENERAL TERMS

2. Elsevier hereby grants you permission to reproduce the aforementioned material subject to the terms and conditions indicated.

3. Acknowledgement: If any part of the material to be used (for example, figures) has appeared in our publication with credit or acknowledgement to another source, permission must also be sought from that source. If such permission is not obtained then that material may not be included in your publication/copies. Suitable acknowledgement to the source must be made, either as a footnote or in a reference list at the end of your publication, as follows:

"Reprinted from Publication title, Vol /edition number, Author(s), Title of article / title of chapter, Pages No., Copyright (Year), with permission from Elsevier [OR APPLICABLE SOCIETY COPYRIGHT OWNER]." Also Lancet special credit - "Reprinted from The Lancet, Vol. number, Author(s), Title of article, Pages No., Copyright (Year), with permission from Elsevier."

4. Reproduction of this material is confined to the purpose and/or media for which permission is hereby given.

5. Altering/Modifying Material: Not Permitted. However figures and illustrations may be

altered/adapted minimally to serve your work. Any other abbreviations, additions, deletions and/or any other alterations shall be made only with prior written authorization of Elsevier Ltd. (Please contact Elsevier at permissions@elsevier.com)

6. If the permission fee for the requested use of our material is waived in this instance, please be advised that your future requests for Elsevier materials may attract a fee.

7. **Reservation of Rights:** Publisher reserves all rights not specifically granted in the combination of (i) the license details provided by you and accepted in the course of this licensing transaction, (ii) these terms and conditions and (iii) CCC's Billing and Payment terms and conditions.

8. **License Contingent Upon Payment:** While you may exercise the rights licensed immediately upon issuance of the license at the end of the licensing process for the transaction, provided that you have disclosed complete and accurate details of your proposed use, no license is finally effective unless and until full payment is received from you (either by publisher or by CCC) as provided in CCC's Billing and Payment terms and conditions. If full payment is not received on a timely basis, then any license preliminarily granted shall be deemed automatically revoked and shall be void as if never granted. Further, in the event that you breach any of these terms and conditions or any of CCC's Billing and Payment terms and conditions, the license is automatically revoked and shall be void as if never granted. Use of materials as described in a revoked license, as well as any use of the materials beyond the scope of an unrevoked license, may constitute copyright infringement and publisher reserves the right to take any and all action to protect its copyright in the materials.

9. **Warranties:** Publisher makes no representations or warranties with respect to the licensed material.

10. **Indemnity:** You hereby indemnify and agree to hold harmless publisher and CCC, and their respective officers, directors, employees and agents, from and against any and all claims arising out of your use of the licensed material other than as specifically authorized pursuant to this license.

11. **No Transfer of License:** This license is personal to you and may not be sublicensed, assigned, or transferred by you to any other person without publisher's written permission.

12. **No Amendment Except in Writing:** This license may not be amended except in a writing signed by both parties (or, in the case of publisher, by CCC on publisher's behalf).

13. **Objection to Contrary Terms:** Publisher hereby objects to any terms contained in any purchase order, acknowledgment, check endorsement or other writing prepared by you, which terms are inconsistent with these terms and conditions or CCC's Billing and Payment terms and conditions. These terms and conditions, together with CCC's Billing and Payment terms and conditions (which are incorporated herein), comprise the entire agreement between you and publisher (and CCC) concerning this licensing transaction. In

the event of any conflict between your obligations established by these terms and conditions and those established by CCC's Billing and Payment terms and conditions, these terms and conditions shall control.

14. **Revocation:** Elsevier or Copyright Clearance Center may deny the permissions described in this License at their sole discretion, for any reason or no reason, with a full refund payable to you. Notice of such denial will be made using the contact information provided by you. Failure to receive such notice will not alter or invalidate the denial. In no event will Elsevier or Copyright Clearance Center be responsible or liable for any costs, expenses or damage incurred by you as a result of a denial of your permission request, other than a refund of the amount(s) paid by you to Elsevier and/or Copyright Clearance Center for denied permissions.

LIMITED LICENSE

The following terms and conditions apply only to specific license types:

15. **Translation:** This permission is granted for non-exclusive world **English** rights only unless your license was granted for translation rights. If you licensed translation rights you may only translate this content into the languages you requested. A professional translator must perform all translations and reproduce the content word for word preserving the integrity of the article. If this license is to re-use 1 or 2 figures then permission is granted for non-exclusive world rights in all languages.

16. **Posting licensed content on any Website:** The following terms and conditions apply as follows: Licensing material from an Elsevier journal: All content posted to the web site must maintain the copyright information line on the bottom of each image; A hyper-text must be included to the Homepage of the journal from which you are licensing at <http://www.sciencedirect.com/science/journal/xxxxx> or the Elsevier homepage for books at <http://www.elsevier.com>; Central Storage: This license does not include permission for a scanned version of the material to be stored in a central repository such as that provided by Heron/XanEdu.

Licensing material from an Elsevier book: A hyper-text link must be included to the Elsevier homepage at <http://www.elsevier.com> . All content posted to the web site must maintain the copyright information line on the bottom of each image.

Posting licensed content on Electronic reserve: In addition to the above the following clauses are applicable: The web site must be password-protected and made available only to bona fide students registered on a relevant course. This permission is granted for 1 year only. You may obtain a new license for future website posting.

17. **For journal authors:** the following clauses are applicable in addition to the above:

Preprints:

A preprint is an author's own write-up of research results and analysis, it has not been peer-reviewed, nor has it had any other value added to it by a publisher (such as formatting, copyright, technical enhancement etc.).

Authors can share their preprints anywhere at any time. Preprints should not be added to or enhanced in any way in order to appear more like, or to substitute for, the final versions of articles however authors can update their preprints on arXiv or RePEc with their Accepted Author Manuscript (see below).

If accepted for publication, we encourage authors to link from the preprint to their formal publication via its DOI. Millions of researchers have access to the formal publications on ScienceDirect, and so links will help users to find, access, cite and use the best available version. Please note that Cell Press, The Lancet and some society-owned have different preprint policies. Information on these policies is available on the journal homepage.

Accepted Author Manuscripts: An accepted author manuscript is the manuscript of an article that has been accepted for publication and which typically includes author-incorporated changes suggested during submission, peer review and editor-author communications.

Authors can share their accepted author manuscript:

- – immediately
 - via their non-commercial person homepage or blog
 - by updating a preprint in arXiv or RePEc with the accepted manuscript
 - via their research institute or institutional repository for internal institutional uses or as part of an invitation-only research collaboration work-group
 - directly by providing copies to their students or to research collaborators for their personal use
 - for private scholarly sharing as part of an invitation-only work group on commercial sites with which Elsevier has an agreement
- – after the embargo period
 - via non-commercial hosting platforms such as their institutional repository
 - via commercial sites with which Elsevier has an agreement

In all cases accepted manuscripts should:

- – link to the formal publication via its DOI
- – bear a CC-BY-NC-ND license - this is easy to do
- – if aggregated with other manuscripts, for example in a repository or other site, be shared in alignment with our hosting policy not be added to or enhanced in any

way to appear more like, or to substitute for, the published journal article.

Published journal article (JPA): A published journal article (PJA) is the definitive final record of published research that appears or will appear in the journal and embodies all value-adding publishing activities including peer review co-ordination, copy-editing, formatting, (if relevant) pagination and online enrichment.

Policies for sharing publishing journal articles differ for subscription and gold open access articles:

Subscription Articles: If you are an author, please share a link to your article rather than the full-text. Millions of researchers have access to the formal publications on ScienceDirect, and so links will help your users to find, access, cite, and use the best available version.

Theses and dissertations which contain embedded PJAs as part of the formal submission can be posted publicly by the awarding institution with DOI links back to the formal publications on ScienceDirect.

If you are affiliated with a library that subscribes to ScienceDirect you have additional private sharing rights for others' research accessed under that agreement. This includes use for classroom teaching and internal training at the institution (including use in course packs and courseware programs), and inclusion of the article for grant funding purposes.

Gold Open Access Articles: May be shared according to the author-selected end-user license and should contain a [CrossMark logo](#), the end user license, and a DOI link to the formal publication on ScienceDirect.

Please refer to Elsevier's [posting policy](#) for further information.

18. **For book authors** the following clauses are applicable in addition to the above: Authors are permitted to place a brief summary of their work online only. You are not allowed to download and post the published electronic version of your chapter, nor may you scan the printed edition to create an electronic version. **Posting to a repository:** Authors are permitted to post a summary of their chapter only in their institution's repository.

19. **Thesis/Dissertation:** If your license is for use in a thesis/dissertation your thesis may be submitted to your institution in either print or electronic form. Should your thesis be published commercially, please reapply for permission. These requirements include permission for the Library and Archives of Canada to supply single copies, on demand, of the complete thesis and include permission for Proquest/UMI to supply single copies, on demand, of the complete thesis. Should your thesis be published commercially, please reapply for permission. Theses and dissertations which contain embedded PJAs as part of the formal submission can be posted publicly by the awarding institution with DOI links

back to the formal publications on ScienceDirect.

Elsevier Open Access Terms and Conditions

You can publish open access with Elsevier in hundreds of open access journals or in nearly 2000 established subscription journals that support open access publishing. Permitted third party re-use of these open access articles is defined by the author's choice of Creative Commons user license. See our [open access license policy](#) for more information.

Terms & Conditions applicable to all Open Access articles published with Elsevier:

Any reuse of the article must not represent the author as endorsing the adaptation of the article nor should the article be modified in such a way as to damage the author's honour or reputation. If any changes have been made, such changes must be clearly indicated.

The author(s) must be appropriately credited and we ask that you include the end user license and a DOI link to the formal publication on ScienceDirect.

If any part of the material to be used (for example, figures) has appeared in our publication with credit or acknowledgement to another source it is the responsibility of the user to ensure their reuse complies with the terms and conditions determined by the rights holder.

Additional Terms & Conditions applicable to each Creative Commons user license:

CC BY: The CC-BY license allows users to copy, to create extracts, abstracts and new works from the Article, to alter and revise the Article and to make commercial use of the Article (including reuse and/or resale of the Article by commercial entities), provided the user gives appropriate credit (with a link to the formal publication through the relevant DOI), provides a link to the license, indicates if changes were made and the licensor is not represented as endorsing the use made of the work. The full details of the license are available at <http://creativecommons.org/licenses/by/4.0>.

CC BY NC SA: The CC BY-NC-SA license allows users to copy, to create extracts, abstracts and new works from the Article, to alter and revise the Article, provided this is not done for commercial purposes, and that the user gives appropriate credit (with a link to the formal publication through the relevant DOI), provides a link to the license, indicates if changes were made and the licensor is not represented as endorsing the use made of the work. Further, any new works must be made available on the same conditions. The full details of the license are available at <http://creativecommons.org/licenses/by-nc-sa/4.0>.

CC BY NC ND: The CC BY-NC-ND license allows users to copy and distribute the Article, provided this is not done for commercial purposes and further does not permit distribution of the Article if it is changed or edited in any way, and provided the user gives appropriate credit (with a link to the formal publication through the relevant DOI),

provides a link to the license, and that the licensor is not represented as endorsing the use made of the work. The full details of the license are available at <http://creativecommons.org/licenses/by-nc-nd/4.0>. Any commercial reuse of Open Access articles published with a CC BY NC SA or CC BY NC ND license requires permission from Elsevier and will be subject to a fee.

Commercial reuse includes:

- – Associating advertising with the full text of the Article
- – Charging fees for document delivery or access
- – Article aggregation
- – Systematic distribution via e-mail lists or share buttons

Posting or linking by commercial companies for use by customers of those companies.

20. Other Conditions:

Questions? customercare@copyright.com or +1-855-239-3415 (toll free in the US) or +1-978-646-2777.

Gratis licenses (referencing \$0 in the Total field) are free. Please retain this printable license for your reference. No payment is required.

ELSEVIER LICENSE
TERMS AND CONDITIONS

Apr 14, 2015

This is a License Agreement between Victoria Davis ("You") and Elsevier ("Elsevier") provided by Copyright Clearance Center ("CCC"). The license consists of your order details, the terms and conditions provided by Elsevier, and the payment terms and conditions.

All payments must be made in full to CCC. For payment instructions, please see information listed at the bottom of this form.

Supplier	Elsevier Limited The Boulevard, Langford Lane Kidlington, Oxford, OX5 1GB, UK
Registered Company Number	1982084
Customer name	Victoria Davis
Customer address	2000 Simcoe Street North Oshawa, ON L1H 7K4
License number	3607400642919
License date	Apr 13, 2015
Licensed content publisher	Elsevier
Licensed content publication	Coordination Chemistry Reviews
Licensed content title	Significant influence of TiO ₂ photoelectrode morphology on the energy conversion efficiency of N719 dye-sensitized solar cell
Licensed content author	Zhong-Sheng Wang, Hiroshi Kawauchi, Takeo Kashima, Hironori Arakawa
Licensed content date	July 2004
Licensed content volume number	248
Licensed content issue number	13-14
Number of pages	9
Start Page	1381
End Page	1389
Type of Use	reuse in a thesis/dissertation
Intended publisher of new work	other
Portion	figures/tables/illustrations
Number of figures/tables/illustrations	1
Format	both print and electronic
Are you the author of this Elsevier No	

article?	
Will you be translating?	No
Order reference number	19
Original figure numbers	Fig 1
Title of your thesis/dissertation	Investigation of Dye-Sensitized Solar Cell Performance with Single Chirality Semiconducting Carbon Nanotubes
Expected completion date	Apr 2015
Estimated size (number of pages)	160
Elsevier VAT number	GB 494 6272 12
Permissions price	0.00 USD
VAT/Local Sales Tax	0.00 USD / 0.00 GBP
Total	0.00 USD
Terms and Conditions	

INTRODUCTION

1. The publisher for this copyrighted material is Elsevier. By clicking "accept" in connection with completing this licensing transaction, you agree that the following terms and conditions apply to this transaction (along with the Billing and Payment terms and conditions established by Copyright Clearance Center, Inc. ("CCC"), at the time that you opened your Rightslink account and that are available at any time at <http://myaccount.copyright.com>).

GENERAL TERMS

2. Elsevier hereby grants you permission to reproduce the aforementioned material subject to the terms and conditions indicated.

3. Acknowledgement: If any part of the material to be used (for example, figures) has appeared in our publication with credit or acknowledgement to another source, permission must also be sought from that source. If such permission is not obtained then that material may not be included in your publication/copies. Suitable acknowledgement to the source must be made, either as a footnote or in a reference list at the end of your publication, as follows:

"Reprinted from Publication title, Vol /edition number, Author(s), Title of article / title of chapter, Pages No., Copyright (Year), with permission from Elsevier [OR APPLICABLE SOCIETY COPYRIGHT OWNER]." Also Lancet special credit - "Reprinted from The Lancet, Vol. number, Author(s), Title of article, Pages No., Copyright (Year), with permission from Elsevier."

4. Reproduction of this material is confined to the purpose and/or media for which permission is hereby given.

5. **Altering/Modifying Material: Not Permitted.** However figures and illustrations may be altered/adapted minimally to serve your work. Any other abbreviations, additions, deletions and/or any other alterations shall be made only with prior written authorization of Elsevier Ltd. (Please contact Elsevier at permissions@elsevier.com)

6. If the permission fee for the requested use of our material is waived in this instance, please be advised that your future requests for Elsevier materials may attract a fee.

7. **Reservation of Rights:** Publisher reserves all rights not specifically granted in the combination of (i) the license details provided by you and accepted in the course of this licensing transaction, (ii) these terms and conditions and (iii) CCC's Billing and Payment terms and conditions.

8. **License Contingent Upon Payment:** While you may exercise the rights licensed immediately upon issuance of the license at the end of the licensing process for the transaction, provided that you have disclosed complete and accurate details of your proposed use, no license is finally effective unless and until full payment is received from you (either by publisher or by CCC) as provided in CCC's Billing and Payment terms and conditions. If full payment is not received on a timely basis, then any license preliminarily granted shall be deemed automatically revoked and shall be void as if never granted. Further, in the event that you breach any of these terms and conditions or any of CCC's Billing and Payment terms and conditions, the license is automatically revoked and shall be void as if never granted. Use of materials as described in a revoked license, as well as any use of the materials beyond the scope of an unrevoked license, may constitute copyright infringement and publisher reserves the right to take any and all action to protect its copyright in the materials.

9. **Warranties:** Publisher makes no representations or warranties with respect to the licensed material.

10. **Indemnity:** You hereby indemnify and agree to hold harmless publisher and CCC, and their respective officers, directors, employees and agents, from and against any and all claims arising out of your use of the licensed material other than as specifically authorized pursuant to this license.

11. **No Transfer of License:** This license is personal to you and may not be sublicensed, assigned, or transferred by you to any other person without publisher's written permission.

12. **No Amendment Except in Writing:** This license may not be amended except in a writing signed by both parties (or, in the case of publisher, by CCC on publisher's behalf).

13. **Objection to Contrary Terms:** Publisher hereby objects to any terms contained in any purchase order, acknowledgment, check endorsement or other writing prepared by you, which terms are inconsistent with these terms and conditions or CCC's Billing and Payment terms and conditions. These terms and conditions, together with CCC's Billing and Payment terms and conditions (which are incorporated herein), comprise the entire

agreement between you and publisher (and CCC) concerning this licensing transaction. In the event of any conflict between your obligations established by these terms and conditions and those established by CCC's Billing and Payment terms and conditions, these terms and conditions shall control.

14. **Revocation:** Elsevier or Copyright Clearance Center may deny the permissions described in this License at their sole discretion, for any reason or no reason, with a full refund payable to you. Notice of such denial will be made using the contact information provided by you. Failure to receive such notice will not alter or invalidate the denial. In no event will Elsevier or Copyright Clearance Center be responsible or liable for any costs, expenses or damage incurred by you as a result of a denial of your permission request, other than a refund of the amount(s) paid by you to Elsevier and/or Copyright Clearance Center for denied permissions.

LIMITED LICENSE

The following terms and conditions apply only to specific license types:

15. **Translation:** This permission is granted for non-exclusive world **English** rights only unless your license was granted for translation rights. If you licensed translation rights you may only translate this content into the languages you requested. A professional translator must perform all translations and reproduce the content word for word preserving the integrity of the article. If this license is to re-use 1 or 2 figures then permission is granted for non-exclusive world rights in all languages.

16. **Posting licensed content on any Website:** The following terms and conditions apply as follows: Licensing material from an Elsevier journal: All content posted to the web site must maintain the copyright information line on the bottom of each image; A hyper-text must be included to the Homepage of the journal from which you are licensing at <http://www.sciencedirect.com/science/journal/xxxxx> or the Elsevier homepage for books at <http://www.elsevier.com>; Central Storage: This license does not include permission for a scanned version of the material to be stored in a central repository such as that provided by Heron/XanEdu.

Licensing material from an Elsevier book: A hyper-text link must be included to the Elsevier homepage at <http://www.elsevier.com>. All content posted to the web site must maintain the copyright information line on the bottom of each image.

Posting licensed content on Electronic reserve: In addition to the above the following clauses are applicable: The web site must be password-protected and made available only to bona fide students registered on a relevant course. This permission is granted for 1 year only. You may obtain a new license for future website posting.

17. **For journal authors:** the following clauses are applicable in addition to the above:

Preprints:

A preprint is an author's own write-up of research results and analysis, it has not been peer-reviewed, nor has it had any other value added to it by a publisher (such as formatting, copyright, technical enhancement etc.).

Authors can share their preprints anywhere at any time. Preprints should not be added to or enhanced in any way in order to appear more like, or to substitute for, the final versions of articles however authors can update their preprints on arXiv or RePEc with their Accepted Author Manuscript (see below).

If accepted for publication, we encourage authors to link from the preprint to their formal publication via its DOI. Millions of researchers have access to the formal publications on ScienceDirect, and so links will help users to find, access, cite and use the best available version. Please note that Cell Press, The Lancet and some society-owned have different preprint policies. Information on these policies is available on the journal homepage.

Accepted Author Manuscripts: An accepted author manuscript is the manuscript of an article that has been accepted for publication and which typically includes author-incorporated changes suggested during submission, peer review and editor-author communications.

Authors can share their accepted author manuscript:

- – immediately
 - via their non-commercial person homepage or blog
 - by updating a preprint in arXiv or RePEc with the accepted manuscript
 - via their research institute or institutional repository for internal institutional uses or as part of an invitation-only research collaboration work-group
 - directly by providing copies to their students or to research collaborators for their personal use
 - for private scholarly sharing as part of an invitation-only work group on commercial sites with which Elsevier has an agreement
- – after the embargo period
 - via non-commercial hosting platforms such as their institutional repository
 - via commercial sites with which Elsevier has an agreement

In all cases accepted manuscripts should:

- – link to the formal publication via its DOI
- – bear a CC-BY-NC-ND license - this is easy to do
- – if aggregated with other manuscripts, for example in a repository or other site, be shared in alignment with our hosting policy not be added to or enhanced in any

way to appear more like, or to substitute for, the published journal article.

Published journal article (JPA): A published journal article (PJA) is the definitive final record of published research that appears or will appear in the journal and embodies all value-adding publishing activities including peer review co-ordination, copy-editing, formatting, (if relevant) pagination and online enrichment.

Policies for sharing publishing journal articles differ for subscription and gold open access articles:

Subscription Articles: If you are an author, please share a link to your article rather than the full-text. Millions of researchers have access to the formal publications on ScienceDirect, and so links will help your users to find, access, cite, and use the best available version.

Theses and dissertations which contain embedded PJAs as part of the formal submission can be posted publicly by the awarding institution with DOI links back to the formal publications on ScienceDirect.

If you are affiliated with a library that subscribes to ScienceDirect you have additional private sharing rights for others' research accessed under that agreement. This includes use for classroom teaching and internal training at the institution (including use in course packs and courseware programs), and inclusion of the article for grant funding purposes.

Gold Open Access Articles: May be shared according to the author-selected end-user license and should contain a [CrossMark logo](#), the end user license, and a DOI link to the formal publication on ScienceDirect.

Please refer to Elsevier's [posting policy](#) for further information.

18. **For book authors** the following clauses are applicable in addition to the above: Authors are permitted to place a brief summary of their work online only. You are not allowed to download and post the published electronic version of your chapter, nor may you scan the printed edition to create an electronic version. **Posting to a repository:** Authors are permitted to post a summary of their chapter only in their institution's repository.

19. **Thesis/Dissertation:** If your license is for use in a thesis/dissertation your thesis may be submitted to your institution in either print or electronic form. Should your thesis be published commercially, please reapply for permission. These requirements include permission for the Library and Archives of Canada to supply single copies, on demand, of the complete thesis and include permission for Proquest/UMI to supply single copies, on demand, of the complete thesis. Should your thesis be published commercially, please reapply for permission. Theses and dissertations which contain embedded PJAs as part of the formal submission can be posted publicly by the awarding institution with DOI links

back to the formal publications on ScienceDirect.

Elsevier Open Access Terms and Conditions

You can publish open access with Elsevier in hundreds of open access journals or in nearly 2000 established subscription journals that support open access publishing. Permitted third party re-use of these open access articles is defined by the author's choice of Creative Commons user license. See our [open access license policy](#) for more information.

Terms & Conditions applicable to all Open Access articles published with Elsevier:

Any reuse of the article must not represent the author as endorsing the adaptation of the article nor should the article be modified in such a way as to damage the author's honour or reputation. If any changes have been made, such changes must be clearly indicated.

The author(s) must be appropriately credited and we ask that you include the end user license and a DOI link to the formal publication on ScienceDirect.

If any part of the material to be used (for example, figures) has appeared in our publication with credit or acknowledgement to another source it is the responsibility of the user to ensure their reuse complies with the terms and conditions determined by the rights holder.

Additional Terms & Conditions applicable to each Creative Commons user license:

CC BY: The CC-BY license allows users to copy, to create extracts, abstracts and new works from the Article, to alter and revise the Article and to make commercial use of the Article (including reuse and/or resale of the Article by commercial entities), provided the user gives appropriate credit (with a link to the formal publication through the relevant DOI), provides a link to the license, indicates if changes were made and the licensor is not represented as endorsing the use made of the work. The full details of the license are available at <http://creativecommons.org/licenses/by/4.0>.

CC BY NC SA: The CC BY-NC-SA license allows users to copy, to create extracts, abstracts and new works from the Article, to alter and revise the Article, provided this is not done for commercial purposes, and that the user gives appropriate credit (with a link to the formal publication through the relevant DOI), provides a link to the license, indicates if changes were made and the licensor is not represented as endorsing the use made of the work. Further, any new works must be made available on the same conditions. The full details of the license are available at <http://creativecommons.org/licenses/by-nc-sa/4.0>.

CC BY NC ND: The CC BY-NC-ND license allows users to copy and distribute the Article, provided this is not done for commercial purposes and further does not permit distribution of the Article if it is changed or edited in any way, and provided the user gives appropriate credit (with a link to the formal publication through the relevant DOI),

provides a link to the license, and that the licensor is not represented as endorsing the use made of the work. The full details of the license are available at <http://creativecommons.org/licenses/by-nc-nd/4.0>. Any commercial reuse of Open Access articles published with a CC BY NC SA or CC BY NC ND license requires permission from Elsevier and will be subject to a fee.

Commercial reuse includes:

- – Associating advertising with the full text of the Article
- – Charging fees for document delivery or access
- – Article aggregation
- – Systematic distribution via e-mail lists or share buttons

Posting or linking by commercial companies for use by customers of those companies.

20. Other Conditions:

Questions? customercare@copyright.com or +1-855-239-3415 (toll free in the US) or +1-978-646-2777.

Gratis licenses (referencing \$0 in the Total field) are free. Please retain this printable license for your reference. No payment is required.

NATURE PUBLISHING GROUP LICENSE
TERMS AND CONDITIONS

Apr 14, 2015

This is a License Agreement between Victoria Davis ("You") and Nature Publishing Group ("Nature Publishing Group") provided by Copyright Clearance Center ("CCC"). The license consists of your order details, the terms and conditions provided by Nature Publishing Group, and the payment terms and conditions.

All payments must be made in full to CCC. For payment instructions, please see information listed at the bottom of this form.

License Number	3607401106394
License date	Apr 13, 2015
Licensed content publisher	Nature Publishing Group
Licensed content publication	Nature Photonics
Licensed content title	The renaissance of dye-sensitized solar cells
Licensed content author	Brian E. Hardin, Henry J. Snaith, Michael D. McGehee
Licensed content date	Feb 29, 2012
Volume number	6
Issue number	3
Type of Use	reuse in a dissertation / thesis
Requestor type	academic/educational
Format	print and electronic
Portion	figures/tables/illustrations
Number of figures/tables/illustrations	1
High-res required	no
Figures	Figure 1
Author of this NPG article	no
Your reference number	15
Title of your thesis / dissertation	Investigation of Dye-Sensitized Solar Cell Performance with Single Chirality Semiconducting Carbon Nanotubes
Expected completion date	Apr 2015
Estimated size (number of pages)	160
Total	0.00 USD
Terms and Conditions	

Terms and Conditions for Permissions

Nature Publishing Group hereby grants you a non-exclusive license to reproduce this material for this purpose, and for no other use, subject to the conditions below:

1. NPG warrants that it has, to the best of its knowledge, the rights to license reuse of this material. However, you should ensure that the material you are requesting is original to Nature Publishing Group and does not carry the copyright of another entity (as credited in the published version). If the credit line on any part of the material you have requested indicates that it was reprinted or adapted by NPG with permission from another source, then you should also seek permission from that source to reuse the material.
2. Permission granted free of charge for material in print is also usually granted for any electronic version of that work, provided that the material is incidental to the work as a whole and that the electronic version is essentially equivalent to, or substitutes for, the print version. Where print permission has been granted for a fee, separate permission must be obtained for any additional, electronic re-use (unless, as in the case of a full paper, this has already been accounted for during your initial request in the calculation of a print run). NB: In all cases, web-based use of full-text articles must be authorized separately through the 'Use on a Web Site' option when requesting permission.
3. Permission granted for a first edition does not apply to second and subsequent editions and for editions in other languages (except for signatories to the STM Permissions Guidelines, or where the first edition permission was granted for free).
4. Nature Publishing Group's permission must be acknowledged next to the figure, table or abstract in print. In electronic form, this acknowledgement must be visible at the same time as the figure/table/abstract, and must be hyperlinked to the journal's homepage.
5. The credit line should read:
Reprinted by permission from Macmillan Publishers Ltd: [JOURNAL NAME] (reference citation), copyright (year of publication)
For AOP papers, the credit line should read:
Reprinted by permission from Macmillan Publishers Ltd: [JOURNAL NAME], advance online publication, day month year (doi: 10.1038/sj.[JOURNAL ACRONYM].XXXXX)

Note: For republication from the *British Journal of Cancer*, the following credit lines apply.

Reprinted by permission from Macmillan Publishers Ltd on behalf of Cancer Research UK: [JOURNAL NAME] (reference citation), copyright (year of publication) For AOP papers, the credit line should read:
Reprinted by permission from Macmillan Publishers Ltd on behalf of Cancer

Research UK: [JOURNAL NAME], advance online publication, day month year
(doi: 10.1038/sj.[JOURNAL ACRONYM].XXXXX)

6. Adaptations of single figures do not require NPG approval. However, the adaptation should be credited as follows:

Adapted by permission from Macmillan Publishers Ltd: [JOURNAL NAME]
(reference citation), copyright (year of publication)

Note: For adaptation from the *British Journal of Cancer*, the following credit line applies.

Adapted by permission from Macmillan Publishers Ltd on behalf of Cancer Research UK: [JOURNAL NAME] (reference citation), copyright (year of publication)

7. Translations of 401 words up to a whole article require NPG approval. Please visit <http://www.macmillanmedicalcommunications.com> for more information. Translations of up to a 400 words do not require NPG approval. The translation should be credited as follows:

Translated by permission from Macmillan Publishers Ltd: [JOURNAL NAME]
(reference citation), copyright (year of publication).

Note: For translation from the *British Journal of Cancer*, the following credit line applies.

Translated by permission from Macmillan Publishers Ltd on behalf of Cancer Research UK: [JOURNAL NAME] (reference citation), copyright (year of publication)

We are certain that all parties will benefit from this agreement and wish you the best in the use of this material. Thank you.

Special Terms:

v1.1

Questions? customercare@copyright.com or +1-855-239-3415 (toll free in the US) or +1-978-646-2777.

Gratis licenses (referencing \$0 in the Total field) are free. Please retain this printable license for your reference. No payment is required.

ELSEVIER LICENSE
TERMS AND CONDITIONS

Apr 14, 2015

This is a License Agreement between Victoria Davis ("You") and Elsevier ("Elsevier") provided by Copyright Clearance Center ("CCC"). The license consists of your order details, the terms and conditions provided by Elsevier, and the payment terms and conditions.

All payments must be made in full to CCC. For payment instructions, please see information listed at the bottom of this form.

Supplier	Elsevier Limited The Boulevard, Langford Lane Kidlington, Oxford, OX5 1GB, UK
Registered Company Number	1982084
Customer name	Victoria Davis
Customer address	2000 Simcoe Street North Oshawa, ON L1H 7K4
License number	3607401288860
License date	Apr 13, 2015
Licensed content publisher	Elsevier
Licensed content publication	Progress in Solid State Chemistry
Licensed content title	Photoinduced reactivity of titanium dioxide
Licensed content author	O. Carp, C.L. Huisman, A. Reller
Licensed content date	2004
Licensed content volume number	32
Licensed content issue number	1-2
Number of pages	145
Start Page	33
End Page	177
Type of Use	reuse in a thesis/dissertation
Intended publisher of new work	other
Portion	figures/tables/illustrations
Number of figures/tables/illustrations	1
Format	both print and electronic
Are you the author of this Elsevier article?	No
Will you be translating?	No
Order reference number	20
Original figure numbers	Figure 3

Title of your thesis/dissertation	Investigation of Dye-Sensitized Solar Cell Performance with Single Chirality Semiconducting Carbon Nanotubes
Expected completion date	Apr 2015
Estimated size (number of pages)	160
Elsevier VAT number	GB 494 6272 12
Permissions price	0.00 USD
VAT/Local Sales Tax	0.00 USD / 0.00 GBP
Total	0.00 USD
Terms and Conditions	

INTRODUCTION

1. The publisher for this copyrighted material is Elsevier. By clicking "accept" in connection with completing this licensing transaction, you agree that the following terms and conditions apply to this transaction (along with the Billing and Payment terms and conditions established by Copyright Clearance Center, Inc. ("CCC"), at the time that you opened your Rightslink account and that are available at any time at <http://myaccount.copyright.com>).

GENERAL TERMS

2. Elsevier hereby grants you permission to reproduce the aforementioned material subject to the terms and conditions indicated.

3. Acknowledgement: If any part of the material to be used (for example, figures) has appeared in our publication with credit or acknowledgement to another source, permission must also be sought from that source. If such permission is not obtained then that material may not be included in your publication/copies. Suitable acknowledgement to the source must be made, either as a footnote or in a reference list at the end of your publication, as follows:

"Reprinted from Publication title, Vol /edition number, Author(s), Title of article / title of chapter, Pages No., Copyright (Year), with permission from Elsevier [OR APPLICABLE SOCIETY COPYRIGHT OWNER]." Also Lancet special credit - "Reprinted from The Lancet, Vol. number, Author(s), Title of article, Pages No., Copyright (Year), with permission from Elsevier."

4. Reproduction of this material is confined to the purpose and/or media for which permission is hereby given.

5. Altering/Modifying Material: Not Permitted. However figures and illustrations may be altered/adapted minimally to serve your work. Any other abbreviations, additions, deletions and/or any other alterations shall be made only with prior written authorization of Elsevier

Ltd. (Please contact Elsevier at permissions@elsevier.com)

6. If the permission fee for the requested use of our material is waived in this instance, please be advised that your future requests for Elsevier materials may attract a fee.

7. **Reservation of Rights:** Publisher reserves all rights not specifically granted in the combination of (i) the license details provided by you and accepted in the course of this licensing transaction, (ii) these terms and conditions and (iii) CCC's Billing and Payment terms and conditions.

8. **License Contingent Upon Payment:** While you may exercise the rights licensed immediately upon issuance of the license at the end of the licensing process for the transaction, provided that you have disclosed complete and accurate details of your proposed use, no license is finally effective unless and until full payment is received from you (either by publisher or by CCC) as provided in CCC's Billing and Payment terms and conditions. If full payment is not received on a timely basis, then any license preliminarily granted shall be deemed automatically revoked and shall be void as if never granted. Further, in the event that you breach any of these terms and conditions or any of CCC's Billing and Payment terms and conditions, the license is automatically revoked and shall be void as if never granted. Use of materials as described in a revoked license, as well as any use of the materials beyond the scope of an unrevoked license, may constitute copyright infringement and publisher reserves the right to take any and all action to protect its copyright in the materials.

9. **Warranties:** Publisher makes no representations or warranties with respect to the licensed material.

10. **Indemnity:** You hereby indemnify and agree to hold harmless publisher and CCC, and their respective officers, directors, employees and agents, from and against any and all claims arising out of your use of the licensed material other than as specifically authorized pursuant to this license.

11. **No Transfer of License:** This license is personal to you and may not be sublicensed, assigned, or transferred by you to any other person without publisher's written permission.

12. **No Amendment Except in Writing:** This license may not be amended except in a writing signed by both parties (or, in the case of publisher, by CCC on publisher's behalf).

13. **Objection to Contrary Terms:** Publisher hereby objects to any terms contained in any purchase order, acknowledgment, check endorsement or other writing prepared by you, which terms are inconsistent with these terms and conditions or CCC's Billing and Payment terms and conditions. These terms and conditions, together with CCC's Billing and Payment terms and conditions (which are incorporated herein), comprise the entire agreement between you and publisher (and CCC) concerning this licensing transaction. In the event of any conflict between your obligations established by these terms and conditions and those established by CCC's Billing and Payment terms and conditions, these

terms and conditions shall control.

14. **Revocation:** Elsevier or Copyright Clearance Center may deny the permissions described in this License at their sole discretion, for any reason or no reason, with a full refund payable to you. Notice of such denial will be made using the contact information provided by you. Failure to receive such notice will not alter or invalidate the denial. In no event will Elsevier or Copyright Clearance Center be responsible or liable for any costs, expenses or damage incurred by you as a result of a denial of your permission request, other than a refund of the amount(s) paid by you to Elsevier and/or Copyright Clearance Center for denied permissions.

LIMITED LICENSE

The following terms and conditions apply only to specific license types:

15. **Translation:** This permission is granted for non-exclusive world **English** rights only unless your license was granted for translation rights. If you licensed translation rights you may only translate this content into the languages you requested. A professional translator must perform all translations and reproduce the content word for word preserving the integrity of the article. If this license is to re-use 1 or 2 figures then permission is granted for non-exclusive world rights in all languages.

16. **Posting licensed content on any Website:** The following terms and conditions apply as follows: Licensing material from an Elsevier journal: All content posted to the web site must maintain the copyright information line on the bottom of each image; A hyper-text must be included to the Homepage of the journal from which you are licensing at <http://www.sciencedirect.com/science/journal/xxxxx> or the Elsevier homepage for books at <http://www.elsevier.com>; Central Storage: This license does not include permission for a scanned version of the material to be stored in a central repository such as that provided by Heron/XanEdu.

Licensing material from an Elsevier book: A hyper-text link must be included to the Elsevier homepage at <http://www.elsevier.com> . All content posted to the web site must maintain the copyright information line on the bottom of each image.

Posting licensed content on Electronic reserve: In addition to the above the following clauses are applicable: The web site must be password-protected and made available only to bona fide students registered on a relevant course. This permission is granted for 1 year only. You may obtain a new license for future website posting.

17. **For journal authors:** the following clauses are applicable in addition to the above:

Preprints:

A preprint is an author's own write-up of research results and analysis, it has not been peer-

reviewed, nor has it had any other value added to it by a publisher (such as formatting, copyright, technical enhancement etc.).

Authors can share their preprints anywhere at any time. Preprints should not be added to or enhanced in any way in order to appear more like, or to substitute for, the final versions of articles however authors can update their preprints on arXiv or RePEc with their Accepted Author Manuscript (see below).

If accepted for publication, we encourage authors to link from the preprint to their formal publication via its DOI. Millions of researchers have access to the formal publications on ScienceDirect, and so links will help users to find, access, cite and use the best available version. Please note that Cell Press, The Lancet and some society-owned have different preprint policies. Information on these policies is available on the journal homepage.

Accepted Author Manuscripts: An accepted author manuscript is the manuscript of an article that has been accepted for publication and which typically includes author-incorporated changes suggested during submission, peer review and editor-author communications.

Authors can share their accepted author manuscript:

- – immediately
 - via their non-commercial person homepage or blog
 - by updating a preprint in arXiv or RePEc with the accepted manuscript
 - via their research institute or institutional repository for internal institutional uses or as part of an invitation-only research collaboration work-group
 - directly by providing copies to their students or to research collaborators for their personal use
 - for private scholarly sharing as part of an invitation-only work group on commercial sites with which Elsevier has an agreement
- – after the embargo period
 - via non-commercial hosting platforms such as their institutional repository
 - via commercial sites with which Elsevier has an agreement

In all cases accepted manuscripts should:

- – link to the formal publication via its DOI
- – bear a CC-BY-NC-ND license - this is easy to do
- – if aggregated with other manuscripts, for example in a repository or other site, be shared in alignment with our hosting policy not be added to or enhanced in any way to appear more like, or to substitute for, the published journal article.

Published journal article (JPA): A published journal article (PJA) is the definitive final

record of published research that appears or will appear in the journal and embodies all value-adding publishing activities including peer review co-ordination, copy-editing, formatting, (if relevant) pagination and online enrichment.

Policies for sharing publishing journal articles differ for subscription and gold open access articles:

Subscription Articles: If you are an author, please share a link to your article rather than the full-text. Millions of researchers have access to the formal publications on ScienceDirect, and so links will help your users to find, access, cite, and use the best available version.

Theses and dissertations which contain embedded PJAs as part of the formal submission can be posted publicly by the awarding institution with DOI links back to the formal publications on ScienceDirect.

If you are affiliated with a library that subscribes to ScienceDirect you have additional private sharing rights for others' research accessed under that agreement. This includes use for classroom teaching and internal training at the institution (including use in course packs and courseware programs), and inclusion of the article for grant funding purposes.

Gold Open Access Articles: May be shared according to the author-selected end-user license and should contain a [CrossMark logo](#), the end user license, and a DOI link to the formal publication on ScienceDirect.

Please refer to Elsevier's [posting policy](#) for further information.

18. **For book authors** the following clauses are applicable in addition to the above: Authors are permitted to place a brief summary of their work online only. You are not allowed to download and post the published electronic version of your chapter, nor may you scan the printed edition to create an electronic version. **Posting to a repository:** Authors are permitted to post a summary of their chapter only in their institution's repository.

19. **Thesis/Dissertation:** If your license is for use in a thesis/dissertation your thesis may be submitted to your institution in either print or electronic form. Should your thesis be published commercially, please reapply for permission. These requirements include permission for the Library and Archives of Canada to supply single copies, on demand, of the complete thesis and include permission for Proquest/UMI to supply single copies, on demand, of the complete thesis. Should your thesis be published commercially, please reapply for permission. Theses and dissertations which contain embedded PJAs as part of the formal submission can be posted publicly by the awarding institution with DOI links back to the formal publications on ScienceDirect.

Elsevier Open Access Terms and Conditions

You can publish open access with Elsevier in hundreds of open access journals or in nearly 2000 established subscription journals that support open access publishing. Permitted third party re-use of these open access articles is defined by the author's choice of Creative Commons user license. See our [open access license policy](#) for more information.

Terms & Conditions applicable to all Open Access articles published with Elsevier:

Any reuse of the article must not represent the author as endorsing the adaptation of the article nor should the article be modified in such a way as to damage the author's honour or reputation. If any changes have been made, such changes must be clearly indicated.

The author(s) must be appropriately credited and we ask that you include the end user license and a DOI link to the formal publication on ScienceDirect.

If any part of the material to be used (for example, figures) has appeared in our publication with credit or acknowledgement to another source it is the responsibility of the user to ensure their reuse complies with the terms and conditions determined by the rights holder.

Additional Terms & Conditions applicable to each Creative Commons user license:

CC BY: The CC-BY license allows users to copy, to create extracts, abstracts and new works from the Article, to alter and revise the Article and to make commercial use of the Article (including reuse and/or resale of the Article by commercial entities), provided the user gives appropriate credit (with a link to the formal publication through the relevant DOI), provides a link to the license, indicates if changes were made and the licensor is not represented as endorsing the use made of the work. The full details of the license are available at <http://creativecommons.org/licenses/by/4.0>.

CC BY NC SA: The CC BY-NC-SA license allows users to copy, to create extracts, abstracts and new works from the Article, to alter and revise the Article, provided this is not done for commercial purposes, and that the user gives appropriate credit (with a link to the formal publication through the relevant DOI), provides a link to the license, indicates if changes were made and the licensor is not represented as endorsing the use made of the work. Further, any new works must be made available on the same conditions. The full details of the license are available at <http://creativecommons.org/licenses/by-nc-sa/4.0>.

CC BY NC ND: The CC BY-NC-ND license allows users to copy and distribute the Article, provided this is not done for commercial purposes and further does not permit distribution of the Article if it is changed or edited in any way, and provided the user gives appropriate credit (with a link to the formal publication through the relevant DOI), provides a link to the license, and that the licensor is not represented as endorsing the use made of the work. The full details of the license are available at <http://creativecommons.org/licenses/by-nc-nd/4.0>. Any commercial reuse of Open Access articles published with a CC BY NC SA or CC BY NC ND license requires permission

from Elsevier and will be subject to a fee.

Commercial reuse includes:

- – Associating advertising with the full text of the Article
- – Charging fees for document delivery or access
- – Article aggregation
- – Systematic distribution via e-mail lists or share buttons

Posting or linking by commercial companies for use by customers of those companies.

20. Other Conditions:

Questions? customer care@copyright.com or +1-855-239-3415 (toll free in the US) or +1-978-646-2777.

Gratis licenses (referencing \$0 in the Total field) are free. Please retain this printable license for your reference. No payment is required.

ELSEVIER LICENSE
TERMS AND CONDITIONS

Apr 14, 2015

This is a License Agreement between Victoria Davis ("You") and Elsevier ("Elsevier") provided by Copyright Clearance Center ("CCC"). The license consists of your order details, the terms and conditions provided by Elsevier, and the payment terms and conditions.

All payments must be made in full to CCC. For payment instructions, please see information listed at the bottom of this form.

Supplier	Elsevier Limited The Boulevard, Langford Lane Kidlington, Oxford, OX5 1GB, UK
Registered Company Number	1982084
Customer name	Victoria Davis
Customer address	2000 Simcoe Street North Oshawa, ON L1H 7K4
License number	3607401482804
License date	Apr 13, 2015
Licensed content publisher	Elsevier
Licensed content publication	Carbon
Licensed content title	Carbonaceous nanomaterials for the enhancement of TiO ₂ photocatalysis
Licensed content author	Rowan Leary, Aidan Westwood
Licensed content date	March 2011
Licensed content volume number	49
Licensed content issue number	3
Number of pages	32
Start Page	741
End Page	772
Type of Use	reuse in a thesis/dissertation
Intended publisher of new work	other
Portion	figures/tables/illustrations
Number of figures/tables/illustrations	1
Format	both print and electronic
Are you the author of this Elsevier article?	No
Will you be translating?	No

Order reference number	21
Original figure numbers	Figure 9
Title of your thesis/dissertation	Investigation of Dye-Sensitized Solar Cell Performance with Single Chirality Semiconducting Carbon Nanotubes
Expected completion date	Apr 2015
Estimated size (number of pages)	160
Elsevier VAT number	GB 494 6272 12
Permissions price	0.00 USD
VAT/Local Sales Tax	0.00 USD / 0.00 GBP
Total	0.00 USD
Terms and Conditions	

INTRODUCTION

1. The publisher for this copyrighted material is Elsevier. By clicking "accept" in connection with completing this licensing transaction, you agree that the following terms and conditions apply to this transaction (along with the Billing and Payment terms and conditions established by Copyright Clearance Center, Inc. ("CCC"), at the time that you opened your Rightslink account and that are available at any time at <http://myaccount.copyright.com>).

GENERAL TERMS

2. Elsevier hereby grants you permission to reproduce the aforementioned material subject to the terms and conditions indicated.

3. Acknowledgement: If any part of the material to be used (for example, figures) has appeared in our publication with credit or acknowledgement to another source, permission must also be sought from that source. If such permission is not obtained then that material may not be included in your publication/copies. Suitable acknowledgement to the source must be made, either as a footnote or in a reference list at the end of your publication, as follows:

"Reprinted from Publication title, Vol /edition number, Author(s), Title of article / title of chapter, Pages No., Copyright (Year), with permission from Elsevier [OR APPLICABLE SOCIETY COPYRIGHT OWNER]." Also Lancet special credit - "Reprinted from The Lancet, Vol. number, Author(s), Title of article, Pages No., Copyright (Year), with permission from Elsevier."

4. Reproduction of this material is confined to the purpose and/or media for which permission is hereby given.

5. Altering/Modifying Material: Not Permitted. However figures and illustrations may be altered/adapted minimally to serve your work. Any other abbreviations, additions, deletions

and/or any other alterations shall be made only with prior written authorization of Elsevier Ltd. (Please contact Elsevier at permissions@elsevier.com)

6. If the permission fee for the requested use of our material is waived in this instance, please be advised that your future requests for Elsevier materials may attract a fee.

7. **Reservation of Rights:** Publisher reserves all rights not specifically granted in the combination of (i) the license details provided by you and accepted in the course of this licensing transaction, (ii) these terms and conditions and (iii) CCC's Billing and Payment terms and conditions.

8. **License Contingent Upon Payment:** While you may exercise the rights licensed immediately upon issuance of the license at the end of the licensing process for the transaction, provided that you have disclosed complete and accurate details of your proposed use, no license is finally effective unless and until full payment is received from you (either by publisher or by CCC) as provided in CCC's Billing and Payment terms and conditions. If full payment is not received on a timely basis, then any license preliminarily granted shall be deemed automatically revoked and shall be void as if never granted. Further, in the event that you breach any of these terms and conditions or any of CCC's Billing and Payment terms and conditions, the license is automatically revoked and shall be void as if never granted. Use of materials as described in a revoked license, as well as any use of the materials beyond the scope of an unrevoked license, may constitute copyright infringement and publisher reserves the right to take any and all action to protect its copyright in the materials.

9. **Warranties:** Publisher makes no representations or warranties with respect to the licensed material.

10. **Indemnity:** You hereby indemnify and agree to hold harmless publisher and CCC, and their respective officers, directors, employees and agents, from and against any and all claims arising out of your use of the licensed material other than as specifically authorized pursuant to this license.

11. **No Transfer of License:** This license is personal to you and may not be sublicensed, assigned, or transferred by you to any other person without publisher's written permission.

12. **No Amendment Except in Writing:** This license may not be amended except in a writing signed by both parties (or, in the case of publisher, by CCC on publisher's behalf).

13. **Objection to Contrary Terms:** Publisher hereby objects to any terms contained in any purchase order, acknowledgment, check endorsement or other writing prepared by you, which terms are inconsistent with these terms and conditions or CCC's Billing and Payment terms and conditions. These terms and conditions, together with CCC's Billing and Payment terms and conditions (which are incorporated herein), comprise the entire agreement between you and publisher (and CCC) concerning this licensing transaction. In the event of any conflict between your obligations established by these terms and

conditions and those established by CCC's Billing and Payment terms and conditions, these terms and conditions shall control.

14. **Revocation:** Elsevier or Copyright Clearance Center may deny the permissions described in this License at their sole discretion, for any reason or no reason, with a full refund payable to you. Notice of such denial will be made using the contact information provided by you. Failure to receive such notice will not alter or invalidate the denial. In no event will Elsevier or Copyright Clearance Center be responsible or liable for any costs, expenses or damage incurred by you as a result of a denial of your permission request, other than a refund of the amount(s) paid by you to Elsevier and/or Copyright Clearance Center for denied permissions.

LIMITED LICENSE

The following terms and conditions apply only to specific license types:

15. **Translation:** This permission is granted for non-exclusive world **English** rights only unless your license was granted for translation rights. If you licensed translation rights you may only translate this content into the languages you requested. A professional translator must perform all translations and reproduce the content word for word preserving the integrity of the article. If this license is to re-use 1 or 2 figures then permission is granted for non-exclusive world rights in all languages.

16. **Posting licensed content on any Website:** The following terms and conditions apply as follows: Licensing material from an Elsevier journal: All content posted to the web site must maintain the copyright information line on the bottom of each image; A hyper-text must be included to the Homepage of the journal from which you are licensing at <http://www.sciencedirect.com/science/journal/xxxxx> or the Elsevier homepage for books at <http://www.elsevier.com>; Central Storage: This license does not include permission for a scanned version of the material to be stored in a central repository such as that provided by Heron/XanEdu.

Licensing material from an Elsevier book: A hyper-text link must be included to the Elsevier homepage at <http://www.elsevier.com> . All content posted to the web site must maintain the copyright information line on the bottom of each image.

Posting licensed content on Electronic reserve: In addition to the above the following clauses are applicable: The web site must be password-protected and made available only to bona fide students registered on a relevant course. This permission is granted for 1 year only. You may obtain a new license for future website posting.

17. **For journal authors:** the following clauses are applicable in addition to the above:

Preprints:

A preprint is an author's own write-up of research results and analysis, it has not been peer-reviewed, nor has it had any other value added to it by a publisher (such as formatting, copyright, technical enhancement etc.).

Authors can share their preprints anywhere at any time. Preprints should not be added to or enhanced in any way in order to appear more like, or to substitute for, the final versions of articles however authors can update their preprints on arXiv or RePEc with their Accepted Author Manuscript (see below).

If accepted for publication, we encourage authors to link from the preprint to their formal publication via its DOI. Millions of researchers have access to the formal publications on ScienceDirect, and so links will help users to find, access, cite and use the best available version. Please note that Cell Press, The Lancet and some society-owned have different preprint policies. Information on these policies is available on the journal homepage.

Accepted Author Manuscripts: An accepted author manuscript is the manuscript of an article that has been accepted for publication and which typically includes author-incorporated changes suggested during submission, peer review and editor-author communications.

Authors can share their accepted author manuscript:

- – immediately
 - via their non-commercial person homepage or blog
 - by updating a preprint in arXiv or RePEc with the accepted manuscript
 - via their research institute or institutional repository for internal institutional uses or as part of an invitation-only research collaboration work-group
 - directly by providing copies to their students or to research collaborators for their personal use
 - for private scholarly sharing as part of an invitation-only work group on commercial sites with which Elsevier has an agreement
- – after the embargo period
 - via non-commercial hosting platforms such as their institutional repository
 - via commercial sites with which Elsevier has an agreement

In all cases accepted manuscripts should:

- – link to the formal publication via its DOI
- – bear a CC-BY-NC-ND license - this is easy to do
- – if aggregated with other manuscripts, for example in a repository or other site, be shared in alignment with our hosting policy not be added to or enhanced in any way to appear more like, or to substitute for, the published journal article.

Published journal article (JPA): A published journal article (PJA) is the definitive final record of published research that appears or will appear in the journal and embodies all value-adding publishing activities including peer review co-ordination, copy-editing, formatting, (if relevant) pagination and online enrichment.

Policies for sharing publishing journal articles differ for subscription and gold open access articles:

Subscription Articles: If you are an author, please share a link to your article rather than the full-text. Millions of researchers have access to the formal publications on ScienceDirect, and so links will help your users to find, access, cite, and use the best available version.

Theses and dissertations which contain embedded PJAs as part of the formal submission can be posted publicly by the awarding institution with DOI links back to the formal publications on ScienceDirect.

If you are affiliated with a library that subscribes to ScienceDirect you have additional private sharing rights for others' research accessed under that agreement. This includes use for classroom teaching and internal training at the institution (including use in course packs and courseware programs), and inclusion of the article for grant funding purposes.

Gold Open Access Articles: May be shared according to the author-selected end-user license and should contain a [CrossMark logo](#), the end user license, and a DOI link to the formal publication on ScienceDirect.

Please refer to Elsevier's [posting policy](#) for further information.

18. **For book authors** the following clauses are applicable in addition to the above: Authors are permitted to place a brief summary of their work online only. You are not allowed to download and post the published electronic version of your chapter, nor may you scan the printed edition to create an electronic version. **Posting to a repository:** Authors are permitted to post a summary of their chapter only in their institution's repository.

19. **Thesis/Dissertation:** If your license is for use in a thesis/dissertation your thesis may be submitted to your institution in either print or electronic form. Should your thesis be published commercially, please reapply for permission. These requirements include permission for the Library and Archives of Canada to supply single copies, on demand, of the complete thesis and include permission for Proquest/UMI to supply single copies, on demand, of the complete thesis. Should your thesis be published commercially, please reapply for permission. Theses and dissertations which contain embedded PJAs as part of the formal submission can be posted publicly by the awarding institution with DOI links back to the formal publications on ScienceDirect.

Elsevier Open Access Terms and Conditions

You can publish open access with Elsevier in hundreds of open access journals or in nearly 2000 established subscription journals that support open access publishing. Permitted third party re-use of these open access articles is defined by the author's choice of Creative Commons user license. See our [open access license policy](#) for more information.

Terms & Conditions applicable to all Open Access articles published with Elsevier:

Any reuse of the article must not represent the author as endorsing the adaptation of the article nor should the article be modified in such a way as to damage the author's honour or reputation. If any changes have been made, such changes must be clearly indicated.

The author(s) must be appropriately credited and we ask that you include the end user license and a DOI link to the formal publication on ScienceDirect.

If any part of the material to be used (for example, figures) has appeared in our publication with credit or acknowledgement to another source it is the responsibility of the user to ensure their reuse complies with the terms and conditions determined by the rights holder.

Additional Terms & Conditions applicable to each Creative Commons user license:

CC BY: The CC-BY license allows users to copy, to create extracts, abstracts and new works from the Article, to alter and revise the Article and to make commercial use of the Article (including reuse and/or resale of the Article by commercial entities), provided the user gives appropriate credit (with a link to the formal publication through the relevant DOI), provides a link to the license, indicates if changes were made and the licensor is not represented as endorsing the use made of the work. The full details of the license are available at <http://creativecommons.org/licenses/by/4.0>.

CC BY NC SA: The CC BY-NC-SA license allows users to copy, to create extracts, abstracts and new works from the Article, to alter and revise the Article, provided this is not done for commercial purposes, and that the user gives appropriate credit (with a link to the formal publication through the relevant DOI), provides a link to the license, indicates if changes were made and the licensor is not represented as endorsing the use made of the work. Further, any new works must be made available on the same conditions. The full details of the license are available at <http://creativecommons.org/licenses/by-nc-sa/4.0>.

CC BY NC ND: The CC BY-NC-ND license allows users to copy and distribute the Article, provided this is not done for commercial purposes and further does not permit distribution of the Article if it is changed or edited in any way, and provided the user gives appropriate credit (with a link to the formal publication through the relevant DOI), provides a link to the license, and that the licensor is not represented as endorsing the use made of the work. The full details of the license are available at

<http://creativecommons.org/licenses/by-nc-nd/4.0>. Any commercial reuse of Open Access articles published with a CC BY NC SA or CC BY NC ND license requires permission from Elsevier and will be subject to a fee.

Commercial reuse includes:

- – Associating advertising with the full text of the Article
- – Charging fees for document delivery or access
- – Article aggregation
- – Systematic distribution via e-mail lists or share buttons

Posting or linking by commercial companies for use by customers of those companies.

20. Other Conditions:

Questions? customercare@copyright.com or +1-855-239-3415 (toll free in the US) or +1-978-646-2777.

Gratis licenses (referencing \$0 in the Total field) are free. Please retain this printable license for your reference. No payment is required.

AIP PUBLISHING LLC LICENSE
TERMS AND CONDITIONS

Apr 14, 2015

All payments must be made in full to CCC. For payment instructions, please see information listed at the bottom of this form.

License Number	3607411403994
Order Date	Apr 13, 2015
Publisher	AIP Publishing LLC
Publication	Journal of Applied Physics
Article Title	Carbon nanocapsules and single-layered nanotubes produced with platinum-group metals (Ru, Rh, Pd, Os, Ir, Pt) by arc discharge
Author	Yahachi Saito,Keishi Nishikubo,Kenichiro Kawabata, et al.
Online Publication Date	Sep 1, 1996
Volume number	80
Issue number	5
Type of Use	Thesis/Dissertation
Requestor type	Student
Format	Print and electronic
Portion	Figure/Table
Number of figures/tables	1
Title of your thesis / dissertation	Investigation of Dye-Sensitized Solar Cell Performance with Single Chirality Semiconducting Carbon Nanotubes
Expected completion date	Apr 2015
Estimated size (number of pages)	160
Total	0.00 CAD

Terms and Conditions

AIP Publishing LLC -- Terms and Conditions: Permissions Uses

AIP Publishing LLC ("AIPP") hereby grants to you the non-exclusive right and license to use and/or distribute the Material according to the use specified in your order, on a one-time basis, for the specified term, with a maximum distribution equal to the number that you have ordered. Any links or other content accompanying the Material are not the subject of this license.

1. You agree to include the following copyright and permission notice with the reproduction of the Material:"Reprinted with permission from [FULL CITATION]. Copyright [PUBLICATION YEAR], AIP Publishing LLC." For an article, the

copyright and permission notice must be printed on the first page of the article or book chapter. For photographs, covers, or tables, the copyright and permission notice may appear with the Material, in a footnote, or in the reference list.

2. If you have licensed reuse of a figure, photograph, cover, or table, it is your responsibility to ensure that the material is original to AIPP and does not contain the copyright of another entity, and that the copyright notice of the figure, photograph, cover, or table does not indicate that it was reprinted by AIPP, with permission, from another source. Under no circumstances does AIPP, purport or intend to grant permission to reuse material to which it does not hold copyright.
3. You may not alter or modify the Material in any manner. You may translate the Material into another language only if you have licensed translation rights. You may not use the Material for promotional purposes. AIPP reserves all rights not specifically granted herein.
4. The foregoing license shall not take effect unless and until AIPP or its agent, Copyright Clearance Center, receives the Payment in accordance with Copyright Clearance Center Billing and Payment Terms and Conditions, which are incorporated herein by reference.
5. AIPP or the Copyright Clearance Center may, within two business days of granting this license, revoke the license for any reason whatsoever, with a full refund payable to you. Should you violate the terms of this license at any time, AIPP, AIP Publishing LLC, or Copyright Clearance Center may revoke the license with no refund to you. Notice of such revocation will be made using the contact information provided by you. Failure to receive such notice will not nullify the revocation.
6. AIPP makes no representations or warranties with respect to the Material. You agree to indemnify and hold harmless AIPP, AIP Publishing LLC, and their officers, directors, employees or agents from and against any and all claims arising out of your use of the Material other than as specifically authorized herein.
7. The permission granted herein is personal to you and is not transferable or assignable without the prior written permission of AIPP. This license may not be amended except in a writing signed by the party to be charged.
8. If purchase orders, acknowledgments or check endorsements are issued on any forms containing terms and conditions which are inconsistent with these provisions, such inconsistent terms and conditions shall be of no force and effect. This document, including the CCC Billing and Payment Terms and Conditions, shall be the entire agreement between the parties relating to the subject matter hereof.

This Agreement shall be governed by and construed in accordance with the laws of the State of New York. Both parties hereby submit to the jurisdiction of the courts of New York County for purposes of resolving any disputes that may arise hereunder.

Questions? customercare@copyright.com or +1-855-239-3415 (toll free in the US) or +1-978-646-2777.

Gratis licenses (referencing \$0 in the Total field) are free. Please retain this printable license for your reference. No payment is required.

ELSEVIER LICENSE
TERMS AND CONDITIONS

Apr 14, 2015

This is a License Agreement between Victoria Davis ("You") and Elsevier ("Elsevier") provided by Copyright Clearance Center ("CCC"). The license consists of your order details, the terms and conditions provided by Elsevier, and the payment terms and conditions.

All payments must be made in full to CCC. For payment instructions, please see information listed at the bottom of this form.

Supplier	Elsevier Limited The Boulevard, Langford Lane Kidlington, Oxford, OX5 1GB, UK
Registered Company Number	1982084
Customer name	Victoria Davis
Customer address	2000 Simcoe Street North Oshawa, ON L1H 7K4
License number	3607420365561
License date	Apr 13, 2015
Licensed content publisher	Elsevier
Licensed content publication	Thin Solid Films
Licensed content title	Growth of well-aligned carbon nanotubes by RF-DC plasma chemical vapor deposition
Licensed content author	None
Licensed content date	30 April 2010
Licensed content volume number	518
Licensed content issue number	13
Number of pages	3
Start Page	3506
End Page	3508
Type of Use	reuse in a thesis/dissertation
Intended publisher of new work	other
Portion	figures/tables/illustrations
Number of figures/tables/illustrations	1
Format	both print and electronic
Are you the author of this Elsevier article?	No
Will you be translating?	No

Order reference number	44
Original figure numbers	Figure 1
Title of your thesis/dissertation	Investigation of Dye-Sensitized Solar Cell Performance with Single Chirality Semiconducting Carbon Nanotubes
Expected completion date	Apr 2015
Estimated size (number of pages)	160
Elsevier VAT number	GB 494 6272 12
Permissions price	0.00 USD
VAT/Local Sales Tax	0.00 USD / 0.00 GBP
Total	0.00 USD
Terms and Conditions	

INTRODUCTION

1. The publisher for this copyrighted material is Elsevier. By clicking "accept" in connection with completing this licensing transaction, you agree that the following terms and conditions apply to this transaction (along with the Billing and Payment terms and conditions established by Copyright Clearance Center, Inc. ("CCC"), at the time that you opened your Rightslink account and that are available at any time at <http://myaccount.copyright.com>).

GENERAL TERMS

2. Elsevier hereby grants you permission to reproduce the aforementioned material subject to the terms and conditions indicated.

3. Acknowledgement: If any part of the material to be used (for example, figures) has appeared in our publication with credit or acknowledgement to another source, permission must also be sought from that source. If such permission is not obtained then that material may not be included in your publication/copies. Suitable acknowledgement to the source must be made, either as a footnote or in a reference list at the end of your publication, as follows:

"Reprinted from Publication title, Vol /edition number, Author(s), Title of article / title of chapter, Pages No., Copyright (Year), with permission from Elsevier [OR APPLICABLE SOCIETY COPYRIGHT OWNER]." Also Lancet special credit - "Reprinted from The Lancet, Vol. number, Author(s), Title of article, Pages No., Copyright (Year), with permission from Elsevier."

4. Reproduction of this material is confined to the purpose and/or media for which permission is hereby given.

5. Altering/Modifying Material: Not Permitted. However figures and illustrations may be altered/adapted minimally to serve your work. Any other abbreviations, additions, deletions

and/or any other alterations shall be made only with prior written authorization of Elsevier Ltd. (Please contact Elsevier at permissions@elsevier.com)

6. If the permission fee for the requested use of our material is waived in this instance, please be advised that your future requests for Elsevier materials may attract a fee.

7. **Reservation of Rights:** Publisher reserves all rights not specifically granted in the combination of (i) the license details provided by you and accepted in the course of this licensing transaction, (ii) these terms and conditions and (iii) CCC's Billing and Payment terms and conditions.

8. **License Contingent Upon Payment:** While you may exercise the rights licensed immediately upon issuance of the license at the end of the licensing process for the transaction, provided that you have disclosed complete and accurate details of your proposed use, no license is finally effective unless and until full payment is received from you (either by publisher or by CCC) as provided in CCC's Billing and Payment terms and conditions. If full payment is not received on a timely basis, then any license preliminarily granted shall be deemed automatically revoked and shall be void as if never granted. Further, in the event that you breach any of these terms and conditions or any of CCC's Billing and Payment terms and conditions, the license is automatically revoked and shall be void as if never granted. Use of materials as described in a revoked license, as well as any use of the materials beyond the scope of an unrevoked license, may constitute copyright infringement and publisher reserves the right to take any and all action to protect its copyright in the materials.

9. **Warranties:** Publisher makes no representations or warranties with respect to the licensed material.

10. **Indemnity:** You hereby indemnify and agree to hold harmless publisher and CCC, and their respective officers, directors, employees and agents, from and against any and all claims arising out of your use of the licensed material other than as specifically authorized pursuant to this license.

11. **No Transfer of License:** This license is personal to you and may not be sublicensed, assigned, or transferred by you to any other person without publisher's written permission.

12. **No Amendment Except in Writing:** This license may not be amended except in a writing signed by both parties (or, in the case of publisher, by CCC on publisher's behalf).

13. **Objection to Contrary Terms:** Publisher hereby objects to any terms contained in any purchase order, acknowledgment, check endorsement or other writing prepared by you, which terms are inconsistent with these terms and conditions or CCC's Billing and Payment terms and conditions. These terms and conditions, together with CCC's Billing and Payment terms and conditions (which are incorporated herein), comprise the entire agreement between you and publisher (and CCC) concerning this licensing transaction. In the event of any conflict between your obligations established by these terms and

conditions and those established by CCC's Billing and Payment terms and conditions, these terms and conditions shall control.

14. **Revocation:** Elsevier or Copyright Clearance Center may deny the permissions described in this License at their sole discretion, for any reason or no reason, with a full refund payable to you. Notice of such denial will be made using the contact information provided by you. Failure to receive such notice will not alter or invalidate the denial. In no event will Elsevier or Copyright Clearance Center be responsible or liable for any costs, expenses or damage incurred by you as a result of a denial of your permission request, other than a refund of the amount(s) paid by you to Elsevier and/or Copyright Clearance Center for denied permissions.

LIMITED LICENSE

The following terms and conditions apply only to specific license types:

15. **Translation:** This permission is granted for non-exclusive world **English** rights only unless your license was granted for translation rights. If you licensed translation rights you may only translate this content into the languages you requested. A professional translator must perform all translations and reproduce the content word for word preserving the integrity of the article. If this license is to re-use 1 or 2 figures then permission is granted for non-exclusive world rights in all languages.

16. **Posting licensed content on any Website:** The following terms and conditions apply as follows: Licensing material from an Elsevier journal: All content posted to the web site must maintain the copyright information line on the bottom of each image; A hyper-text must be included to the Homepage of the journal from which you are licensing at <http://www.sciencedirect.com/science/journal/xxxxx> or the Elsevier homepage for books at <http://www.elsevier.com>; Central Storage: This license does not include permission for a scanned version of the material to be stored in a central repository such as that provided by Heron/XanEdu.

Licensing material from an Elsevier book: A hyper-text link must be included to the Elsevier homepage at <http://www.elsevier.com> . All content posted to the web site must maintain the copyright information line on the bottom of each image.

Posting licensed content on Electronic reserve: In addition to the above the following clauses are applicable: The web site must be password-protected and made available only to bona fide students registered on a relevant course. This permission is granted for 1 year only. You may obtain a new license for future website posting.

17. **For journal authors:** the following clauses are applicable in addition to the above:

Preprints:

A preprint is an author's own write-up of research results and analysis, it has not been peer-reviewed, nor has it had any other value added to it by a publisher (such as formatting, copyright, technical enhancement etc.).

Authors can share their preprints anywhere at any time. Preprints should not be added to or enhanced in any way in order to appear more like, or to substitute for, the final versions of articles however authors can update their preprints on arXiv or RePEc with their Accepted Author Manuscript (see below).

If accepted for publication, we encourage authors to link from the preprint to their formal publication via its DOI. Millions of researchers have access to the formal publications on ScienceDirect, and so links will help users to find, access, cite and use the best available version. Please note that Cell Press, The Lancet and some society-owned have different preprint policies. Information on these policies is available on the journal homepage.

Accepted Author Manuscripts: An accepted author manuscript is the manuscript of an article that has been accepted for publication and which typically includes author-incorporated changes suggested during submission, peer review and editor-author communications.

Authors can share their accepted author manuscript:

- – immediately
 - via their non-commercial person homepage or blog
 - by updating a preprint in arXiv or RePEc with the accepted manuscript
 - via their research institute or institutional repository for internal institutional uses or as part of an invitation-only research collaboration work-group
 - directly by providing copies to their students or to research collaborators for their personal use
 - for private scholarly sharing as part of an invitation-only work group on commercial sites with which Elsevier has an agreement
- – after the embargo period
 - via non-commercial hosting platforms such as their institutional repository
 - via commercial sites with which Elsevier has an agreement

In all cases accepted manuscripts should:

- – link to the formal publication via its DOI
- – bear a CC-BY-NC-ND license - this is easy to do
- – if aggregated with other manuscripts, for example in a repository or other site, be shared in alignment with our hosting policy not be added to or enhanced in any way to appear more like, or to substitute for, the published journal article.

Published journal article (JPA): A published journal article (PJA) is the definitive final record of published research that appears or will appear in the journal and embodies all value-adding publishing activities including peer review co-ordination, copy-editing, formatting, (if relevant) pagination and online enrichment.

Policies for sharing publishing journal articles differ for subscription and gold open access articles:

Subscription Articles: If you are an author, please share a link to your article rather than the full-text. Millions of researchers have access to the formal publications on ScienceDirect, and so links will help your users to find, access, cite, and use the best available version.

Theses and dissertations which contain embedded PJAs as part of the formal submission can be posted publicly by the awarding institution with DOI links back to the formal publications on ScienceDirect.

If you are affiliated with a library that subscribes to ScienceDirect you have additional private sharing rights for others' research accessed under that agreement. This includes use for classroom teaching and internal training at the institution (including use in course packs and courseware programs), and inclusion of the article for grant funding purposes.

Gold Open Access Articles: May be shared according to the author-selected end-user license and should contain a [CrossMark logo](#), the end user license, and a DOI link to the formal publication on ScienceDirect.

Please refer to Elsevier's [posting policy](#) for further information.

18. **For book authors** the following clauses are applicable in addition to the above: Authors are permitted to place a brief summary of their work online only. You are not allowed to download and post the published electronic version of your chapter, nor may you scan the printed edition to create an electronic version. **Posting to a repository:** Authors are permitted to post a summary of their chapter only in their institution's repository.

19. **Thesis/Dissertation:** If your license is for use in a thesis/dissertation your thesis may be submitted to your institution in either print or electronic form. Should your thesis be published commercially, please reapply for permission. These requirements include permission for the Library and Archives of Canada to supply single copies, on demand, of the complete thesis and include permission for Proquest/UMI to supply single copies, on demand, of the complete thesis. Should your thesis be published commercially, please reapply for permission. Theses and dissertations which contain embedded PJAs as part of the formal submission can be posted publicly by the awarding institution with DOI links back to the formal publications on ScienceDirect.

Elsevier Open Access Terms and Conditions

You can publish open access with Elsevier in hundreds of open access journals or in nearly 2000 established subscription journals that support open access publishing. Permitted third party re-use of these open access articles is defined by the author's choice of Creative Commons user license. See our [open access license policy](#) for more information.

Terms & Conditions applicable to all Open Access articles published with Elsevier:

Any reuse of the article must not represent the author as endorsing the adaptation of the article nor should the article be modified in such a way as to damage the author's honour or reputation. If any changes have been made, such changes must be clearly indicated.

The author(s) must be appropriately credited and we ask that you include the end user license and a DOI link to the formal publication on ScienceDirect.

If any part of the material to be used (for example, figures) has appeared in our publication with credit or acknowledgement to another source it is the responsibility of the user to ensure their reuse complies with the terms and conditions determined by the rights holder.

Additional Terms & Conditions applicable to each Creative Commons user license:

CC BY: The CC-BY license allows users to copy, to create extracts, abstracts and new works from the Article, to alter and revise the Article and to make commercial use of the Article (including reuse and/or resale of the Article by commercial entities), provided the user gives appropriate credit (with a link to the formal publication through the relevant DOI), provides a link to the license, indicates if changes were made and the licensor is not represented as endorsing the use made of the work. The full details of the license are available at <http://creativecommons.org/licenses/by/4.0>.

CC BY NC SA: The CC BY-NC-SA license allows users to copy, to create extracts, abstracts and new works from the Article, to alter and revise the Article, provided this is not done for commercial purposes, and that the user gives appropriate credit (with a link to the formal publication through the relevant DOI), provides a link to the license, indicates if changes were made and the licensor is not represented as endorsing the use made of the work. Further, any new works must be made available on the same conditions. The full details of the license are available at <http://creativecommons.org/licenses/by-nc-sa/4.0>.

CC BY NC ND: The CC BY-NC-ND license allows users to copy and distribute the Article, provided this is not done for commercial purposes and further does not permit distribution of the Article if it is changed or edited in any way, and provided the user gives appropriate credit (with a link to the formal publication through the relevant DOI), provides a link to the license, and that the licensor is not represented as endorsing the use made of the work. The full details of the license are available at

<http://creativecommons.org/licenses/by-nc-nd/4.0>. Any commercial reuse of Open Access articles published with a CC BY NC SA or CC BY NC ND license requires permission from Elsevier and will be subject to a fee.

Commercial reuse includes:

- – Associating advertising with the full text of the Article
- – Charging fees for document delivery or access
- – Article aggregation
- – Systematic distribution via e-mail lists or share buttons

Posting or linking by commercial companies for use by customers of those companies.

20. Other Conditions:

Questions? customercare@copyright.com or +1-855-239-3415 (toll free in the US) or +1-978-646-2777.

Gratis licenses (referencing \$0 in the Total field) are free. Please retain this printable license for your reference. No payment is required.

ELSEVIER LICENSE
TERMS AND CONDITIONS

Apr 14, 2015

This is a License Agreement between Victoria Davis ("You") and Elsevier ("Elsevier") provided by Copyright Clearance Center ("CCC"). The license consists of your order details, the terms and conditions provided by Elsevier, and the payment terms and conditions.

All payments must be made in full to CCC. For payment instructions, please see information listed at the bottom of this form.

Supplier	Elsevier Limited The Boulevard,Langford Lane Kidlington,Oxford,OX5 1GB,UK
Registered Company Number	1982084
Customer name	Victoria Davis
Customer address	2000 Simcoe Street North Oshawa, ON L1H 7K4
License number	3607420522738
License date	Apr 13, 2015
Licensed content publisher	Elsevier
Licensed content publication	Chemical Physics Letters
Licensed content title	Gas-phase catalytic growth of single-walled carbon nanotubes from carbon monoxide
Licensed content author	Pavel Nikolaev,Michael J Bronikowski,R.Kelley Bradley,Frank Rohmund,Daniel T Colbert,K.A Smith,Richard E Smalley
Licensed content date	5 November 1999
Licensed content volume number	313
Licensed content issue number	1-2
Number of pages	7
Start Page	91
End Page	97
Type of Use	reuse in a thesis/dissertation
Intended publisher of new work	other
Portion	figures/tables/illustrations
Number of figures/tables/illustrations	1
Format	both print and electronic
Are you the author of this Elsevier	No

article?	
Will you be translating?	No
Order reference number	47
Original figure numbers	Figure 1
Title of your thesis/dissertation	Investigation of Dye-Sensitized Solar Cell Performance with Single Chirality Semiconducting Carbon Nanotubes
Expected completion date	Apr 2015
Estimated size (number of pages)	160
Elsevier VAT number	GB 494 6272 12
Permissions price	0.00 USD
VAT/Local Sales Tax	0.00 USD / 0.00 GBP
Total	0.00 USD
Terms and Conditions	

INTRODUCTION

1. The publisher for this copyrighted material is Elsevier. By clicking "accept" in connection with completing this licensing transaction, you agree that the following terms and conditions apply to this transaction (along with the Billing and Payment terms and conditions established by Copyright Clearance Center, Inc. ("CCC"), at the time that you opened your Rightslink account and that are available at any time at <http://myaccount.copyright.com>).

GENERAL TERMS

2. Elsevier hereby grants you permission to reproduce the aforementioned material subject to the terms and conditions indicated.

3. Acknowledgement: If any part of the material to be used (for example, figures) has appeared in our publication with credit or acknowledgement to another source, permission must also be sought from that source. If such permission is not obtained then that material may not be included in your publication/copies. Suitable acknowledgement to the source must be made, either as a footnote or in a reference list at the end of your publication, as follows:

"Reprinted from Publication title, Vol /edition number, Author(s), Title of article / title of chapter, Pages No., Copyright (Year), with permission from Elsevier [OR APPLICABLE SOCIETY COPYRIGHT OWNER]." Also Lancet special credit - "Reprinted from The Lancet, Vol. number, Author(s), Title of article, Pages No., Copyright (Year), with permission from Elsevier."

4. Reproduction of this material is confined to the purpose and/or media for which permission is hereby given.

5. **Altering/Modifying Material: Not Permitted.** However figures and illustrations may be altered/adapted minimally to serve your work. Any other abbreviations, additions, deletions and/or any other alterations shall be made only with prior written authorization of Elsevier Ltd. (Please contact Elsevier at permissions@elsevier.com)

6. If the permission fee for the requested use of our material is waived in this instance, please be advised that your future requests for Elsevier materials may attract a fee.

7. **Reservation of Rights:** Publisher reserves all rights not specifically granted in the combination of (i) the license details provided by you and accepted in the course of this licensing transaction, (ii) these terms and conditions and (iii) CCC's Billing and Payment terms and conditions.

8. **License Contingent Upon Payment:** While you may exercise the rights licensed immediately upon issuance of the license at the end of the licensing process for the transaction, provided that you have disclosed complete and accurate details of your proposed use, no license is finally effective unless and until full payment is received from you (either by publisher or by CCC) as provided in CCC's Billing and Payment terms and conditions. If full payment is not received on a timely basis, then any license preliminarily granted shall be deemed automatically revoked and shall be void as if never granted. Further, in the event that you breach any of these terms and conditions or any of CCC's Billing and Payment terms and conditions, the license is automatically revoked and shall be void as if never granted. Use of materials as described in a revoked license, as well as any use of the materials beyond the scope of an unrevoked license, may constitute copyright infringement and publisher reserves the right to take any and all action to protect its copyright in the materials.

9. **Warranties:** Publisher makes no representations or warranties with respect to the licensed material.

10. **Indemnity:** You hereby indemnify and agree to hold harmless publisher and CCC, and their respective officers, directors, employees and agents, from and against any and all claims arising out of your use of the licensed material other than as specifically authorized pursuant to this license.

11. **No Transfer of License:** This license is personal to you and may not be sublicensed, assigned, or transferred by you to any other person without publisher's written permission.

12. **No Amendment Except in Writing:** This license may not be amended except in a writing signed by both parties (or, in the case of publisher, by CCC on publisher's behalf).

13. **Objection to Contrary Terms:** Publisher hereby objects to any terms contained in any purchase order, acknowledgment, check endorsement or other writing prepared by you, which terms are inconsistent with these terms and conditions or CCC's Billing and Payment terms and conditions. These terms and conditions, together with CCC's Billing and Payment terms and conditions (which are incorporated herein), comprise the entire

agreement between you and publisher (and CCC) concerning this licensing transaction. In the event of any conflict between your obligations established by these terms and conditions and those established by CCC's Billing and Payment terms and conditions, these terms and conditions shall control.

14. **Revocation:** Elsevier or Copyright Clearance Center may deny the permissions described in this License at their sole discretion, for any reason or no reason, with a full refund payable to you. Notice of such denial will be made using the contact information provided by you. Failure to receive such notice will not alter or invalidate the denial. In no event will Elsevier or Copyright Clearance Center be responsible or liable for any costs, expenses or damage incurred by you as a result of a denial of your permission request, other than a refund of the amount(s) paid by you to Elsevier and/or Copyright Clearance Center for denied permissions.

LIMITED LICENSE

The following terms and conditions apply only to specific license types:

15. **Translation:** This permission is granted for non-exclusive world **English** rights only unless your license was granted for translation rights. If you licensed translation rights you may only translate this content into the languages you requested. A professional translator must perform all translations and reproduce the content word for word preserving the integrity of the article. If this license is to re-use 1 or 2 figures then permission is granted for non-exclusive world rights in all languages.

16. **Posting licensed content on any Website:** The following terms and conditions apply as follows: Licensing material from an Elsevier journal: All content posted to the web site must maintain the copyright information line on the bottom of each image; A hyper-text must be included to the Homepage of the journal from which you are licensing at <http://www.sciencedirect.com/science/journal/xxxxx> or the Elsevier homepage for books at <http://www.elsevier.com>; Central Storage: This license does not include permission for a scanned version of the material to be stored in a central repository such as that provided by Heron/XanEdu.

Licensing material from an Elsevier book: A hyper-text link must be included to the Elsevier homepage at <http://www.elsevier.com>. All content posted to the web site must maintain the copyright information line on the bottom of each image.

Posting licensed content on Electronic reserve: In addition to the above the following clauses are applicable: The web site must be password-protected and made available only to bona fide students registered on a relevant course. This permission is granted for 1 year only. You may obtain a new license for future website posting.

17. **For journal authors:** the following clauses are applicable in addition to the above:

Preprints:

A preprint is an author's own write-up of research results and analysis, it has not been peer-reviewed, nor has it had any other value added to it by a publisher (such as formatting, copyright, technical enhancement etc.).

Authors can share their preprints anywhere at any time. Preprints should not be added to or enhanced in any way in order to appear more like, or to substitute for, the final versions of articles however authors can update their preprints on arXiv or RePEc with their Accepted Author Manuscript (see below).

If accepted for publication, we encourage authors to link from the preprint to their formal publication via its DOI. Millions of researchers have access to the formal publications on ScienceDirect, and so links will help users to find, access, cite and use the best available version. Please note that Cell Press, The Lancet and some society-owned have different preprint policies. Information on these policies is available on the journal homepage.

Accepted Author Manuscripts: An accepted author manuscript is the manuscript of an article that has been accepted for publication and which typically includes author-incorporated changes suggested during submission, peer review and editor-author communications.

Authors can share their accepted author manuscript:

- – immediately
 - via their non-commercial person homepage or blog
 - by updating a preprint in arXiv or RePEc with the accepted manuscript
 - via their research institute or institutional repository for internal institutional uses or as part of an invitation-only research collaboration work-group
 - directly by providing copies to their students or to research collaborators for their personal use
 - for private scholarly sharing as part of an invitation-only work group on commercial sites with which Elsevier has an agreement
- – after the embargo period
 - via non-commercial hosting platforms such as their institutional repository
 - via commercial sites with which Elsevier has an agreement

In all cases accepted manuscripts should:

- – link to the formal publication via its DOI
- – bear a CC-BY-NC-ND license - this is easy to do
- – if aggregated with other manuscripts, for example in a repository or other site, be shared in alignment with our hosting policy not be added to or enhanced in any

way to appear more like, or to substitute for, the published journal article.

Published journal article (JPA): A published journal article (PJA) is the definitive final record of published research that appears or will appear in the journal and embodies all value-adding publishing activities including peer review co-ordination, copy-editing, formatting, (if relevant) pagination and online enrichment.

Policies for sharing publishing journal articles differ for subscription and gold open access articles:

Subscription Articles: If you are an author, please share a link to your article rather than the full-text. Millions of researchers have access to the formal publications on ScienceDirect, and so links will help your users to find, access, cite, and use the best available version.

Theses and dissertations which contain embedded PJAs as part of the formal submission can be posted publicly by the awarding institution with DOI links back to the formal publications on ScienceDirect.

If you are affiliated with a library that subscribes to ScienceDirect you have additional private sharing rights for others' research accessed under that agreement. This includes use for classroom teaching and internal training at the institution (including use in course packs and courseware programs), and inclusion of the article for grant funding purposes.

Gold Open Access Articles: May be shared according to the author-selected end-user license and should contain a [CrossMark logo](#), the end user license, and a DOI link to the formal publication on ScienceDirect.

Please refer to Elsevier's [posting policy](#) for further information.

18. **For book authors** the following clauses are applicable in addition to the above: Authors are permitted to place a brief summary of their work online only. You are not allowed to download and post the published electronic version of your chapter, nor may you scan the printed edition to create an electronic version. **Posting to a repository:** Authors are permitted to post a summary of their chapter only in their institution's repository.

19. **Thesis/Dissertation:** If your license is for use in a thesis/dissertation your thesis may be submitted to your institution in either print or electronic form. Should your thesis be published commercially, please reapply for permission. These requirements include permission for the Library and Archives of Canada to supply single copies, on demand, of the complete thesis and include permission for Proquest/UMI to supply single copies, on demand, of the complete thesis. Should your thesis be published commercially, please reapply for permission. Theses and dissertations which contain embedded PJAs as part of the formal submission can be posted publicly by the awarding institution with DOI links

back to the formal publications on ScienceDirect.

Elsevier Open Access Terms and Conditions

You can publish open access with Elsevier in hundreds of open access journals or in nearly 2000 established subscription journals that support open access publishing. Permitted third party re-use of these open access articles is defined by the author's choice of Creative Commons user license. See our [open access license policy](#) for more information.

Terms & Conditions applicable to all Open Access articles published with Elsevier:

Any reuse of the article must not represent the author as endorsing the adaptation of the article nor should the article be modified in such a way as to damage the author's honour or reputation. If any changes have been made, such changes must be clearly indicated.

The author(s) must be appropriately credited and we ask that you include the end user license and a DOI link to the formal publication on ScienceDirect.

If any part of the material to be used (for example, figures) has appeared in our publication with credit or acknowledgement to another source it is the responsibility of the user to ensure their reuse complies with the terms and conditions determined by the rights holder.

Additional Terms & Conditions applicable to each Creative Commons user license:

CC BY: The CC-BY license allows users to copy, to create extracts, abstracts and new works from the Article, to alter and revise the Article and to make commercial use of the Article (including reuse and/or resale of the Article by commercial entities), provided the user gives appropriate credit (with a link to the formal publication through the relevant DOI), provides a link to the license, indicates if changes were made and the licensor is not represented as endorsing the use made of the work. The full details of the license are available at <http://creativecommons.org/licenses/by/4.0>.

CC BY NC SA: The CC BY-NC-SA license allows users to copy, to create extracts, abstracts and new works from the Article, to alter and revise the Article, provided this is not done for commercial purposes, and that the user gives appropriate credit (with a link to the formal publication through the relevant DOI), provides a link to the license, indicates if changes were made and the licensor is not represented as endorsing the use made of the work. Further, any new works must be made available on the same conditions. The full details of the license are available at <http://creativecommons.org/licenses/by-nc-sa/4.0>.

CC BY NC ND: The CC BY-NC-ND license allows users to copy and distribute the Article, provided this is not done for commercial purposes and further does not permit distribution of the Article if it is changed or edited in any way, and provided the user gives appropriate credit (with a link to the formal publication through the relevant DOI),

provides a link to the license, and that the licensor is not represented as endorsing the use made of the work. The full details of the license are available at <http://creativecommons.org/licenses/by-nc-nd/4.0>. Any commercial reuse of Open Access articles published with a CC BY NC SA or CC BY NC ND license requires permission from Elsevier and will be subject to a fee.

Commercial reuse includes:

- – Associating advertising with the full text of the Article
- – Charging fees for document delivery or access
- – Article aggregation
- – Systematic distribution via e-mail lists or share buttons

Posting or linking by commercial companies for use by customers of those companies.

20. Other Conditions:

Questions? customercare@copyright.com or +1-855-239-3415 (toll free in the US) or +1-978-646-2777.

Gratis licenses (referencing \$0 in the Total field) are free. Please retain this printable license for your reference. No payment is required.

ELSEVIER LICENSE
TERMS AND CONDITIONS

Apr 14, 2015

This is a License Agreement between Victoria Davis ("You") and Elsevier ("Elsevier") provided by Copyright Clearance Center ("CCC"). The license consists of your order details, the terms and conditions provided by Elsevier, and the payment terms and conditions.

All payments must be made in full to CCC. For payment instructions, please see information listed at the bottom of this form.

Supplier	Elsevier Limited The Boulevard, Langford Lane Kidlington, Oxford, OX5 1GB, UK
Registered Company Number	1982084
Customer name	Victoria Davis
Customer address	2000 Simcoe Street North Oshawa, ON L1H 7K4
License number	3607420637696
License date	Apr 13, 2015
Licensed content publisher	Elsevier
Licensed content publication	Materials Science and Engineering: B
Licensed content title	Characterization methods of carbon nanotubes: a review
Licensed content author	T. Belin, F. Epron
Licensed content date	25 May 2005
Licensed content volume number	119
Licensed content issue number	2
Number of pages	14
Start Page	105
End Page	118
Type of Use	reuse in a thesis/dissertation
Intended publisher of new work	other
Portion	figures/tables/illustrations
Number of figures/tables/illustrations	1
Format	both print and electronic
Are you the author of this Elsevier article?	No
Will you be translating?	No
Order reference number	56

Original figure numbers	Fig 1
Title of your thesis/dissertation	Investigation of Dye-Sensitized Solar Cell Performance with Single Chirality Semiconducting Carbon Nanotubes
Expected completion date	Apr 2015
Estimated size (number of pages)	160
Elsevier VAT number	GB 494 6272 12
Permissions price	0.00 USD
VAT/Local Sales Tax	0.00 USD / 0.00 GBP
Total	0.00 USD
Terms and Conditions	

INTRODUCTION

1. The publisher for this copyrighted material is Elsevier. By clicking "accept" in connection with completing this licensing transaction, you agree that the following terms and conditions apply to this transaction (along with the Billing and Payment terms and conditions established by Copyright Clearance Center, Inc. ("CCC"), at the time that you opened your Rightslink account and that are available at any time at <http://myaccount.copyright.com>).

GENERAL TERMS

2. Elsevier hereby grants you permission to reproduce the aforementioned material subject to the terms and conditions indicated.

3. Acknowledgement: If any part of the material to be used (for example, figures) has appeared in our publication with credit or acknowledgement to another source, permission must also be sought from that source. If such permission is not obtained then that material may not be included in your publication/copies. Suitable acknowledgement to the source must be made, either as a footnote or in a reference list at the end of your publication, as follows:

"Reprinted from Publication title, Vol /edition number, Author(s), Title of article / title of chapter, Pages No., Copyright (Year), with permission from Elsevier [OR APPLICABLE SOCIETY COPYRIGHT OWNER]." Also Lancet special credit - "Reprinted from The Lancet, Vol. number, Author(s), Title of article, Pages No., Copyright (Year), with permission from Elsevier."

4. Reproduction of this material is confined to the purpose and/or media for which permission is hereby given.

5. Altering/Modifying Material: Not Permitted. However figures and illustrations may be altered/adapted minimally to serve your work. Any other abbreviations, additions, deletions and/or any other alterations shall be made only with prior written authorization of Elsevier

Ltd. (Please contact Elsevier at permissions@elsevier.com)

6. If the permission fee for the requested use of our material is waived in this instance, please be advised that your future requests for Elsevier materials may attract a fee.

7. **Reservation of Rights:** Publisher reserves all rights not specifically granted in the combination of (i) the license details provided by you and accepted in the course of this licensing transaction, (ii) these terms and conditions and (iii) CCC's Billing and Payment terms and conditions.

8. **License Contingent Upon Payment:** While you may exercise the rights licensed immediately upon issuance of the license at the end of the licensing process for the transaction, provided that you have disclosed complete and accurate details of your proposed use, no license is finally effective unless and until full payment is received from you (either by publisher or by CCC) as provided in CCC's Billing and Payment terms and conditions. If full payment is not received on a timely basis, then any license preliminarily granted shall be deemed automatically revoked and shall be void as if never granted. Further, in the event that you breach any of these terms and conditions or any of CCC's Billing and Payment terms and conditions, the license is automatically revoked and shall be void as if never granted. Use of materials as described in a revoked license, as well as any use of the materials beyond the scope of an unrevoked license, may constitute copyright infringement and publisher reserves the right to take any and all action to protect its copyright in the materials.

9. **Warranties:** Publisher makes no representations or warranties with respect to the licensed material.

10. **Indemnity:** You hereby indemnify and agree to hold harmless publisher and CCC, and their respective officers, directors, employees and agents, from and against any and all claims arising out of your use of the licensed material other than as specifically authorized pursuant to this license.

11. **No Transfer of License:** This license is personal to you and may not be sublicensed, assigned, or transferred by you to any other person without publisher's written permission.

12. **No Amendment Except in Writing:** This license may not be amended except in a writing signed by both parties (or, in the case of publisher, by CCC on publisher's behalf).

13. **Objection to Contrary Terms:** Publisher hereby objects to any terms contained in any purchase order, acknowledgment, check endorsement or other writing prepared by you, which terms are inconsistent with these terms and conditions or CCC's Billing and Payment terms and conditions. These terms and conditions, together with CCC's Billing and Payment terms and conditions (which are incorporated herein), comprise the entire agreement between you and publisher (and CCC) concerning this licensing transaction. In the event of any conflict between your obligations established by these terms and conditions and those established by CCC's Billing and Payment terms and conditions, these

terms and conditions shall control.

14. **Revocation:** Elsevier or Copyright Clearance Center may deny the permissions described in this License at their sole discretion, for any reason or no reason, with a full refund payable to you. Notice of such denial will be made using the contact information provided by you. Failure to receive such notice will not alter or invalidate the denial. In no event will Elsevier or Copyright Clearance Center be responsible or liable for any costs, expenses or damage incurred by you as a result of a denial of your permission request, other than a refund of the amount(s) paid by you to Elsevier and/or Copyright Clearance Center for denied permissions.

LIMITED LICENSE

The following terms and conditions apply only to specific license types:

15. **Translation:** This permission is granted for non-exclusive world **English** rights only unless your license was granted for translation rights. If you licensed translation rights you may only translate this content into the languages you requested. A professional translator must perform all translations and reproduce the content word for word preserving the integrity of the article. If this license is to re-use 1 or 2 figures then permission is granted for non-exclusive world rights in all languages.

16. **Posting licensed content on any Website:** The following terms and conditions apply as follows: Licensing material from an Elsevier journal: All content posted to the web site must maintain the copyright information line on the bottom of each image; A hyper-text must be included to the Homepage of the journal from which you are licensing at <http://www.sciencedirect.com/science/journal/xxxxx> or the Elsevier homepage for books at <http://www.elsevier.com>; Central Storage: This license does not include permission for a scanned version of the material to be stored in a central repository such as that provided by Heron/XanEdu.

Licensing material from an Elsevier book: A hyper-text link must be included to the Elsevier homepage at <http://www.elsevier.com> . All content posted to the web site must maintain the copyright information line on the bottom of each image.

Posting licensed content on Electronic reserve: In addition to the above the following clauses are applicable: The web site must be password-protected and made available only to bona fide students registered on a relevant course. This permission is granted for 1 year only. You may obtain a new license for future website posting.

17. **For journal authors:** the following clauses are applicable in addition to the above:

Preprints:

A preprint is an author's own write-up of research results and analysis, it has not been peer-

reviewed, nor has it had any other value added to it by a publisher (such as formatting, copyright, technical enhancement etc.).

Authors can share their preprints anywhere at any time. Preprints should not be added to or enhanced in any way in order to appear more like, or to substitute for, the final versions of articles however authors can update their preprints on arXiv or RePEc with their Accepted Author Manuscript (see below).

If accepted for publication, we encourage authors to link from the preprint to their formal publication via its DOI. Millions of researchers have access to the formal publications on ScienceDirect, and so links will help users to find, access, cite and use the best available version. Please note that Cell Press, The Lancet and some society-owned have different preprint policies. Information on these policies is available on the journal homepage.

Accepted Author Manuscripts: An accepted author manuscript is the manuscript of an article that has been accepted for publication and which typically includes author-incorporated changes suggested during submission, peer review and editor-author communications.

Authors can share their accepted author manuscript:

- – immediately
 - via their non-commercial person homepage or blog
 - by updating a preprint in arXiv or RePEc with the accepted manuscript
 - via their research institute or institutional repository for internal institutional uses or as part of an invitation-only research collaboration work-group
 - directly by providing copies to their students or to research collaborators for their personal use
 - for private scholarly sharing as part of an invitation-only work group on commercial sites with which Elsevier has an agreement
- – after the embargo period
 - via non-commercial hosting platforms such as their institutional repository
 - via commercial sites with which Elsevier has an agreement

In all cases accepted manuscripts should:

- – link to the formal publication via its DOI
- – bear a CC-BY-NC-ND license - this is easy to do
- – if aggregated with other manuscripts, for example in a repository or other site, be shared in alignment with our hosting policy not be added to or enhanced in any way to appear more like, or to substitute for, the published journal article.

Published journal article (JPA): A published journal article (PJA) is the definitive final

record of published research that appears or will appear in the journal and embodies all value-adding publishing activities including peer review co-ordination, copy-editing, formatting, (if relevant) pagination and online enrichment.

Policies for sharing publishing journal articles differ for subscription and gold open access articles:

Subscription Articles: If you are an author, please share a link to your article rather than the full-text. Millions of researchers have access to the formal publications on ScienceDirect, and so links will help your users to find, access, cite, and use the best available version.

Theses and dissertations which contain embedded PJAs as part of the formal submission can be posted publicly by the awarding institution with DOI links back to the formal publications on ScienceDirect.

If you are affiliated with a library that subscribes to ScienceDirect you have additional private sharing rights for others' research accessed under that agreement. This includes use for classroom teaching and internal training at the institution (including use in course packs and courseware programs), and inclusion of the article for grant funding purposes.

Gold Open Access Articles: May be shared according to the author-selected end-user license and should contain a [CrossMark logo](#), the end user license, and a DOI link to the formal publication on ScienceDirect.

Please refer to Elsevier's [posting policy](#) for further information.

18. **For book authors** the following clauses are applicable in addition to the above: Authors are permitted to place a brief summary of their work online only. You are not allowed to download and post the published electronic version of your chapter, nor may you scan the printed edition to create an electronic version. **Posting to a repository:** Authors are permitted to post a summary of their chapter only in their institution's repository.

19. **Thesis/Dissertation:** If your license is for use in a thesis/dissertation your thesis may be submitted to your institution in either print or electronic form. Should your thesis be published commercially, please reapply for permission. These requirements include permission for the Library and Archives of Canada to supply single copies, on demand, of the complete thesis and include permission for Proquest/UMI to supply single copies, on demand, of the complete thesis. Should your thesis be published commercially, please reapply for permission. Theses and dissertations which contain embedded PJAs as part of the formal submission can be posted publicly by the awarding institution with DOI links back to the formal publications on ScienceDirect.

Elsevier Open Access Terms and Conditions

You can publish open access with Elsevier in hundreds of open access journals or in nearly 2000 established subscription journals that support open access publishing. Permitted third party re-use of these open access articles is defined by the author's choice of Creative Commons user license. See our [open access license policy](#) for more information.

Terms & Conditions applicable to all Open Access articles published with Elsevier:

Any reuse of the article must not represent the author as endorsing the adaptation of the article nor should the article be modified in such a way as to damage the author's honour or reputation. If any changes have been made, such changes must be clearly indicated.

The author(s) must be appropriately credited and we ask that you include the end user license and a DOI link to the formal publication on ScienceDirect.

If any part of the material to be used (for example, figures) has appeared in our publication with credit or acknowledgement to another source it is the responsibility of the user to ensure their reuse complies with the terms and conditions determined by the rights holder.

Additional Terms & Conditions applicable to each Creative Commons user license:

CC BY: The CC-BY license allows users to copy, to create extracts, abstracts and new works from the Article, to alter and revise the Article and to make commercial use of the Article (including reuse and/or resale of the Article by commercial entities), provided the user gives appropriate credit (with a link to the formal publication through the relevant DOI), provides a link to the license, indicates if changes were made and the licensor is not represented as endorsing the use made of the work. The full details of the license are available at <http://creativecommons.org/licenses/by/4.0>.

CC BY NC SA: The CC BY-NC-SA license allows users to copy, to create extracts, abstracts and new works from the Article, to alter and revise the Article, provided this is not done for commercial purposes, and that the user gives appropriate credit (with a link to the formal publication through the relevant DOI), provides a link to the license, indicates if changes were made and the licensor is not represented as endorsing the use made of the work. Further, any new works must be made available on the same conditions. The full details of the license are available at <http://creativecommons.org/licenses/by-nc-sa/4.0>.

CC BY NC ND: The CC BY-NC-ND license allows users to copy and distribute the Article, provided this is not done for commercial purposes and further does not permit distribution of the Article if it is changed or edited in any way, and provided the user gives appropriate credit (with a link to the formal publication through the relevant DOI), provides a link to the license, and that the licensor is not represented as endorsing the use made of the work. The full details of the license are available at <http://creativecommons.org/licenses/by-nc-nd/4.0>. Any commercial reuse of Open Access articles published with a CC BY NC SA or CC BY NC ND license requires permission

from Elsevier and will be subject to a fee.

Commercial reuse includes:

- – Associating advertising with the full text of the Article
- – Charging fees for document delivery or access
- – Article aggregation
- – Systematic distribution via e-mail lists or share buttons

Posting or linking by commercial companies for use by customers of those companies.

20. Other Conditions:

Questions? customer care@copyright.com or +1-855-239-3415 (toll free in the US) or +1-978-646-2777.

Gratis licenses (referencing \$0 in the Total field) are free. Please retain this printable license for your reference. No payment is required.

JOHN WILEY AND SONS LICENSE
TERMS AND CONDITIONS

Apr 14, 2015

This Agreement between Victoria Davis ("You") and John Wiley and Sons ("John Wiley and Sons") consists of your license details and the terms and conditions provided by John Wiley and Sons and Copyright Clearance Center.

License Number	3607420920908
License date	Apr 13, 2015
Licensed Content Publisher	John Wiley and Sons
Licensed Content Publication	Angewandte Chemie International Edition
Licensed Content Title	Functionalization of Single-Walled Carbon Nanotubes
Licensed Content Author	Andreas Hirsch
Licensed Content Date	May 28, 2002
Pages	7
Type of use	Dissertation/Thesis
Requestor type	University/Academic
Format	Print and electronic
Portion	Figure/table
Number of figures/tables	1
Original Wiley figure/table number(s)	Figure 5
Will you be translating?	No
Order reference number	62
Title of your thesis / dissertation	Investigation of Dye-Sensitized Solar Cell Performance with Single Chirality Semiconducting Carbon Nanotubes
Expected completion date	Apr 2015
Expected size (number of pages)	160
Requestor Location	Victoria Davis 2000 Simcoe Street North
Billing Type	Oshawa, ON L1H 7K4 Canada Attn: Victoria Davis
Billing Address	Invoice Victoria Davis 2000 Simcoe Street North

Oshawa, ON L1H 7K4

Canada

Attn: Victoria Davis

Total

0.00 USD

Terms and Conditions

TERMS AND CONDITIONS

This copyrighted material is owned by or exclusively licensed to John Wiley & Sons, Inc. or one of its group companies (each a "Wiley Company") or handled on behalf of a society with which a Wiley Company has exclusive publishing rights in relation to a particular work (collectively "WILEY"). By clicking  in connection with completing this licensing transaction, you agree that the following terms and conditions apply to this transaction (along with the billing and payment terms and conditions established by the Copyright Clearance Center Inc., ("CCC's Billing and Payment terms and conditions"), at the time that you opened your Rightslink account (these are available at any time at <http://myaccount.copyright.com>).

Terms and Conditions

- The materials you have requested permission to reproduce or reuse (the "Wiley Materials") are protected by copyright.
- You are hereby granted a personal, non-exclusive, non-sub licensable (on a stand-alone basis), non-transferable, worldwide, limited license to reproduce the Wiley Materials for the purpose specified in the licensing process. This license is for a one-time use only and limited to any maximum distribution number specified in the license. The first instance of republication or reuse granted by this licence must be completed within two years of the date of the grant of this licence (although copies prepared before the end date may be distributed thereafter). The Wiley Materials shall not be used in any other manner or for any other purpose, beyond what is granted in the license. Permission is granted subject to an appropriate acknowledgement given to the author, title of the material/book/journal and the publisher. You shall also duplicate the copyright notice that appears in the Wiley publication in your use of the Wiley Material. Permission is also granted on the understanding that nowhere in the text is a previously published source acknowledged for all or part of this Wiley Material. Any third party content is expressly excluded from this permission.
- With respect to the Wiley Materials, all rights are reserved. Except as expressly granted by the terms of the license, no part of the Wiley Materials may be copied, modified, adapted (except for minor reformatting required by the new Publication), translated, reproduced, transferred or distributed, in any form or by any means, and no derivative works may be made based on the Wiley Materials without the prior

permission of the respective copyright owner. You may not alter, remove or suppress in any manner any copyright, trademark or other notices displayed by the Wiley Materials. You may not license, rent, sell, loan, lease, pledge, offer as security, transfer or assign the Wiley Materials on a stand-alone basis, or any of the rights granted to you hereunder to any other person.

- The Wiley Materials and all of the intellectual property rights therein shall at all times remain the exclusive property of John Wiley & Sons Inc, the Wiley Companies, or their respective licensors, and your interest therein is only that of having possession of and the right to reproduce the Wiley Materials pursuant to Section 2 herein during the continuance of this Agreement. You agree that you own no right, title or interest in or to the Wiley Materials or any of the intellectual property rights therein. You shall have no rights hereunder other than the license as provided for above in Section 2. No right, license or interest to any trademark, trade name, service mark or other branding ("Marks") of WILEY or its licensors is granted hereunder, and you agree that you shall not assert any such right, license or interest with respect thereto.
- NEITHER WILEY NOR ITS LICENSORS MAKES ANY WARRANTY OR REPRESENTATION OF ANY KIND TO YOU OR ANY THIRD PARTY, EXPRESS, IMPLIED OR STATUTORY, WITH RESPECT TO THE MATERIALS OR THE ACCURACY OF ANY INFORMATION CONTAINED IN THE MATERIALS, INCLUDING, WITHOUT LIMITATION, ANY IMPLIED WARRANTY OF MERCHANTABILITY, ACCURACY, SATISFACTORY QUALITY, FITNESS FOR A PARTICULAR PURPOSE, USABILITY, INTEGRATION OR NON-INFRINGEMENT AND ALL SUCH WARRANTIES ARE HEREBY EXCLUDED BY WILEY AND ITS LICENSORS AND WAIVED BY YOU
- WILEY shall have the right to terminate this Agreement immediately upon breach of this Agreement by you.
- You shall indemnify, defend and hold harmless WILEY, its Licensors and their respective directors, officers, agents and employees, from and against any actual or threatened claims, demands, causes of action or proceedings arising from any breach of this Agreement by you.
- IN NO EVENT SHALL WILEY OR ITS LICENSORS BE LIABLE TO YOU OR ANY OTHER PARTY OR ANY OTHER PERSON OR ENTITY FOR ANY SPECIAL, CONSEQUENTIAL, INCIDENTAL, INDIRECT, EXEMPLARY OR PUNITIVE DAMAGES, HOWEVER CAUSED, ARISING OUT OF OR IN CONNECTION WITH THE DOWNLOADING, PROVISIONING, VIEWING OR USE OF THE MATERIALS REGARDLESS OF THE FORM OF ACTION, WHETHER FOR BREACH OF CONTRACT, BREACH OF WARRANTY, TORT, NEGLIGENCE, INFRINGEMENT OR OTHERWISE (INCLUDING, WITHOUT LIMITATION, DAMAGES BASED ON LOSS OF PROFITS, DATA, FILES, USE, BUSINESS OPPORTUNITY OR CLAIMS OF THIRD PARTIES), AND WHETHER OR NOT THE PARTY HAS BEEN ADVISED OF THE

POSSIBILITY OF SUCH DAMAGES. THIS LIMITATION SHALL APPLY NOTWITHSTANDING ANY FAILURE OF ESSENTIAL PURPOSE OF ANY LIMITED REMEDY PROVIDED HEREIN.

- Should any provision of this Agreement be held by a court of competent jurisdiction to be illegal, invalid, or unenforceable, that provision shall be deemed amended to achieve as nearly as possible the same economic effect as the original provision, and the legality, validity and enforceability of the remaining provisions of this Agreement shall not be affected or impaired thereby.
- The failure of either party to enforce any term or condition of this Agreement shall not constitute a waiver of either party's right to enforce each and every term and condition of this Agreement. No breach under this agreement shall be deemed waived or excused by either party unless such waiver or consent is in writing signed by the party granting such waiver or consent. The waiver by or consent of a party to a breach of any provision of this Agreement shall not operate or be construed as a waiver of or consent to any other or subsequent breach by such other party.
- This Agreement may not be assigned (including by operation of law or otherwise) by you without WILEY's prior written consent.
- Any fee required for this permission shall be non-refundable after thirty (30) days from receipt by the CCC.
- These terms and conditions together with CCC's Billing and Payment terms and conditions (which are incorporated herein) form the entire agreement between you and WILEY concerning this licensing transaction and (in the absence of fraud) supersedes all prior agreements and representations of the parties, oral or written. This Agreement may not be amended except in writing signed by both parties. This Agreement shall be binding upon and inure to the benefit of the parties' successors, legal representatives, and authorized assigns.
- In the event of any conflict between your obligations established by these terms and conditions and those established by CCC's Billing and Payment terms and conditions, these terms and conditions shall prevail.
- WILEY expressly reserves all rights not specifically granted in the combination of (i) the license details provided by you and accepted in the course of this licensing transaction, (ii) these terms and conditions and (iii) CCC's Billing and Payment terms and conditions.
- This Agreement will be void if the Type of Use, Format, Circulation, or Requestor Type was misrepresented during the licensing process.
- This Agreement shall be governed by and construed in accordance with the laws of the State of New York, USA, without regards to such state's conflict of law rules. Any legal action, suit or proceeding arising out of or relating to these Terms and

Conditions or the breach thereof shall be instituted in a court of competent jurisdiction in New York County in the State of New York in the United States of America and each party hereby consents and submits to the personal jurisdiction of such court, waives any objection to venue in such court and consents to service of process by registered or certified mail, return receipt requested, at the last known address of such party.

WILEY OPEN ACCESS TERMS AND CONDITIONS

Wiley Publishes Open Access Articles in fully Open Access Journals and in Subscription journals offering Online Open. Although most of the fully Open Access journals publish open access articles under the terms of the Creative Commons Attribution (CC BY) License only, the subscription journals and a few of the Open Access Journals offer a choice of Creative Commons Licenses:: Creative Commons Attribution (CC-BY) license [Creative Commons Attribution Non-Commercial \(CC-BY-NC\) license](#) and [Creative Commons Attribution Non-Commercial-NoDerivs \(CC-BY-NC-ND\) License](#). The license type is clearly identified on the article.

Copyright in any research article in a journal published as Open Access under a Creative Commons License is retained by the author(s). Authors grant Wiley a license to publish the article and identify itself as the original publisher. Authors also grant any third party the right to use the article freely as long as its integrity is maintained and its original authors, citation details and publisher are identified as follows: [Title of Article/Author/Journal Title and Volume/Issue. Copyright (c) [year] [copyright owner as specified in the Journal]. Links to the final article on Wiley's website are encouraged where applicable.

The Creative Commons Attribution License

The [Creative Commons Attribution License \(CC-BY\)](#) allows users to copy, distribute and transmit an article, adapt the article and make commercial use of the article. The CC-BY license permits commercial and non-commercial re-use of an open access article, as long as the author is properly attributed.

The Creative Commons Attribution License does not affect the moral rights of authors, including without limitation the right not to have their work subjected to derogatory treatment. It also does not affect any other rights held by authors or third parties in the article, including without limitation the rights of privacy and publicity. Use of the article must not assert or imply, whether implicitly or explicitly, any connection with, endorsement or sponsorship of such use by the author, publisher or any other party associated with the article.

For any reuse or distribution, users must include the copyright notice and make clear to others that the article is made available under a Creative Commons Attribution license, linking to the relevant Creative Commons web page.

To the fullest extent permitted by applicable law, the article is made available as is and

without representation or warranties of any kind whether express, implied, statutory or otherwise and including, without limitation, warranties of title, merchantability, fitness for a particular purpose, non-infringement, absence of defects, accuracy, or the presence or absence of errors.

Creative Commons Attribution Non-Commercial License

The [Creative Commons Attribution Non-Commercial \(CC-BY-NC\) License](#) permits use, distribution and reproduction in any medium, provided the original work is properly cited and is not used for commercial purposes.(see below)

Creative Commons Attribution-Non-Commercial-NoDerivs License

The [Creative Commons Attribution Non-Commercial-NoDerivs License](#) (CC-BY-NC-ND) permits use, distribution and reproduction in any medium, provided the original work is properly cited, is not used for commercial purposes and no modifications or adaptations are made. (see below)

Use by non-commercial users

For non-commercial and non-promotional purposes, individual users may access, download, copy, display and redistribute to colleagues Wiley Open Access articles, as well as adapt, translate, text- and data-mine the content subject to the following conditions:

- The authors' moral rights are not compromised. These rights include the right of "paternity" (also known as "attribution" - the right for the author to be identified as such) and "integrity" (the right for the author not to have the work altered in such a way that the author's reputation or integrity may be impugned).
- Where content in the article is identified as belonging to a third party, it is the obligation of the user to ensure that any reuse complies with the copyright policies of the owner of that content.
- If article content is copied, downloaded or otherwise reused for non-commercial research and education purposes, a link to the appropriate bibliographic citation (authors, journal, article title, volume, issue, page numbers, DOI and the link to the definitive published version on **Wiley Online Library**) should be maintained. Copyright notices and disclaimers must not be deleted.
- Any translations, for which a prior translation agreement with Wiley has not been agreed, must prominently display the statement: "This is an unofficial translation of an article that appeared in a Wiley publication. The publisher has not endorsed this translation."

Use by commercial "for-profit" organisations

Use of Wiley Open Access articles for commercial, promotional, or marketing purposes

requires further explicit permission from Wiley and will be subject to a fee. Commercial purposes include:

- Copying or downloading of articles, or linking to such articles for further redistribution, sale or licensing;
- Copying, downloading or posting by a site or service that incorporates advertising with such content;
- The inclusion or incorporation of article content in other works or services (other than normal quotations with an appropriate citation) that is then available for sale or licensing, for a fee (for example, a compilation produced for marketing purposes, inclusion in a sales pack)
- Use of article content (other than normal quotations with appropriate citation) by for-profit organisations for promotional purposes
- Linking to article content in e-mails redistributed for promotional, marketing or educational purposes;
- Use for the purposes of monetary reward by means of sale, resale, licence, loan, transfer or other form of commercial exploitation such as marketing products
- Print reprints of Wiley Open Access articles can be purchased from:
corporatesales@wiley.com

Further details can be found on Wiley Online Library
<http://olabout.wiley.com/WileyCDA/Section/id-410895.html>

Other Terms and Conditions:

v1.9

Questions? customercare@copyright.com or +1-855-239-3415 (toll free in the US) or +1-978-646-2777.

Gratis licenses (referencing \$0 in the Total field) are free. Please retain this printable license for your reference. No payment is required.

NATURE PUBLISHING GROUP LICENSE
TERMS AND CONDITIONS

Apr 14, 2015

This is a License Agreement between Victoria Davis ("You") and Nature Publishing Group ("Nature Publishing Group") provided by Copyright Clearance Center ("CCC"). The license consists of your order details, the terms and conditions provided by Nature Publishing Group, and the payment terms and conditions.

All payments must be made in full to CCC. For payment instructions, please see information listed at the bottom of this form.

License Number	3607430019222
License date	Apr 14, 2015
Licensed content publisher	Nature Publishing Group
Licensed content publication	Nature Nanotechnology
Licensed content title	Sorting carbon nanotubes by electronic structure using density differentiation
Licensed content author	Michael S. Arnold, Alexander A. Green, James F. Hulvat, Samuel I. Stupp and Mark C. Hersam
Licensed content date	Oct 4, 2006
Volume number	1
Issue number	1
Type of Use	reuse in a dissertation / thesis
Requestor type	academic/educational
Format	print and electronic
Portion	figures/tables/illustrations
Number of figures/tables/illustrations	1
High-res required	no
Figures	Figure 1 b
Author of this NPG article	no
Your reference number	95
Title of your thesis / dissertation	Investigation of Dye-Sensitized Solar Cell Performance with Single Chirality Semiconducting Carbon Nanotubes
Expected completion date	Apr 2015
Estimated size (number of pages)	160
Total	0.00 USD
Terms and Conditions	

Terms and Conditions for Permissions

Nature Publishing Group hereby grants you a non-exclusive license to reproduce this material for this purpose, and for no other use, subject to the conditions below:

1. NPG warrants that it has, to the best of its knowledge, the rights to license reuse of this material. However, you should ensure that the material you are requesting is original to Nature Publishing Group and does not carry the copyright of another entity (as credited in the published version). If the credit line on any part of the material you have requested indicates that it was reprinted or adapted by NPG with permission from another source, then you should also seek permission from that source to reuse the material.
2. Permission granted free of charge for material in print is also usually granted for any electronic version of that work, provided that the material is incidental to the work as a whole and that the electronic version is essentially equivalent to, or substitutes for, the print version. Where print permission has been granted for a fee, separate permission must be obtained for any additional, electronic re-use (unless, as in the case of a full paper, this has already been accounted for during your initial request in the calculation of a print run). NB: In all cases, web-based use of full-text articles must be authorized separately through the 'Use on a Web Site' option when requesting permission.
3. Permission granted for a first edition does not apply to second and subsequent editions and for editions in other languages (except for signatories to the STM Permissions Guidelines, or where the first edition permission was granted for free).
4. Nature Publishing Group's permission must be acknowledged next to the figure, table or abstract in print. In electronic form, this acknowledgement must be visible at the same time as the figure/table/abstract, and must be hyperlinked to the journal's homepage.
5. The credit line should read:
Reprinted by permission from Macmillan Publishers Ltd: [JOURNAL NAME]
(reference citation), copyright (year of publication)
For AOP papers, the credit line should read:
Reprinted by permission from Macmillan Publishers Ltd: [JOURNAL NAME],
advance online publication, day month year (doi: 10.1038/sj.[JOURNAL
ACRONYM].XXXXX)

Note: For republication from the *British Journal of Cancer*, the following credit lines apply.

Reprinted by permission from Macmillan Publishers Ltd on behalf of Cancer Research UK: [JOURNAL NAME] (reference citation), copyright (year of

publication)For AOP papers, the credit line should read:
Reprinted by permission from Macmillan Publishers Ltd on behalf of Cancer
Research UK: [JOURNAL NAME], advance online publication, day month year
(doi: 10.1038/sj.[JOURNAL ACRONYM].XXXXX)

6. Adaptations of single figures do not require NPG approval. However, the adaptation should be credited as follows:

Adapted by permission from Macmillan Publishers Ltd: [JOURNAL NAME]
(reference citation), copyright (year of publication)

Note: For adaptation from the *British Journal of Cancer*, the following credit line applies.

Adapted by permission from Macmillan Publishers Ltd on behalf of Cancer
Research UK: [JOURNAL NAME] (reference citation), copyright (year of
publication)

7. Translations of 401 words up to a whole article require NPG approval. Please visit <http://www.macmillanmedicalcommunications.com> for more information. Translations of up to a 400 words do not require NPG approval. The translation should be credited as follows:

Translated by permission from Macmillan Publishers Ltd: [JOURNAL NAME]
(reference citation), copyright (year of publication).

Note: For translation from the *British Journal of Cancer*, the following credit line applies.

Translated by permission from Macmillan Publishers Ltd on behalf of Cancer
Research UK: [JOURNAL NAME] (reference citation), copyright (year of
publication)

We are certain that all parties will benefit from this agreement and wish you the best in the use of this material. Thank you.

Special Terms:

v1.1

Questions? customercare@copyright.com or +1-855-239-3415 (toll free in the US) or +1-978-646-2777.

Gratis licenses (referencing \$0 in the Total field) are free. Please retain this printable license for your reference. No payment is required.

THE AMERICAN ASSOCIATION FOR THE ADVANCEMENT OF SCIENCE
LICENSE
TERMS AND CONDITIONS
Apr 14, 2015

This is a License Agreement between Victoria Davis ("You") and The American Association for the Advancement of Science ("The American Association for the Advancement of Science") provided by Copyright Clearance Center ("CCC"). The license consists of your order details, the terms and conditions provided by The American Association for the Advancement of Science, and the payment terms and conditions.

All payments must be made in full to CCC. For payment instructions, please see information listed at the bottom of this form.

License Number	3607430367222
License date	Apr 14, 2015
Licensed content publisher	The American Association for the Advancement of Science
Licensed content publication	Science
Licensed content title	Separation of Metallic from Semiconducting Single-Walled Carbon Nanotubes
Licensed content author	Ralph Krupke, Frank Hennrich, Hilbert v. Löhneysen, Manfred M. Kappes
Licensed content date	Jul 18, 2003
Volume number	301
Issue number	5631
Type of Use	Thesis / Dissertation
Requestor type	Scientist/individual at a research institution
Format	Print and electronic
Portion	Figure
Number of figures/tables	1
Order reference number	101
Title of your thesis / dissertation	Investigation of Dye-Sensitized Solar Cell Performance with Single Chirality Semiconducting Carbon Nanotubes
Expected completion date	Apr 2015
Estimated size(pages)	160
Total	0.00 USD
Terms and Conditions	

American Association for the Advancement of Science TERMS AND CONDITIONS

Regarding your request, we are pleased to grant you non-exclusive, non-transferable permission, to republish the AAAS material identified above in your work identified above,

subject to the terms and conditions herein. We must be contacted for permission for any uses other than those specifically identified in your request above.

The following credit line must be printed along with the AAAS material: "From [Full Reference Citation]. Reprinted with permission from AAAS."

All required credit lines and notices must be visible any time a user accesses any part of the AAAS material and must appear on any printed copies and authorized user might make.

This permission does not apply to figures / photos / artwork or any other content or materials included in your work that are credited to non-AAAS sources. If the requested material is sourced to or references non-AAAS sources, you must obtain authorization from that source as well before using that material. You agree to hold harmless and indemnify AAAS against any claims arising from your use of any content in your work that is credited to non-AAAS sources.

If the AAAS material covered by this permission was published in Science during the years 1974 - 1994, you must also obtain permission from the author, who may grant or withhold permission, and who may or may not charge a fee if permission is granted. See original article for author's address. This condition does not apply to news articles.

The AAAS material may not be modified or altered except that figures and tables may be modified with permission from the author. Author permission for any such changes must be secured prior to your use.

Whenever possible, we ask that electronic uses of the AAAS material permitted herein include a hyperlink to the original work on AAAS's website (hyperlink may be embedded in the reference citation).

AAAS material reproduced in your work identified herein must not account for more than 30% of the total contents of that work.

AAAS must publish the full paper prior to use of any text.

AAAS material must not imply any endorsement by the American Association for the Advancement of Science.

This permission is not valid for the use of the AAAS and/or Science logos.

AAAS makes no representations or warranties as to the accuracy of any information contained in the AAAS material covered by this permission, including any warranties of merchantability or fitness for a particular purpose.

If permission fees for this use are waived, please note that AAAS reserves the right to

charge for reproduction of this material in the future.

Permission is not valid unless payment is received within sixty (60) days of the issuance of this permission. If payment is not received within this time period then all rights granted herein shall be revoked and this permission will be considered null and void.

In the event of breach of any of the terms and conditions herein or any of CCC's Billing and Payment terms and conditions, all rights granted herein shall be revoked and this permission will be considered null and void.

AAAS reserves the right to terminate this permission and all rights granted herein at its discretion, for any purpose, at any time. In the event that AAAS elects to terminate this permission, you will have no further right to publish, publicly perform, publicly display, distribute or otherwise use any matter in which the AAAS content had been included, and all fees paid hereunder shall be fully refunded to you. Notification of termination will be sent to the contact information as supplied by you during the request process and termination shall be immediate upon sending the notice. Neither AAAS nor CCC shall be liable for any costs, expenses, or damages you may incur as a result of the termination of this permission, beyond the refund noted above.

This Permission may not be amended except by written document signed by both parties.

The terms above are applicable to all permissions granted for the use of AAAS material. Below you will find additional conditions that apply to your particular type of use.

FOR A THESIS OR DISSERTATION

If you are using figure(s)/table(s), permission is granted for use in print and electronic versions of your dissertation or thesis. A full text article may be used in print versions only of a dissertation or thesis.

Permission covers the distribution of your dissertation or thesis on demand by ProQuest / UMI, provided the AAAS material covered by this permission remains in situ.

If you are an Original Author on the AAAS article being reproduced, please refer to your License to Publish for rules on reproducing your paper in a dissertation or thesis.

FOR JOURNALS:

Permission covers both print and electronic versions of your journal article, however the AAAS material may not be used in any manner other than within the context of your article.

FOR BOOKS/TEXTBOOKS:

If this license is to reuse figures/tables, then permission is granted for non-exclusive world rights in all languages in both print and electronic formats (electronic formats are defined below).

If this license is to reuse a text excerpt or a full text article, then permission is granted for

non-exclusive world rights in English only. You have the option of securing either print or electronic rights or both, but electronic rights are not automatically granted and do garner additional fees. Permission for translations of text excerpts or full text articles into other languages must be obtained separately.

Licenses granted for use of AAAS material in electronic format books/textbooks are valid only in cases where the electronic version is equivalent to or substitutes for the print version of the book/textbook. The AAAS material reproduced as permitted herein must remain in situ and must not be exploited separately (for example, if permission covers the use of a full text article, the article may not be offered for access or for purchase as a stand-alone unit), except in the case of permitted textbook companions as noted below.

You must include the following notice in any electronic versions, either adjacent to the reprinted AAAS material or in the terms and conditions for use of your electronic products: "Readers may view, browse, and/or download material for temporary copying purposes only, provided these uses are for noncommercial personal purposes. Except as provided by law, this material may not be further reproduced, distributed, transmitted, modified, adapted, performed, displayed, published, or sold in whole or in part, without prior written permission from the publisher."

If your book is an academic textbook, permission covers the following companions to your textbook, provided such companions are distributed only in conjunction with your textbook at no additional cost to the user:

- Password-protected website
- Instructor's image CD/DVD and/or PowerPoint resource
- Student CD/DVD

All companions must contain instructions to users that the AAAS material may be used for non-commercial, classroom purposes only. Any other uses require the prior written permission from AAAS.

If your license is for the use of AAAS Figures/Tables, then the electronic rights granted herein permit use of the Licensed Material in any Custom Databases that you distribute the electronic versions of your textbook through, so long as the Licensed Material remains within the context of a chapter of the title identified in your request and cannot be downloaded by a user as an independent image file.

Rights also extend to copies/files of your Work (as described above) that you are required to provide for use by the visually and/or print disabled in compliance with state and federal laws.

This permission only covers a single edition of your work as identified in your request.

FOR NEWSLETTERS:

Permission covers print and/or electronic versions, provided the AAAS material reproduced as permitted herein remains in situ and is not exploited separately (for example, if permission covers the use of a full text article, the article may not be offered for access or for purchase as a stand-alone unit)

FOR ANNUAL REPORTS:

Permission covers print and electronic versions provided the AAAS material reproduced as permitted herein remains in situ and is not exploited separately (for example, if permission covers the use of a full text article, the article may not be offered for access or for purchase as a stand-alone unit)

FOR PROMOTIONAL/MARKETING USES:

Permission covers the use of AAAS material in promotional or marketing pieces such as information packets, media kits, product slide kits, brochures, or flyers limited to a single print run. The AAAS Material may not be used in any manner which implies endorsement or promotion by the American Association for the Advancement of Science (AAAS) or Science of any product or service. AAAS does not permit the reproduction of its name, logo or text on promotional literature.

If permission to use a full text article is permitted, The Science article covered by this permission must not be altered in any way. No additional printing may be set onto an article copy other than the copyright credit line required above. Any alterations must be approved in advance and in writing by AAAS. This includes, but is not limited to, the placement of sponsorship identifiers, trademarks, logos, rubber stamping or self-adhesive stickers onto the article copies.

Additionally, article copies must be a freestanding part of any information package (i.e. media kit) into which they are inserted. They may not be physically attached to anything, such as an advertising insert, or have anything attached to them, such as a sample product. Article copies must be easily removable from any kits or informational packages in which they are used. The only exception is that article copies may be inserted into three-ring binders.

FOR CORPORATE INTERNAL USE:

The AAAS material covered by this permission may not be altered in any way. No additional printing may be set onto an article copy other than the required credit line. Any alterations must be approved in advance and in writing by AAAS. This includes, but is not limited to the placement of sponsorship identifiers, trademarks, logos, rubber stamping or self-adhesive stickers onto article copies.

If you are making article copies, copies are restricted to the number indicated in your request and must be distributed only to internal employees for internal use.

If you are using AAAS Material in Presentation Slides, the required credit line must be visible on the slide where the AAAS material will be reprinted

If you are using AAAS Material on a CD, DVD, Flash Drive, or the World Wide Web, you must include the following notice in any electronic versions, either adjacent to the reprinted AAAS material or in the terms and conditions for use of your electronic products: "Readers may view, browse, and/or download material for temporary copying purposes only, provided these uses are for noncommercial personal purposes. Except as provided by law, this material may not be further reproduced, distributed, transmitted, modified, adapted, performed, displayed, published, or sold in whole or in part, without prior written permission from the publisher." Access to any such CD, DVD, Flash Drive or Web page must be restricted to your organization's employees only.

FOR CME COURSE and SCIENTIFIC SOCIETY MEETINGS:

Permission is restricted to the particular Course, Seminar, Conference, or Meeting indicated in your request. If this license covers a text excerpt or a Full Text Article, access to the reprinted AAAS material must be restricted to attendees of your event only (if you have been granted electronic rights for use of a full text article on your website, your website must be password protected, or access restricted so that only attendees can access the content on your site).

If you are using AAAS Material on a CD, DVD, Flash Drive, or the World Wide Web, you must include the following notice in any electronic versions, either adjacent to the reprinted AAAS material or in the terms and conditions for use of your electronic products: "Readers may view, browse, and/or download material for temporary copying purposes only, provided these uses are for noncommercial personal purposes. Except as provided by law, this material may not be further reproduced, distributed, transmitted, modified, adapted, performed, displayed, published, or sold in whole or in part, without prior written permission from the publisher."

FOR POLICY REPORTS:

These rights are granted only to non-profit organizations and/or government agencies. Permission covers print and electronic versions of a report, provided the required credit line appears in both versions and provided the AAAS material reproduced as permitted herein remains in situ and is not exploited separately.

FOR CLASSROOM PHOTOCOPIES:

Permission covers distribution in print copy format only. Article copies must be freestanding and not part of a course pack. They may not be physically attached to anything or have anything attached to them.

FOR COURSEPACKS OR COURSE WEBSITES:

These rights cover use of the AAAS material in one class at one institution. Permission is valid only for a single semester after which the AAAS material must be removed from the Electronic Course website, unless new permission is obtained for an additional semester. If the material is to be distributed online, access must be restricted to students and instructors enrolled in that particular course by some means of password or access control.

FOR WEBSITES:

You must include the following notice in any electronic versions, either adjacent to the reprinted AAAS material or in the terms and conditions for use of your electronic products: "Readers may view, browse, and/or download material for temporary copying purposes only, provided these uses are for noncommercial personal purposes. Except as provided by law, this material may not be further reproduced, distributed, transmitted, modified, adapted, performed, displayed, published, or sold in whole or in part, without prior written permission from the publisher."

Permissions for the use of Full Text articles on third party websites are granted on a case by case basis and only in cases where access to the AAAS Material is restricted by some means of password or access control. Alternately, an E-Print may be purchased through our reprints department (brocheleau@rockwaterinc.com).

REGARDING FULL TEXT ARTICLE USE ON THE WORLD WIDE WEB IF YOU ARE AN 'ORIGINAL AUTHOR' OF A SCIENCE PAPER

If you chose "Original Author" as the Requestor Type, you are warranting that you are one of authors listed on the License Agreement as a "Licensed content author" or that you are acting on that author's behalf to use the Licensed content in a new work that one of the authors listed on the License Agreement as a "Licensed content author" has written.

Original Authors may post the 'Accepted Version' of their full text article on their personal or on their University website and not on any other website. The 'Accepted Version' is the version of the paper accepted for publication by AAAS including changes resulting from peer review but prior to AAAS's copy editing and production (in other words not the AAAS published version).

FOR MOVIES / FILM / TELEVISION:

Permission is granted to use, record, film, photograph, and/or tape the AAAS material in connection with your program/film and in any medium your program/film may be shown or heard, including but not limited to broadcast and cable television, radio, print, world wide web, and videocassette.

The required credit line should run in the program/film's end credits.

FOR MUSEUM EXHIBITIONS:

Permission is granted to use the AAAS material as part of a single exhibition for the duration of that exhibit. Permission for use of the material in promotional materials for the exhibit must be cleared separately with AAAS (please contact us at permissions@aaas.org).

FOR TRANSLATIONS:

Translation rights apply only to the language identified in your request summary above.

The following disclaimer must appear with your translation, on the first page of the article, after the credit line: "This translation is not an official translation by AAAS staff, nor is it endorsed by AAAS as accurate. In crucial matters, please refer to the official English-

language version originally published by AAAS."

FOR USE ON A COVER:

Permission is granted to use the AAAS material on the cover of a journal issue, newsletter issue, book, textbook, or annual report in print and electronic formats provided the AAAS material reproduced as permitted herein remains in situ and is not exploited separately

By using the AAAS Material identified in your request, you agree to abide by all the terms and conditions herein.

Questions about these terms can be directed to the AAAS Permissions department permissions@aaas.org.

Other Terms and Conditions:

v 2

Questions? customercare@copyright.com or +1-855-239-3415 (toll free in the US) or +1-978-646-2777.

Gratis licenses (referencing \$0 in the Total field) are free. Please retain this printable license for your reference. No payment is required.

NATURE PUBLISHING GROUP LICENSE
TERMS AND CONDITIONS

Apr 14, 2015

This is a License Agreement between Victoria Davis ("You") and Nature Publishing Group ("Nature Publishing Group") provided by Copyright Clearance Center ("CCC"). The license consists of your order details, the terms and conditions provided by Nature Publishing Group, and the payment terms and conditions.

All payments must be made in full to CCC. For payment instructions, please see information listed at the bottom of this form.

License Number	3607440252765
License date	Apr 14, 2015
Licensed content publisher	Nature Publishing Group
Licensed content publication	Nature
Licensed content title	DNA sequence motifs for structure-specific recognition and separation of carbon nanotubes
Licensed content author	Xiaomin Tu, Suresh Manohar, Anand Jagota and Ming Zheng
Licensed content date	Jul 9, 2009
Volume number	460
Issue number	7252
Type of Use	reuse in a dissertation / thesis
Requestor type	academic/educational
Format	print and electronic
Portion	figures/tables/illustrations
Number of figures/tables/illustrations	1
High-res required	no
Figures	Figure 2 c
Author of this NPG article	no
Your reference number	68
Title of your thesis / dissertation	Investigation of Dye-Sensitized Solar Cell Performance with Single Chirality Semiconducting Carbon Nanotubes
Expected completion date	Apr 2015
Estimated size (number of pages)	160
Total	0.00 USD
Terms and Conditions	

Terms and Conditions for Permissions

Nature Publishing Group hereby grants you a non-exclusive license to reproduce this material for this purpose, and for no other use, subject to the conditions below:

1. NPG warrants that it has, to the best of its knowledge, the rights to license reuse of this material. However, you should ensure that the material you are requesting is original to Nature Publishing Group and does not carry the copyright of another entity (as credited in the published version). If the credit line on any part of the material you have requested indicates that it was reprinted or adapted by NPG with permission from another source, then you should also seek permission from that source to reuse the material.
2. Permission granted free of charge for material in print is also usually granted for any electronic version of that work, provided that the material is incidental to the work as a whole and that the electronic version is essentially equivalent to, or substitutes for, the print version. Where print permission has been granted for a fee, separate permission must be obtained for any additional, electronic re-use (unless, as in the case of a full paper, this has already been accounted for during your initial request in the calculation of a print run). NB: In all cases, web-based use of full-text articles must be authorized separately through the 'Use on a Web Site' option when requesting permission.
3. Permission granted for a first edition does not apply to second and subsequent editions and for editions in other languages (except for signatories to the STM Permissions Guidelines, or where the first edition permission was granted for free).
4. Nature Publishing Group's permission must be acknowledged next to the figure, table or abstract in print. In electronic form, this acknowledgement must be visible at the same time as the figure/table/abstract, and must be hyperlinked to the journal's homepage.
5. The credit line should read:
Reprinted by permission from Macmillan Publishers Ltd: [JOURNAL NAME]
(reference citation), copyright (year of publication)
For AOP papers, the credit line should read:
Reprinted by permission from Macmillan Publishers Ltd: [JOURNAL NAME],
advance online publication, day month year (doi: 10.1038/sj.[JOURNAL
ACRONYM].XXXXX)

Note: For republication from the *British Journal of Cancer*, the following credit lines apply.

Reprinted by permission from Macmillan Publishers Ltd on behalf of Cancer Research UK: [JOURNAL NAME] (reference citation), copyright (year of

publication)For AOP papers, the credit line should read:
Reprinted by permission from Macmillan Publishers Ltd on behalf of Cancer
Research UK: [JOURNAL NAME], advance online publication, day month year
(doi: 10.1038/sj.[JOURNAL ACRONYM].XXXXX)

6. Adaptations of single figures do not require NPG approval. However, the adaptation should be credited as follows:

Adapted by permission from Macmillan Publishers Ltd: [JOURNAL NAME]
(reference citation), copyright (year of publication)

Note: For adaptation from the *British Journal of Cancer*, the following credit line applies.

Adapted by permission from Macmillan Publishers Ltd on behalf of Cancer
Research UK: [JOURNAL NAME] (reference citation), copyright (year of
publication)

7. Translations of 401 words up to a whole article require NPG approval. Please visit <http://www.macmillanmedicalcommunications.com> for more information. Translations of up to a 400 words do not require NPG approval. The translation should be credited as follows:

Translated by permission from Macmillan Publishers Ltd: [JOURNAL NAME]
(reference citation), copyright (year of publication).

Note: For translation from the *British Journal of Cancer*, the following credit line applies.

Translated by permission from Macmillan Publishers Ltd on behalf of Cancer
Research UK: [JOURNAL NAME] (reference citation), copyright (year of
publication)

We are certain that all parties will benefit from this agreement and wish you the best in the use of this material. Thank you.

Special Terms:

v1.1

Questions? customercare@copyright.com or +1-855-239-3415 (toll free in the US) or +1-978-646-2777.

Gratis licenses (referencing \$0 in the Total field) are free. Please retain this printable license for your reference. No payment is required.

THE AMERICAN ASSOCIATION FOR THE ADVANCEMENT OF SCIENCE
LICENSE
TERMS AND CONDITIONS
Apr 14, 2015

This is a License Agreement between Victoria Davis ("You") and The American Association for the Advancement of Science ("The American Association for the Advancement of Science") provided by Copyright Clearance Center ("CCC"). The license consists of your order details, the terms and conditions provided by The American Association for the Advancement of Science, and the payment terms and conditions.

All payments must be made in full to CCC. For payment instructions, please see information listed at the bottom of this form.

License Number	3607440554071
License date	Apr 14, 2015
Licensed content publisher	The American Association for the Advancement of Science
Licensed content publication	Science
Licensed content title	Structure-Assigned Optical Spectra of Single-Walled Carbon Nanotubes
Licensed content author	Sergei M. Bachilo, Michael S. Strano, Carter Kittrell, Robert H. Hauge, Richard E. Smalley, R. Bruce Weisman
Licensed content date	Dec 20, 2002
Volume number	298
Issue number	5602
Type of Use	Thesis / Dissertation
Requestor type	Scientist/individual at a research institution
Format	Print and electronic
Portion	Figure
Number of figures/tables	2
Order reference number	55
Title of your thesis / dissertation	Investigation of Dye-Sensitized Solar Cell Performance with Single Chirality Semiconducting Carbon Nanotubes
Expected completion date	Apr 2015
Estimated size(pages)	160
Total	0.00 USD

Terms and Conditions

American Association for the Advancement of Science TERMS AND CONDITIONS

Regarding your request, we are pleased to grant you non-exclusive, non-transferable permission, to republish the AAAS material identified above in your work identified above, subject to the terms and conditions herein. We must be contacted for permission for any uses other than those specifically identified in your request above.

The following credit line must be printed along with the AAAS material: "From [Full Reference Citation]. Reprinted with permission from AAAS."

All required credit lines and notices must be visible any time a user accesses any part of the AAAS material and must appear on any printed copies and authorized user might make.

This permission does not apply to figures / photos / artwork or any other content or materials included in your work that are credited to non-AAAS sources. If the requested material is sourced to or references non-AAAS sources, you must obtain authorization from that source as well before using that material. You agree to hold harmless and indemnify AAAS against any claims arising from your use of any content in your work that is credited to non-AAAS sources.

If the AAAS material covered by this permission was published in Science during the years 1974 - 1994, you must also obtain permission from the author, who may grant or withhold permission, and who may or may not charge a fee if permission is granted. See original article for author's address. This condition does not apply to news articles.

The AAAS material may not be modified or altered except that figures and tables may be modified with permission from the author. Author permission for any such changes must be secured prior to your use.

Whenever possible, we ask that electronic uses of the AAAS material permitted herein include a hyperlink to the original work on AAAS's website (hyperlink may be embedded in the reference citation).

AAAS material reproduced in your work identified herein must not account for more than 30% of the total contents of that work.

AAAS must publish the full paper prior to use of any text.

AAAS material must not imply any endorsement by the American Association for the Advancement of Science.

This permission is not valid for the use of the AAAS and/or Science logos.

AAAS makes no representations or warranties as to the accuracy of any information contained in the AAAS material covered by this permission, including any warranties of merchantability or fitness for a particular purpose.

If permission fees for this use are waived, please note that AAAS reserves the right to charge for reproduction of this material in the future.

Permission is not valid unless payment is received within sixty (60) days of the issuance of this permission. If payment is not received within this time period then all rights granted herein shall be revoked and this permission will be considered null and void.

In the event of breach of any of the terms and conditions herein or any of CCC's Billing and Payment terms and conditions, all rights granted herein shall be revoked and this permission will be considered null and void.

AAAS reserves the right to terminate this permission and all rights granted herein at its discretion, for any purpose, at any time. In the event that AAAS elects to terminate this permission, you will have no further right to publish, publicly perform, publicly display, distribute or otherwise use any matter in which the AAAS content had been included, and all fees paid hereunder shall be fully refunded to you. Notification of termination will be sent to the contact information as supplied by you during the request process and termination shall be immediate upon sending the notice. Neither AAAS nor CCC shall be liable for any costs, expenses, or damages you may incur as a result of the termination of this permission, beyond the refund noted above.

This Permission may not be amended except by written document signed by both parties.

The terms above are applicable to all permissions granted for the use of AAAS material. Below you will find additional conditions that apply to your particular type of use.

FOR A THESIS OR DISSERTATION

If you are using figure(s)/table(s), permission is granted for use in print and electronic versions of your dissertation or thesis. A full text article may be used in print versions only of a dissertation or thesis.

Permission covers the distribution of your dissertation or thesis on demand by ProQuest / UMI, provided the AAAS material covered by this permission remains in situ.

If you are an Original Author on the AAAS article being reproduced, please refer to your License to Publish for rules on reproducing your paper in a dissertation or thesis.

FOR JOURNALS:

Permission covers both print and electronic versions of your journal article, however the AAAS material may not be used in any manner other than within the context of your article.

FOR BOOKS/TEXTBOOKS:

If this license is to reuse figures/tables, then permission is granted for non-exclusive world rights in all languages in both print and electronic formats (electronic formats are defined below).

If this license is to reuse a text excerpt or a full text article, then permission is granted for non-exclusive world rights in English only. You have the option of securing either print or electronic rights or both, but electronic rights are not automatically granted and do garner additional fees. Permission for translations of text excerpts or full text articles into other languages must be obtained separately.

Licenses granted for use of AAAS material in electronic format books/textbooks are valid only in cases where the electronic version is equivalent to or substitutes for the print version of the book/textbook. The AAAS material reproduced as permitted herein must remain in situ and must not be exploited separately (for example, if permission covers the use of a full text article, the article may not be offered for access or for purchase as a stand-alone unit), except in the case of permitted textbook companions as noted below.

You must include the following notice in any electronic versions, either adjacent to the reprinted AAAS material or in the terms and conditions for use of your electronic products: "Readers may view, browse, and/or download material for temporary copying purposes only, provided these uses are for noncommercial personal purposes. Except as provided by law, this material may not be further reproduced, distributed, transmitted, modified, adapted, performed, displayed, published, or sold in whole or in part, without prior written permission from the publisher."

If your book is an academic textbook, permission covers the following companions to your textbook, provided such companions are distributed only in conjunction with your textbook at no additional cost to the user:

- Password-protected website
- Instructor's image CD/DVD and/or PowerPoint resource
- Student CD/DVD

All companions must contain instructions to users that the AAAS material may be used for non-commercial, classroom purposes only. Any other uses require the prior written permission from AAAS.

If your license is for the use of AAAS Figures/Tables, then the electronic rights granted herein permit use of the Licensed Material in any Custom Databases that you distribute the electronic versions of your textbook through, so long as the Licensed Material remains within the context of a chapter of the title identified in your request and cannot be downloaded by a user as an independent image file.

Rights also extend to copies/files of your Work (as described above) that you are required to provide for use by the visually and/or print disabled in compliance with state and federal laws.

This permission only covers a single edition of your work as identified in your request.

FOR NEWSLETTERS:

Permission covers print and/or electronic versions, provided the AAAS material reproduced as permitted herein remains in situ and is not exploited separately (for example, if permission covers the use of a full text article, the article may not be offered for access or for purchase as a stand-alone unit)

FOR ANNUAL REPORTS:

Permission covers print and electronic versions provided the AAAS material reproduced as permitted herein remains in situ and is not exploited separately (for example, if permission covers the use of a full text article, the article may not be offered for access or for purchase as a stand-alone unit)

FOR PROMOTIONAL/MARKETING USES:

Permission covers the use of AAAS material in promotional or marketing pieces such as information packets, media kits, product slide kits, brochures, or flyers limited to a single print run. The AAAS Material may not be used in any manner which implies endorsement or promotion by the American Association for the Advancement of Science (AAAS) or Science of any product or service. AAAS does not permit the reproduction of its name, logo or text on promotional literature.

If permission to use a full text article is permitted, The Science article covered by this permission must not be altered in any way. No additional printing may be set onto an article copy other than the copyright credit line required above. Any alterations must be approved in advance and in writing by AAAS. This includes, but is not limited to, the placement of sponsorship identifiers, trademarks, logos, rubber stamping or self-adhesive stickers onto the article copies.

Additionally, article copies must be a freestanding part of any information package (i.e. media kit) into which they are inserted. They may not be physically attached to anything, such as an advertising insert, or have anything attached to them, such as a sample product. Article copies must be easily removable from any kits or informational packages in which they are used. The only exception is that article copies may be inserted into three-ring binders.

FOR CORPORATE INTERNAL USE:

The AAAS material covered by this permission may not be altered in any way. No additional printing may be set onto an article copy other than the required credit line. Any alterations must be approved in advance and in writing by AAAS. This includes, but is not limited to the placement of sponsorship identifiers, trademarks, logos, rubber stamping or self-adhesive stickers onto article copies.

If you are making article copies, copies are restricted to the number indicated in your request and must be distributed only to internal employees for internal use.

If you are using AAAS Material in Presentation Slides, the required credit line must be

visible on the slide where the AAAS material will be reprinted

If you are using AAAS Material on a CD, DVD, Flash Drive, or the World Wide Web, you must include the following notice in any electronic versions, either adjacent to the reprinted AAAS material or in the terms and conditions for use of your electronic products: "Readers may view, browse, and/or download material for temporary copying purposes only, provided these uses are for noncommercial personal purposes. Except as provided by law, this material may not be further reproduced, distributed, transmitted, modified, adapted, performed, displayed, published, or sold in whole or in part, without prior written permission from the publisher." Access to any such CD, DVD, Flash Drive or Web page must be restricted to your organization's employees only.

FOR CME COURSE and SCIENTIFIC SOCIETY MEETINGS:

Permission is restricted to the particular Course, Seminar, Conference, or Meeting indicated in your request. If this license covers a text excerpt or a Full Text Article, access to the reprinted AAAS material must be restricted to attendees of your event only (if you have been granted electronic rights for use of a full text article on your website, your website must be password protected, or access restricted so that only attendees can access the content on your site).

If you are using AAAS Material on a CD, DVD, Flash Drive, or the World Wide Web, you must include the following notice in any electronic versions, either adjacent to the reprinted AAAS material or in the terms and conditions for use of your electronic products: "Readers may view, browse, and/or download material for temporary copying purposes only, provided these uses are for noncommercial personal purposes. Except as provided by law, this material may not be further reproduced, distributed, transmitted, modified, adapted, performed, displayed, published, or sold in whole or in part, without prior written permission from the publisher."

FOR POLICY REPORTS:

These rights are granted only to non-profit organizations and/or government agencies. Permission covers print and electronic versions of a report, provided the required credit line appears in both versions and provided the AAAS material reproduced as permitted herein remains in situ and is not exploited separately.

FOR CLASSROOM PHOTOCOPIES:

Permission covers distribution in print copy format only. Article copies must be freestanding and not part of a course pack. They may not be physically attached to anything or have anything attached to them.

FOR COURSEPACKS OR COURSE WEBSITES:

These rights cover use of the AAAS material in one class at one institution. Permission is valid only for a single semester after which the AAAS material must be removed from the Electronic Course website, unless new permission is obtained for an additional semester. If the material is to be distributed online, access must be restricted to students and instructors

enrolled in that particular course by some means of password or access control.

FOR WEBSITES:

You must include the following notice in any electronic versions, either adjacent to the reprinted AAAS material or in the terms and conditions for use of your electronic products: "Readers may view, browse, and/or download material for temporary copying purposes only, provided these uses are for noncommercial personal purposes. Except as provided by law, this material may not be further reproduced, distributed, transmitted, modified, adapted, performed, displayed, published, or sold in whole or in part, without prior written permission from the publisher."

Permissions for the use of Full Text articles on third party websites are granted on a case by case basis and only in cases where access to the AAAS Material is restricted by some means of password or access control. Alternately, an E-Print may be purchased through our reprints department (brocheleau@rockwaterinc.com).

REGARDING FULL TEXT ARTICLE USE ON THE WORLD WIDE WEB IF YOU ARE AN 'ORIGINAL AUTHOR' OF A SCIENCE PAPER

If you chose "Original Author" as the Requestor Type, you are warranting that you are one of authors listed on the License Agreement as a "Licensed content author" or that you are acting on that author's behalf to use the Licensed content in a new work that one of the authors listed on the License Agreement as a "Licensed content author" has written.

Original Authors may post the 'Accepted Version' of their full text article on their personal or on their University website and not on any other website. The 'Accepted Version' is the version of the paper accepted for publication by AAAS including changes resulting from peer review but prior to AAAS's copy editing and production (in other words not the AAAS published version).

FOR MOVIES / FILM / TELEVISION:

Permission is granted to use, record, film, photograph, and/or tape the AAAS material in connection with your program/film and in any medium your program/film may be shown or heard, including but not limited to broadcast and cable television, radio, print, world wide web, and videocassette.

The required credit line should run in the program/film's end credits.

FOR MUSEUM EXHIBITIONS:

Permission is granted to use the AAAS material as part of a single exhibition for the duration of that exhibit. Permission for use of the material in promotional materials for the exhibit must be cleared separately with AAAS (please contact us at permissions@aaas.org).

FOR TRANSLATIONS:

Translation rights apply only to the language identified in your request summary above.

The following disclaimer must appear with your translation, on the first page of the article, after the credit line: "This translation is not an official translation by AAAS staff, nor is it endorsed by AAAS as accurate. In crucial matters, please refer to the official English-language version originally published by AAAS."

FOR USE ON A COVER:

Permission is granted to use the AAAS material on the cover of a journal issue, newsletter issue, book, textbook, or annual report in print and electronic formats provided the AAAS material reproduced as permitted herein remains in situ and is not exploited separately

By using the AAAS Material identified in your request, you agree to abide by all the terms and conditions herein.

Questions about these terms can be directed to the AAAS Permissions department permissions@aaas.org.

Other Terms and Conditions:

v 2

Questions? customercare@copyright.com or +1-855-239-3415 (toll free in the US) or +1-978-646-2777.

Gratis licenses (referencing \$0 in the Total field) are free. Please retain this printable license for your reference. No payment is required.

SPRINGER LICENSE
TERMS AND CONDITIONS

Apr 14, 2015

This is a License Agreement between Victoria Davis ("You") and Springer ("Springer") provided by Copyright Clearance Center ("CCC"). The license consists of your order details, the terms and conditions provided by Springer, and the payment terms and conditions.

All payments must be made in full to CCC. For payment instructions, please see information listed at the bottom of this form.

License Number	3607441287830
License date	Apr 14, 2015
Licensed content publisher	Springer
Licensed content publication	Catalysis Letters
Licensed content title	Photocatalytic Properties of TiO ₂ Modified with Gold Nanoparticles in the Degradation of 4-Chlorophenol in Aqueous Solution
Licensed content author	Alexander Orlov
Licensed content date	Jan 1, 2004
Volume number	92
Issue number	1
Type of Use	Thesis/Dissertation
Portion	Figures
Author of this Springer article	No
Order reference number	147
Original figure numbers	Figure 1b
Title of your thesis / dissertation	Investigation of Dye-Sensitized Solar Cell Performance with Single Chirality Semiconducting Carbon Nanotubes
Expected completion date	Apr 2015
Estimated size(pages)	160
Total	0.00 USD
Terms and Conditions	

Introduction

The publisher for this copyrighted material is Springer Science + Business Media. By clicking "accept" in connection with completing this licensing transaction, you agree that the following terms and conditions apply to this transaction (along with the Billing and Payment terms and conditions established by Copyright Clearance Center, Inc. ("CCC"), at the time that you opened your Rightslink account and that are available at any time at <http://myaccount.copyright.com>).

Limited License

With reference to your request to reprint in your thesis material on which Springer Science and Business Media control the copyright, permission is granted, free of charge, for the use indicated in your enquiry.

Licenses are for one-time use only with a maximum distribution equal to the number that you identified in the licensing process.

This License includes use in an electronic form, provided its password protected or on the university's intranet or repository, including UMI (according to the definition at the Sherpa website: <http://www.sherpa.ac.uk/romeo/>). For any other electronic use, please contact Springer at (permissions.dordrecht@springer.com or permissions.heidelberg@springer.com).

The material can only be used for the purpose of defending your thesis limited to university-use only. If the thesis is going to be published, permission needs to be re-obtained (selecting "book/textbook" as the type of use).

Although Springer holds copyright to the material and is entitled to negotiate on rights, this license is only valid, subject to a courtesy information to the author (address is given with the article/chapter) and provided it concerns original material which does not carry references to other sources (if material in question appears with credit to another source, authorization from that source is required as well).

Permission free of charge on this occasion does not prejudice any rights we might have to charge for reproduction of our copyrighted material in the future.

Altering/Modifying Material: Not Permitted

You may not alter or modify the material in any manner. Abbreviations, additions, deletions and/or any other alterations shall be made only with prior written authorization of the author(s) and/or Springer Science + Business Media. (Please contact Springer at (permissions.dordrecht@springer.com or permissions.heidelberg@springer.com))

Reservation of Rights

Springer Science + Business Media reserves all rights not specifically granted in the combination of (i) the license details provided by you and accepted in the course of this licensing transaction, (ii) these terms and conditions and (iii) CCC's Billing and Payment

terms and conditions.

Copyright Notice:Disclaimer

You must include the following copyright and permission notice in connection with any reproduction of the licensed material: "Springer and the original publisher /journal title, volume, year of publication, page, chapter/article title, name(s) of author(s), figure number(s), original copyright notice) is given to the publication in which the material was originally published, by adding; with kind permission from Springer Science and Business Media"

Warranties: None

Example 1: Springer Science + Business Media makes no representations or warranties with respect to the licensed material.

Example 2: Springer Science + Business Media makes no representations or warranties with respect to the licensed material and adopts on its own behalf the limitations and disclaimers established by CCC on its behalf in its Billing and Payment terms and conditions for this licensing transaction.

Indemnity

You hereby indemnify and agree to hold harmless Springer Science + Business Media and CCC, and their respective officers, directors, employees and agents, from and against any and all claims arising out of your use of the licensed material other than as specifically authorized pursuant to this license.

No Transfer of License

This license is personal to you and may not be sublicensed, assigned, or transferred by you to any other person without Springer Science + Business Media's written permission.

No Amendment Except in Writing

This license may not be amended except in a writing signed by both parties (or, in the case of Springer Science + Business Media, by CCC on Springer Science + Business Media's behalf).

Objection to Contrary Terms

Springer Science + Business Media hereby objects to any terms contained in any purchase order, acknowledgment, check endorsement or other writing prepared by you, which terms are inconsistent with these terms and conditions or CCC's Billing and Payment terms and conditions. These terms and conditions, together with CCC's Billing and Payment terms and conditions (which are incorporated herein), comprise the entire agreement between you and Springer Science + Business Media (and CCC) concerning this licensing transaction. In the event of any conflict between your obligations established by these terms and conditions and those established by CCC's Billing and Payment terms and conditions, these terms and conditions shall control.

Jurisdiction

All disputes that may arise in connection with this present License, or the breach thereof, shall be settled exclusively by arbitration, to be held in The Netherlands, in accordance with Dutch law, and to be conducted under the Rules of the 'Netherlands Arbitrage Instituut' (Netherlands Institute of Arbitration). **OR:**

All disputes that may arise in connection with this present License, or the breach thereof, shall be settled exclusively by arbitration, to be held in the Federal Republic of Germany, in accordance with German law.

Other terms and conditions:

v1.3

Questions? customercare@copyright.com or +1-855-239-3415 (toll free in the US) or +1-978-646-2777.

Gratis licenses (referencing \$0 in the Total field) are free. Please retain this printable license for your reference. No payment is required.
